



Front Rollout Egg Gathering System

Installation and Operation Manual

PNEG-907

Date: 10-07-10



PNEG-907

Contents

Chapter 1 Safety	4
Safety Guidelines	4
General Safety Statement	5
Safety Sign-Off Sheet	8
Chapter 2 Safety Decals	9
Chapter 3 Egg Gathering System	12
Mechanical Egg Gathering System Specifications	12
Cumberland Egg Gathering System Management Guide	13
Chapter 4 Installation Instructions	14
FRN Front Rollout Nest Assembly Instructions	16
AN199 Egg Collector Assembly Instructions	31
Return Idler Assembly	34
Aisle Tray Assembly	34
Egg Belt Installation	35
Egg Belt Adjustment	37
Diverter Installation	38
Electrical Installation for AN199 Egg Collector	38
Chapter 5 Wiring Diagrams	39
AN199 Egg Collector - 115 Volt 1 Phase Wiring Diagram	39
AN199 Egg Collector - 220 Volt 1 Phase Wiring Diagram	39
AN199 Egg Collector - 220 Volt 3 Phase Wiring Diagram	40
AN199 Egg Collector - 380 Volt and 415 Volt 3 Phase Wiring Diagram	40
Chapter 6 Maintenance	41
Egg Belt Care	42
Operating the Speed Control Assembly	43
Chapter 7 Parts List	44
FRN16, FRN20 Nest Assembly	44
AN199 Egg Collector Assembly	46
Internal Drive Assembly	47
Power Unit Assembly	48
Return Idler Assembly	49
Chapter 8 Warranty	51

Safety Guidelines

This manual contains information that is important for you, the owner/operator, to know and understand. This information relates to protecting **personal safety** and **preventing equipment problems**. It is the responsibility of the owner/operator to inform anyone operating or working in the area of this equipment of these safety guidelines. To help you recognize this information, we use the symbols that are defined below. Please read the manual and pay attention to these sections. Failure to read this manual and its safety instructions is a misuse of the equipment and may lead to serious injury or death.



This is the safety alert symbol. It is used to alert you to potential personal injury hazards. Obey all safety messages that follow this symbol to avoid possible injury or death.



DANGER indicates an imminently hazardous situation which, if not avoided, will result in death or serious injury.



WARNING indicates a potentially hazardous situation which, if not avoided, could result in death or serious injury.



CAUTION indicates a potentially hazardous situation which, if not avoided, may result in minor or moderate injury.



CAUTION used without the safety alert symbol indicates a potentially hazardous situation which, if not avoided, may result in property damage.



NOTE indicates information about the equipment that you should pay special attention.



WARNING! BE ALERT!

Personnel operating or working around equipment should read this manual. This manual must be delivered with the equipment to its owner. Failure to read this manual and its safety instructions is a misuse of the equipment.

General Safety Statement

Thank you for choosing a Cumberland Mechanical Egg Collection System. It is designed to give excellent performance and service for many years. Cumberland's principle concern is your safety and the safety of others associated with poultry equipment. We want to keep you as a customer. This manual is to help you understand safe operating procedures and some problems which may be encountered by the operator and other personnel.

As owner and/or operator, you are responsible to know what requirements, hazards and precautions exist and inform all personnel associated with the equipment or in the area. Safety precautions may be required from the personnel. Avoid any alterations to the equipment, which may produce a very dangerous situation, where SERIOUS INJURY or DEATH may occur.

Cumberland recommends that you contact your local power company and have a representative review your installation to verify that all wiring is compatible with their system and ensure an adequate power will be supplied to your unit.

Electrical Safety

An adequate and safe power supply to the Egg Collection System unit is essential for safety. A competent and qualified electrician must undertake all electrical wiring. All wiring is to be installed according to the National Standards and Regulations relevant to your Country and Region.

Cumberland recommends that the electrical supply to the Egg Collection System be provided with a single lockable isolator (not supplied) in accordance with the requirements of IEC 60204-1: 1997. The isolator should meet the requirements of IEC 60947-3. An isolator is essential for safety. This should be installed as indicated in the enclosed wiring diagrams and in accordance with the relevant codes and directives.

Users Manual

This manual contains information and instructions essential to the safe installation and use of the Cumberland Egg Collection System. Read this manual thoroughly **before** attempting any installation or use of the Egg Collection System. Keep this manual with the Egg Collection System or in a location where it can be readily accessed. Failure to read this manual and its safety instructions is a misuse of the equipment.

Structural Safety

Raising and lowering the Egg Collection System in a poultry house imposes additional load on the building. It is essential that the building is able to bear this additional load. Consult a structural engineer to verify the building's load capacity. Likely/estimated weights of the Egg Collection System are provided in this manual.

Correct Use of Your Egg Collection System

Only genuine Cumberland parts are to be used in the installation, maintenance and use of the Egg Collection System. Use of other non-genuine parts is a misuse of the system and may lead to dangerous situations imperilling the safety and health of you and others.

This machine is not designed for use in atmospheres where there is a risk of explosion. Such environments may include enclosed areas of high dust concentrations, gas, vapors and fumes. Use of the Egg Collection System in such an environment is prohibited. If in doubt, contact Cumberland or your dealer.

1. Safety

Safety Guards

The Egg Collection System contains many moving and electrical parts which will cause serious injury or death if touched. Guards are placed on the machine for your protection. Operating the machine at any time with guards removed or incorrectly fitted is a serious misuse of the machine and endangers safety.

Safety in Handling the Egg Collection System

Some components of the Egg Collection System require manual handling during installation. To prevent injury, seek assistance where necessary.

Some items may have sharp, rough or abrasive edges. To prevent injury, use suitable hand protection when manually handling the components of this system.

Safety in Maintenance

While the Egg Collection System is designed to keep maintenance to a minimum, some repairs will be necessary in the course of the life of the machine. Do not attempt any repairs on the machine unless you are competent to do so. Never attempt any work on the Egg Collection System without first isolating the machine from the power and locking the isolator so that only you can turn the power back on.

Take special care when approaching the belt, chain or other driven components as there may be tension stored up in the system which could cause injury when released. Approach these items with care using a suitable tool rather than your hands until it is clear that the tension is released.

Follow all guidelines given in the maintenance section [on Page 41](#).

Before restarting the Egg Collection System, ensure that all electrical enclosures are locked closed and all guards and other safety measures are correctly fitted.

If in any doubt, contact your dealer or Cumberland for assistance.

Noise

Noise is not generally a hazard associated with the Egg Collection System. Excessive noise may indicate a problem with the machines. Tests on this machine indicate noise levels at a position, one meter from the drive unit, 1.6 meters above the ground do not exceed 70 dBa, continuous "A" weighted sound pressure or 63 Pa, instantaneous "C" weighted sound pressure.

Safety Signs and Warnings

The following pages show you exactly where the safety signs, warnings and other decals should be placed on the Egg Collection System. If a decal is missing, damaged or unreadable, please contact your dealer or Cumberland, a member of the GSI Group, for a free replacement.

Installation Notes

To ensure the safety during installation, make all electrical connections as the final step of installation. This should be done only when the Egg Collector has been fully installed and all guards and covers are fixed in place. Electrical connection should be carried out only by a qualified electrical installer and should be to the relevant rules and directives in force in your region.

For guidance or assistance on any issues relating to the safe use of the Egg Collection System,

Contact:

Cumberland

1004 E. Illinois St.
Assumption, IL. 62510
Phone: 1-217-226-4421

Use Caution in the Operation of this Equipment

The design and manufacture of the Egg Collection System is directed toward operator safety. However, the very nature of an Egg Collection System requiring electrical power and possessing moving parts does present a hazard to personnel which cannot be completely safeguarded against without interfering with efficient operation and reasonable access to components.

Continued safe, dependable operation of automatic equipment depends, to a great degree, upon the owner/operator. For a safe and dependable Egg Collection System, follow the recommendations within this manual and make it a practice to regularly inspect the operation of the unit for any developing problems or unsafe conditions.

Take special note of the safety precautions listed before attempting to operate the Egg Collection System.

**READ THESE INSTRUCTIONS BEFORE INSTALLATION, OPERATION AND SERVICE
SAVE FOR FUTURE REFERENCE**

1. Read and understand the operating manual before trying to install or operate the mechanical nest collection system.
2. Power supply should be OFF and LOCKED OUT for service of electrical components. Use CAUTION in checking voltage or other procedures requiring power to be ON.
3. Never attempt to operate the Egg Collection System by jumping or otherwise bypassing any safety devices on the unit.
4. Keep the Egg Collection System clean. Do not allow debris to collect around drive rollers, bearings or return rollers.
5. Use CAUTION in working around the Egg Collection System's moving parts.

This product is intended for the use of egg handling only. Any other use is considered a misuse of the product.

Some edges of the product's components are sharp. Examine each product component to determine if there are any safety considerations to be taken prior to use and/or installation. Any and all necessary personal protective equipment should be worn at all times when handling, assembling, installing and operation of the product and/or its components.

Throughout this manual, guards are removed for illustration purposes only. All guards must be in place before and during operation.

This manual describes the installation and operation for all standard production mechanical Egg Gathering Systems. Safety decals should be read and understood by all people in the Nesting/Egg Handling area. If a decal has been damaged or is missing, contact Cumberland for a free replacement:

Cumberland

1004 E. Illinois St.
Assumption, IL. 62510
Phone: 1-217-226-4421

Decals are identified by the "DC" part number in the bottom right hand corner of all decals.

Decals for the mechanical Egg Gathering System are shown here. The following pages show their location within the Egg Collection System.



DC-889 Danger High Voltage

This decal is located on the outside and the inside of the electrical box, near the two (2) microswitches that are a part of the swing arm mechanism, and inside the speed control assembly. It measures 2-3/4" (7 cm) long x 1-1/2" (3.81 cm) wide.



DC-971 Warning Automatically Controlled

This decal is located on the egg collector above the four (4) side removable doors and on top and under the hood on the return idler assemblies. It measures 3.00" (7.62 cm) long x 5.00" (12.7 cm) wide.

2. Safety Decals

Guards are removed for illustration purpose only. All guards must be in place before/during operation.



Guards are removed for illustration purpose only. All guards must be in place before/during operation.



Mechanical Egg Gathering System Specifications

NOTE: 1" = 2.54 Centimeter

Nest Specifications

Model	Holes/Section	Hole Size	Section Length	Section Width	Section Height	Weight (lbs.)
AN10	10	12" x 13"	60"	34-1/4"	27-1/2"	75
AN12*	12	9-3/4" x 13"	60"	34-1/4"	27-1/2"	80
AND24	24	9-3/4" x 13"	60"	34-1/4"	40-1/2"	120
FRN16	16	11-3/4" x 12-1/4"	96"	34"	24"	125
FRN20	20	9-1/2" x 12-1/4"	96"	34"	24"	130

Material Specifications

Component	Material Specification
Nest, Back and Top Panels, Top Cover, Front Strap	0.018" Galv.
Long and Short Center Endplates	0.049" Galv.
Egg Tray	0.038" Galv.
Aisle Trays (12"-120" Available)	0.049" Galv.
Aisle Tray Covers (AN)	0.085" PVC
Aisle Tray Covers (FRN)	0.085" PVC
Plastic Perch Assembly	Polypropylene

Nest Pad Specifications

Model	Size	Material	Nest Bottom
AN10	13" x 14"	Turf or Rubber	Wire
AN12*	11-3/4" x 13"	Turf or Rubber	Plastic
AND24	11-3/4" x 13"	Turf or Rubber	Plastic
FRN16	9-5/8" x 7-3/4"	Turf or Rubber	Plastic
FRN20	9-1/4" x 5-1/2"	Turf or Rubber	Plastic

Egg Collection Tables - All Variable Speed, Reversible w/ 40:1 Ratio Gearbox

Model	Description	Belt Speed
AN392, AN893, AN392SHT	1/2 HP 90V DC Drive 120V 50/60 Hz Input	0-40 FPM
AN392-3/4, AN893-3/4	3/4 HP 90V DC Drive 120V 50/60 Hz Input	0-40 FPM
AN392-230/1	1/2 HP 90V DC Drive 230V 50/60 Hz Input	0-40 FPM
AND392	DbI Stack 3/4 HP 90V DC Drive 120V 50/60 Hz Input	0-40 FPM
AN199	Front Rollout 1/2 HP 90V DC Drive 120V 50/60 Hz Input	0-40 FPM

* Variations are available; please contact Cumberland for the specific needs.

Egg Collector Specifications

Model	L	W	H*	Table Top Size	Table Top Height
AN392	32-1/2"	13" Front 24" Back	23"	28" x 18"	Adj. 28"-40"
AN893	32-1/2"	13" Front 24" Back	23"	48" x 42"	Adj. 28"-40"
AN392SHT	32-1/2"	13" Front 24" Back	17"	28" x 18"	Adj. 20"-26"
AND392	32-1/2"	13" Front 24" Back	35-1/2"	28" x 18" (2)	Adj. 28"-40" (Lower)
AN199	32-1/2"	13" Front 24" Back	23"	37" x 31"	Adj. 20"-26"

* Height without legs attached.

Cumberland Egg Gathering System Management Guide

Initial Placement of Birds

1. Nests should remain winched when birds are first placed in the breeder house. This will allow easy movement to feed and water.
2. Once birds are accustomed to the house, the nests may be lowered but should remain closed until the first egg is found. This will help to discourage the birds from roosting in the nest.

When First Egg is Found

1. Institute and consistently apply the specific management program.
 - a. Floor and slat eggs need to be picked up a minimum of six (6) times per day until the flock has reached peak. If clutches are found, the house should be checked more often.
 - b. Place all eggs in nest or collect in a basket per integrator preference.
 - c. Be certain NOT to disrupt hens who are utilizing the nest.
2. With continued use of a consistent program, the number of floor and slat eggs should decrease during the production cycle.
3. Close nests out after last collection and reopen while lights are out.

Peak Production

1. Eggs should be collected no less than four (4) times per day.
2. Continue floor and slat egg monitoring procedure.
3. Close nests out after last collection and reopen while lights are out.

NOTES: *Many conditions within the house will affect how well any nest system is going to perform. We encourage you to pay special attention to ventilation, water, feed systems and lighting to achieve maximum results.*

The above recommendations are guidelines only. Different kinds of breeder birds will have specific characteristics that need to be considered when developing a management system. Always follow the instructions of the integrator or controlling body.

4. Installation Instructions

Recommended Nest Placement

The layout of the nest system has been designed to meet the specifications. Refer to [Figure 4A](#), [Figure 4B on Page 15](#) and [Figure 4C on Page 16](#) for placement.

Distance between the first nest and the egg collector is approximately 60" (152 cm). Take this into consideration when placing the first nest.

It is essential that the nest sections are properly aligned and leveled to allow for the free movement of the conveyor belt. The lap and the splice of the belt must be carefully directed to avoid the belt catching on the supporting structure and belt guides.

If nest sections are to be placed in pairs, the splice plates riveted onto the egg trays will extend under the egg trays of the next nest. Secure the nest sections together via the splice plate with two (2) 3/16" steel rivets per egg tray. The connecting winch bracket will extend over the joining nest and is riveted using ten (10) 3/16" steel rivets. Above the back panel of the adjoining nest, bolt the connecting winch bracket together using two (2) 1/4" bolts and nuts. ([See Figure 4B on Page 15.](#))

Aisle trays are used to connect nest sections/pairs. Splice plates and belt guides are supplied with aisle trays. ([See Figure 4C on Page 16.](#))

Installation Notes ([See Figure 4A on Page 15.](#))

Area where nests rest must be level from front to back. Use shims where necessary.

Maintain a minimum of 24" (61 cm) between side of nest and feed trough.

Distance between side of nests and scratch area should be 18" (46 cm) minimum.

Distance between top of slats and floor where collector will be mounted should be a minimum of 30" (76 cm).

Winching

Cumberland cannot be responsible for the capacity of the structure to support the nesting/collection system. For weight load capabilities, contact a structural engineer.

When you are ready to winch the system, be sure to select winches that will support the weight of the system. Each 8' FRN20 nest section weighs approximately 130 pounds (50 kg). Aisle trays/covers weigh approximately 1 pound/foot (1.4 kg/m). The AN199 collector assembly weighs approximately 300 pounds (136 kg) including the return idlers.

A cable drop is required to connect to the winching brackets at the center and each end of each nest; five (5) drops are required when nests are in pairs. The egg belt will have to be cut at the collection table prior to winching unless the collector is also winched. If the egg collector is winched, slots will need to be cut into the wall to allow for the travel of the diverter trays.

Make certain the system is as level as possible when winching.

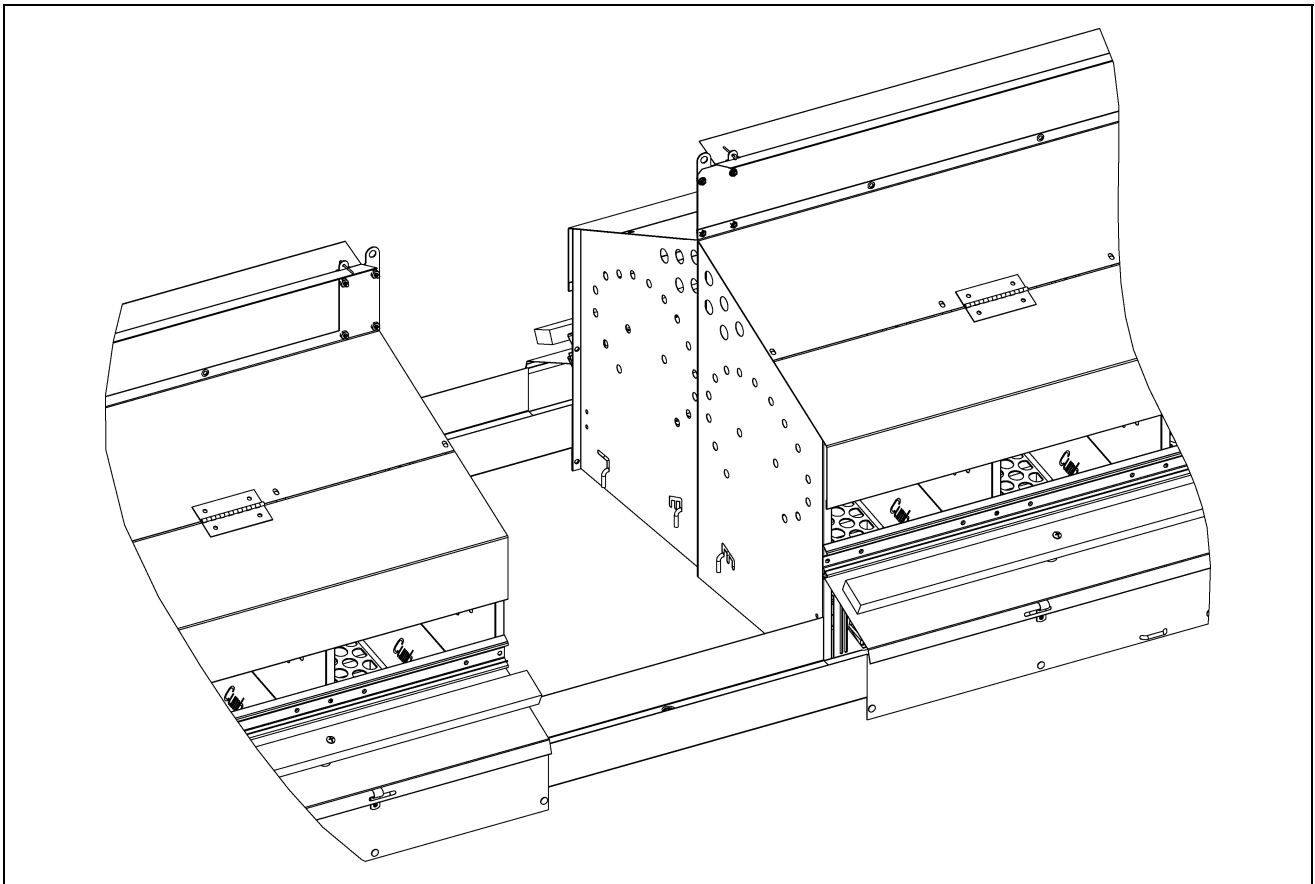

Figure 4C Aisle Tray/Cover Assembly

FRN Front Rollout Nest Assembly Instructions



BE CAREFUL, there are many sharp edges that can cut while assembling the FRN Nest System. Wear protective clothing and gloves.

Tools Required

1. Pneumatic pop rivet gun (3/16" rivets)
2. Phillips and flat head screwdrivers
3. 5/16" Nutdriver
4. Pliers
5. Awl (optional)

Number of Persons Required

For easiest assembly of the FRN nesting system, two (2) people should work together.

NOTE: It is advisable to assemble each nest near its final installation. Be sure to read through each step completely prior to proceeding. Distance between the first nest and the egg collector is approximately 60" (152 cm). Take this into consideration when placing the first nest.

FRN Front Rollout Nest Assembly Instructions (Continued)

Assembly

1. Set back panel upright with chamfered corners up as shown in *Figure 4D*. Assemble a nest panel on **both** sides of back panel, *See Figure 4D*. Use the pneumatic rivet gun and three (3) **S-7222 (3/16" rivet diameter, 5/16" long aluminium rivets) aluminium pop rivets** to secure each **pair** of nest panels to the back panel. Be sure each rivet extends through all material thicknesses before securing.
2. Complete the assembly of all nest panels (eleven (11) sets for FRN20, nine (9) sets for FRN16) to the back panel in this manner.

ATTENTION: Use of S-7060 #64 rivet (longer rivet 7/16" long). To be limited to the following applications.

- a. Plastic blinder to stringer (2 per - 40 total)
- b. Hinge to nest top and swing top (4 per - 24 total)
- c. Tray cover to hinge clamp (1 per - 6 total)

Use of S-7222 #62 rivet (shorter rivet 5/16" long). To be use on all nest connections EXCEPT those listed above.

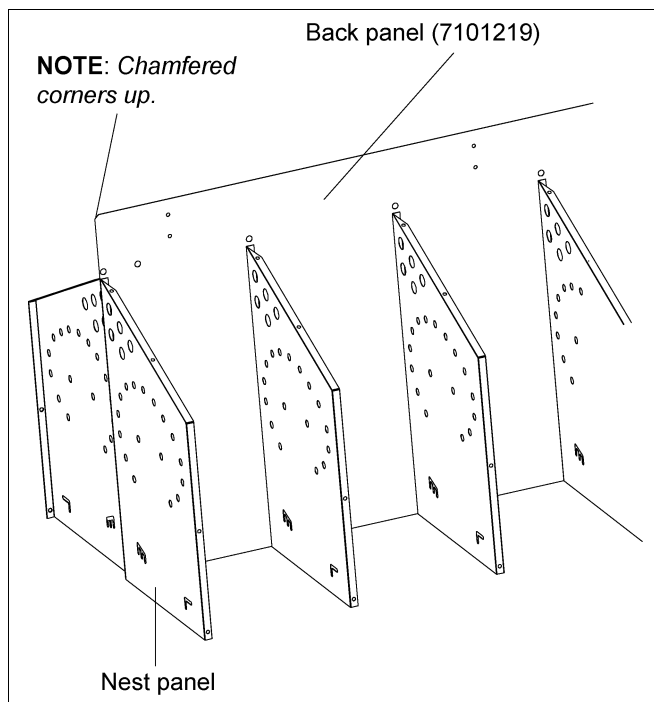

Figure 4D Nest Panel to Back Panel Assembly



Figure 4E

Part #	Description	Qty
7101219	Back Panel (FRN20)	1
C5000206	Nest Panel (FRN20)	22
S-7222	3/16" Rivet Diameter, 5/16" Long Aluminium Rivets	33
C5000028	Back Panel (FRN16)	1
C5000206	Nest Panel (FRN16)	18

FRN Front Rollout Nest Assembly Instructions (Continued)

NOTE: Read this step completely before proceeding.

- Secure the flat edge of the stringer to each nest panel using eleven (11) **S-7222 (3/16" rivet diameter, 5/16" long aluminium rivets) aluminium rivets** (nine (9) for FRN16). Insert the long end of three (3) tray braces between the stringer and the **second, sixth and tenth nest panels for FRN20 (second, fifth and eighth for FRN16)** prior to securing with the rivet. (See Figure 4F.) Complete this step on both sides of the nest.

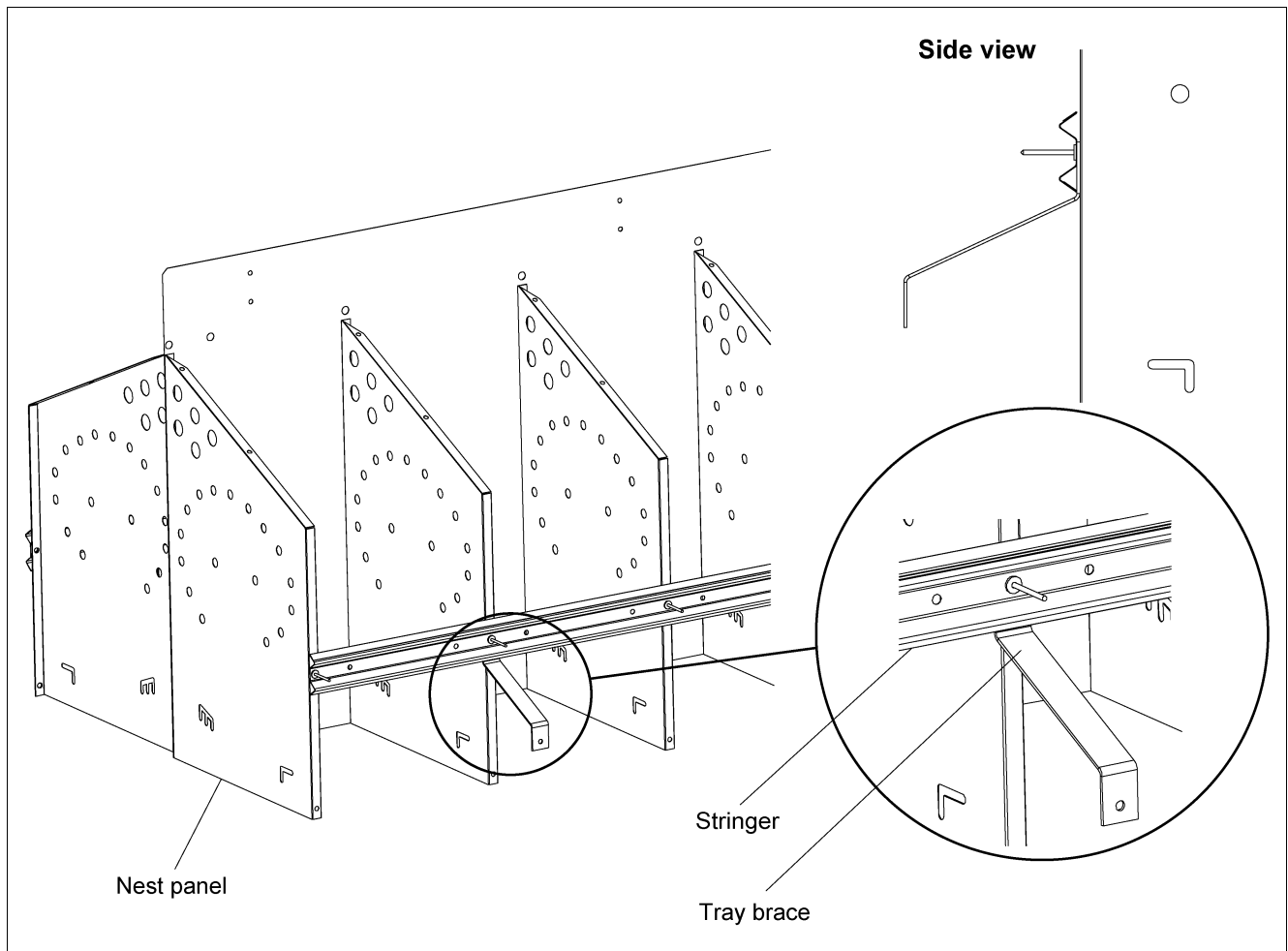

Figure 4F Stringer/Tray Brace Assembly

Part #	Description	Qty
7101218	Stringer (FRN20)	2
7101206	Tray Brace (FRN20)	6
S-7222	3/16" Rivet Diameter, 5/16" Long Aluminium Rivets	22
C5000031	Stringer (FRN16)	2
7101206	Tray Brace (FRN16)	6

FRN Front Rollout Nest Assembly Instructions (Continued)

4. Attach egg tray/front plate assembly to the nest panels using eleven (11) **S-7222 (3/16" rivet diameter, 5/16" long aluminium rivets) aluminium rivets** (nine (9) for FRN16). Secure rivets from under the egg tray on through the nest panel. (See [Figure 4G.](#)) Complete this step on both sides of the nest. **Do not rivet front plate to tray brace at this time.**

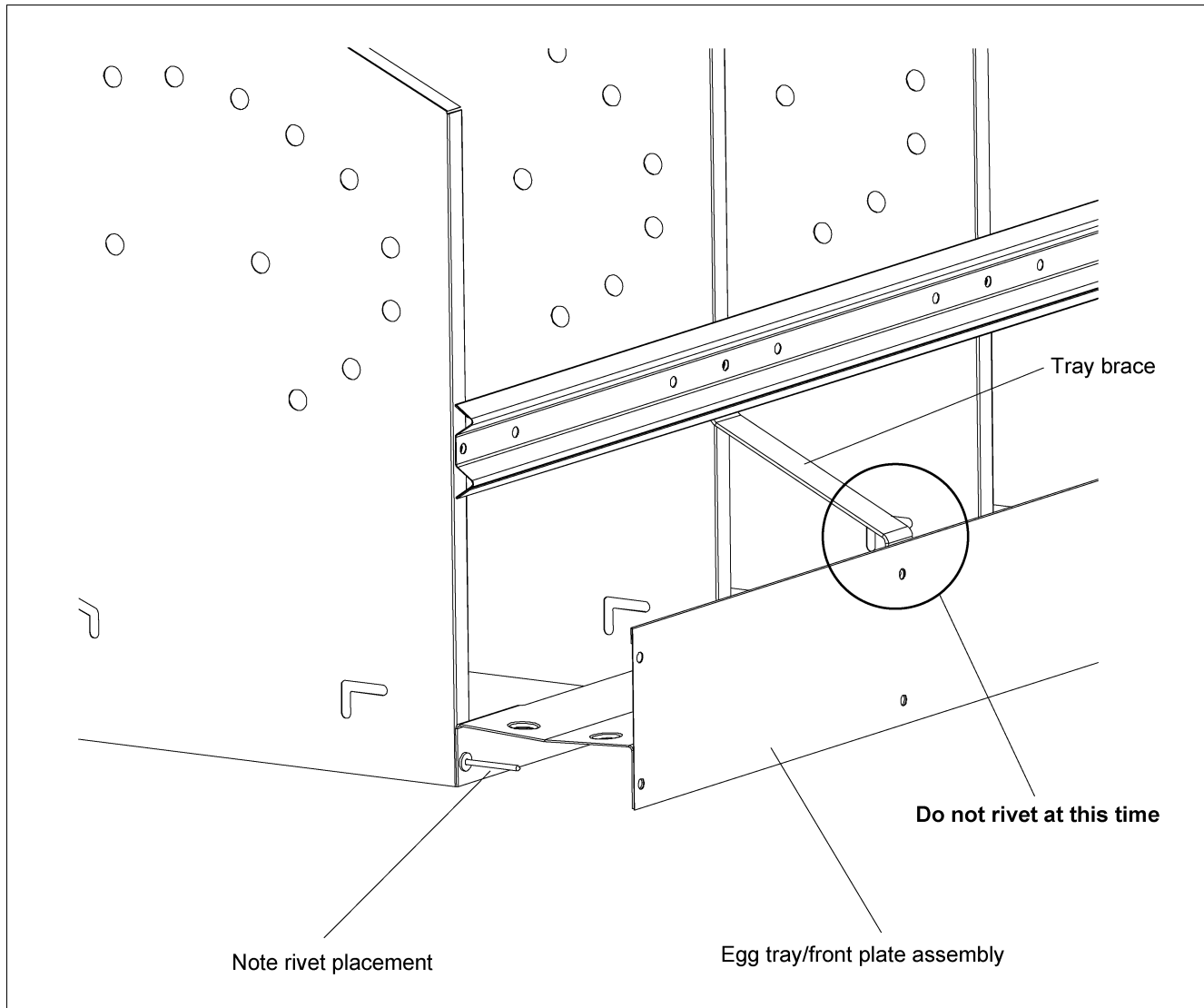

Figure 4G Egg Tray/Front Plate Assembly to Nest

Part #	Description	Qty
C5000102	FRN20 (Egg Tray/Front Plate Assembly)	2
C5000109	FRN16 (Egg Tray/Front Plate Assembly)	2
S-7222	3/16" Rivet Diameter, 5/16" Long Aluminium Rivets	22

FRN Front Rollout Nest Assembly Instructions (Continued)

5. On both sides of nest, secure the nest top to the nest panels using eleven (11) **S-7222 (3/16" rivet diameter, 5/16" long aluminium rivets) aluminium rivets** per side (nine (9) per side for FRN16). Rivet only the bottom row of the nest top as shown. *(See Figure 4H.)*

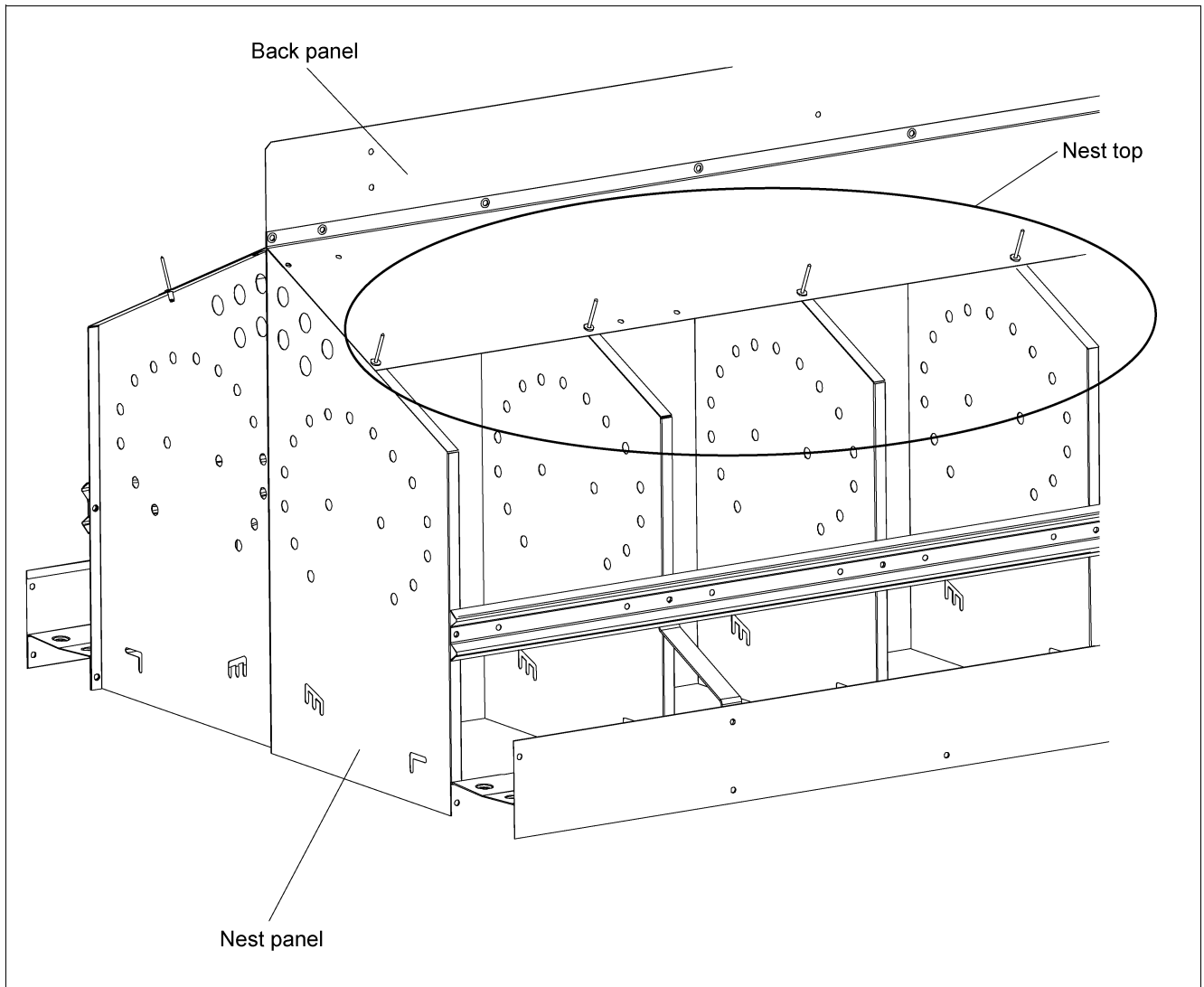

Figure 4H Nest Top Assembly

Part #	Description	Qty
7101217	Nest Top (FRN20)	2
S-7222	3/16" Rivet Diameter, 5/16" Long Aluminium Rivets	22
C5000029	Nest Top (FRN16)	2

FRN Front Rollout Nest Assembly Instructions (Continued)

6. Attach a winch bracket on each end as shown in *Figure 4I*. (See Note.) Use S-7139 #10-24 x 3/8" screws, S-6151 #10 external tooth washers and S-849 #10-24 nuts to attach winch brackets to the nest back panel.

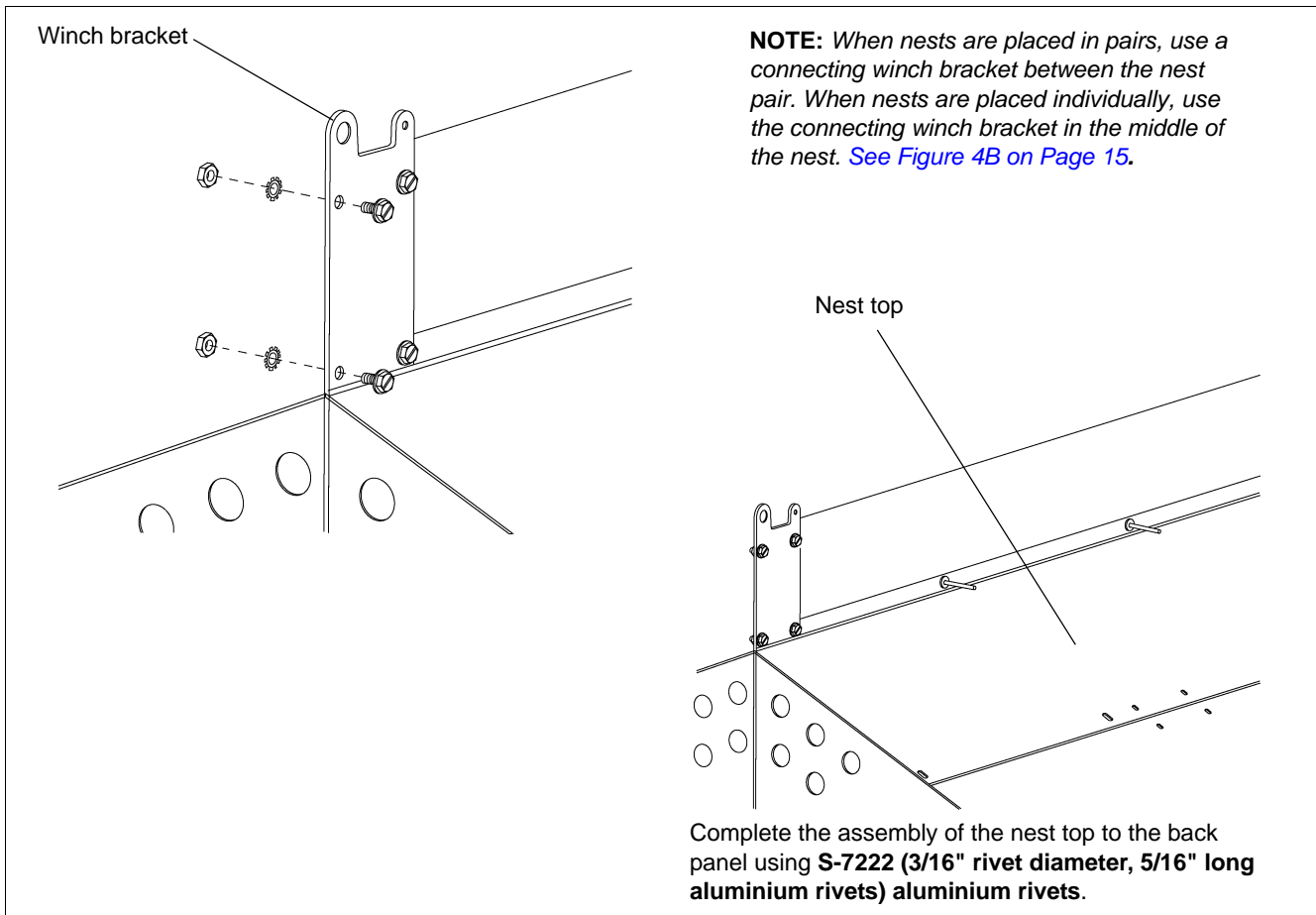

Figure 4I Nest Top/Winch Bracket Assembly

Part #	Description	Qty
C5000103	Winch Bracket (FRN20)	2
C2000107	Connecting Bracket (FRN20)	1
S-7139	#10 Screw (FRN20)	4
S-6151	#10 Washer (FRN20)	4
S-849	#10 Nut (FRN20)	4
C5000103	Winch Bracket (FRN16)	2
C2000107	Connecting Bracket (FRN16)	1
S-7139	#10 Screw (FRN16)	4
S-6151	#10 Washer (FRN16)	4
S-849	#10 Nut (FRN16)	4
S-7222	3/16" Rivet Diameter, 5/16" Long Aluminium Rivets	9

FRN Front Rollout Nest Assembly Instructions (Continued)

7. Secure three (3) hinges per side to nest tops using two (2) **S-7060 (3/16" rivet diameter, 7/16" long aluminium rivets) aluminium rivets** per hinge. Using the same rivets, secure the swing top to the hinge. Note hinge and rivet placement. (See [Figure 4J.](#))

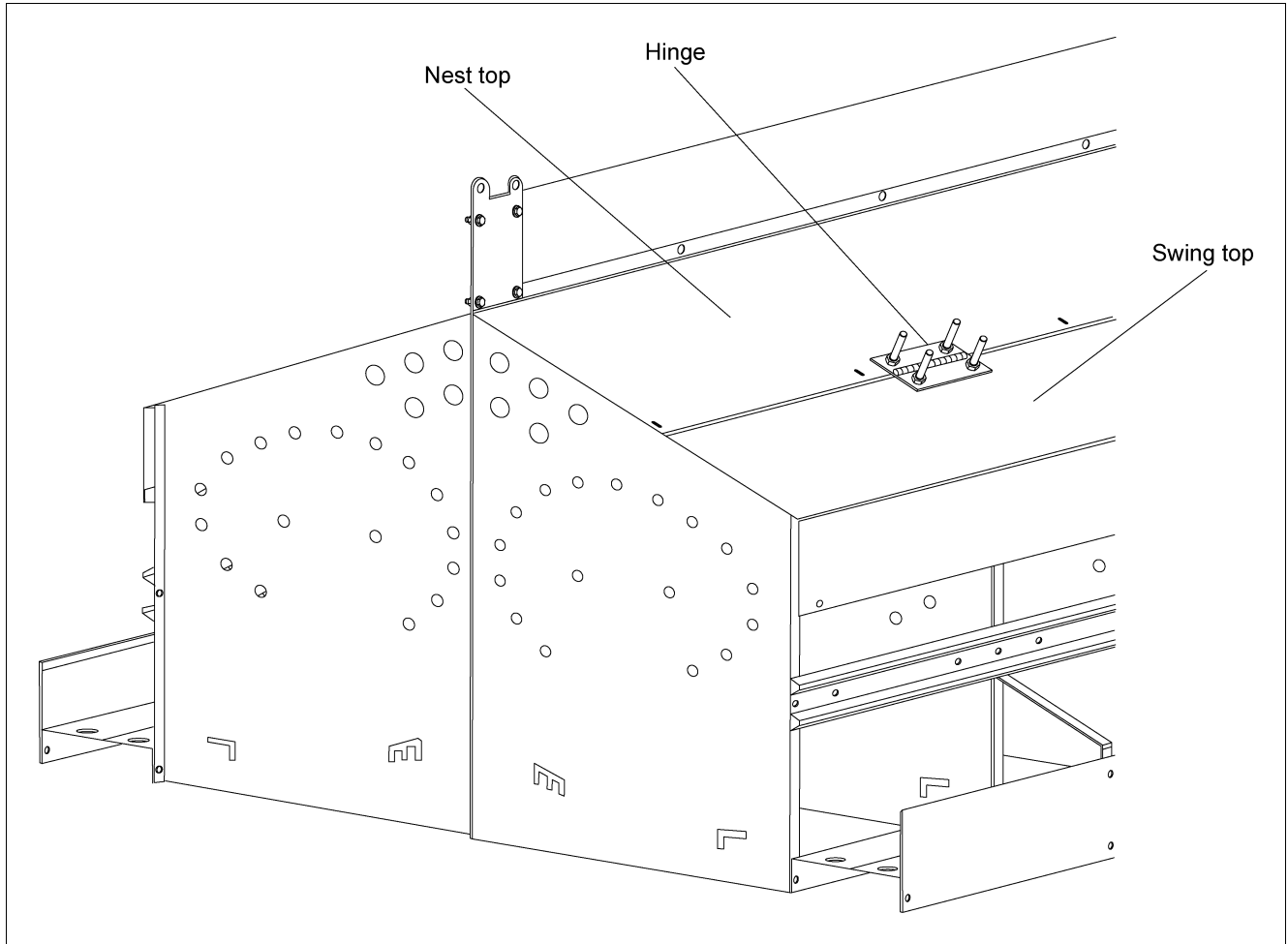

Figure 4J Swing Top Assembly

Part #	Description	Qty
30-0221	Hinge (FRN20)	6
7101214	Swing Top (FRN20)	2
S-7060	3/16" Rivet Diameter, 7/16" Long Aluminium Rivets	24
30-0221	Hinge (FRN16)	6
C5000043	Swing Top (FRN16)	2

FRN Front Rollout Nest Assembly Instructions (Continued)

8. Insert four (4) nest bottom support rods through all nest panels as shown in [Figure 4K](#). “Lock” the rods in position by seating the rods into the desired slot in all nest panels.

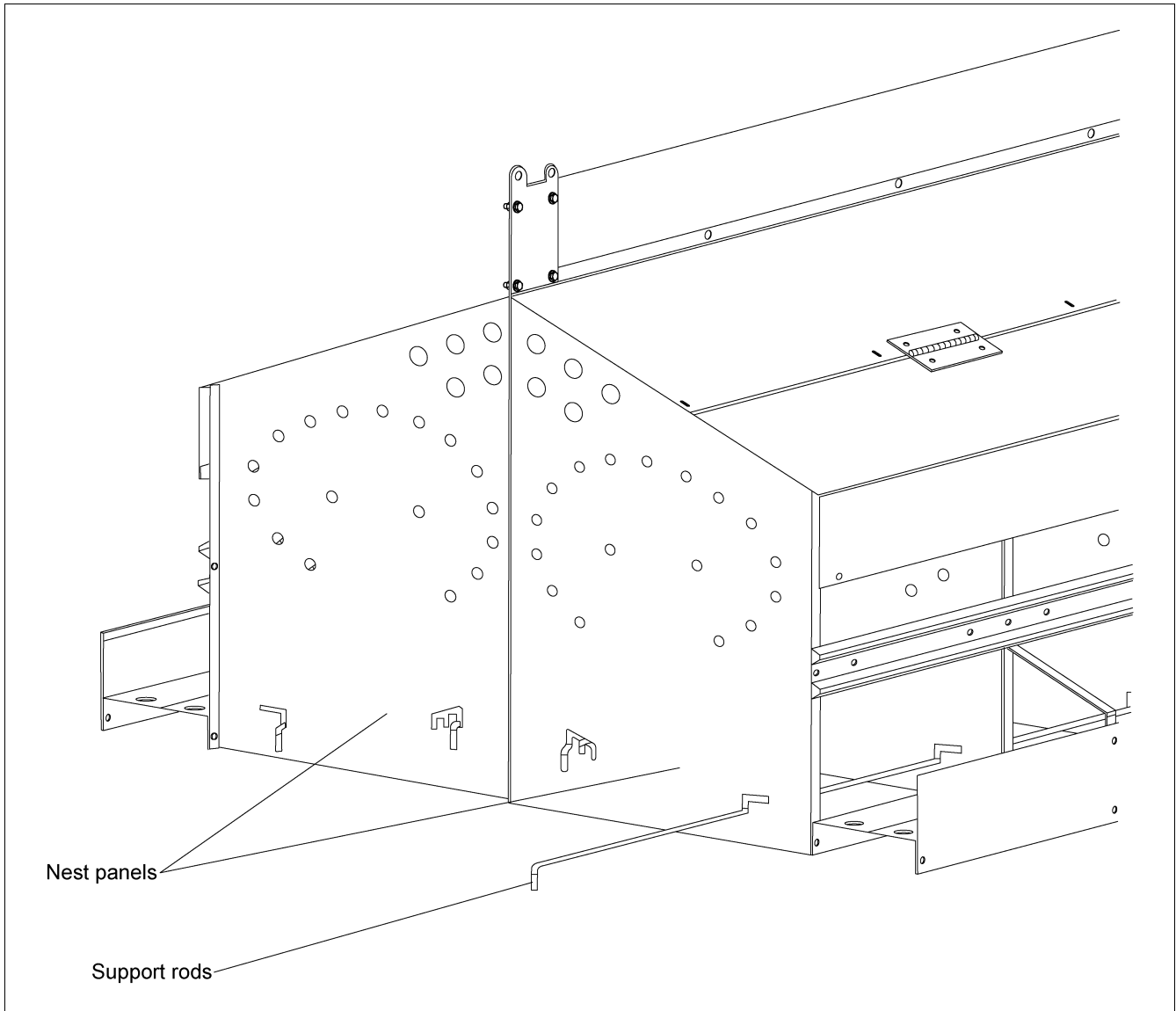

Figure 4K Nest Bottom Support Rod Assembly

Part #	Description	Qty
C5000026	Support Rod (FRN20)	4
C5000026	Support Rod (FRN16)	4

FRN Front Rollout Nest Assembly Instructions (Continued)

9. Assemble hinge clamp to egg tray cover by inserting the clamp through the slots in the egg tray cover. There are three (3) clamps per egg tray cover. Repeat this process for both egg tray covers. (See Figure 4L.)

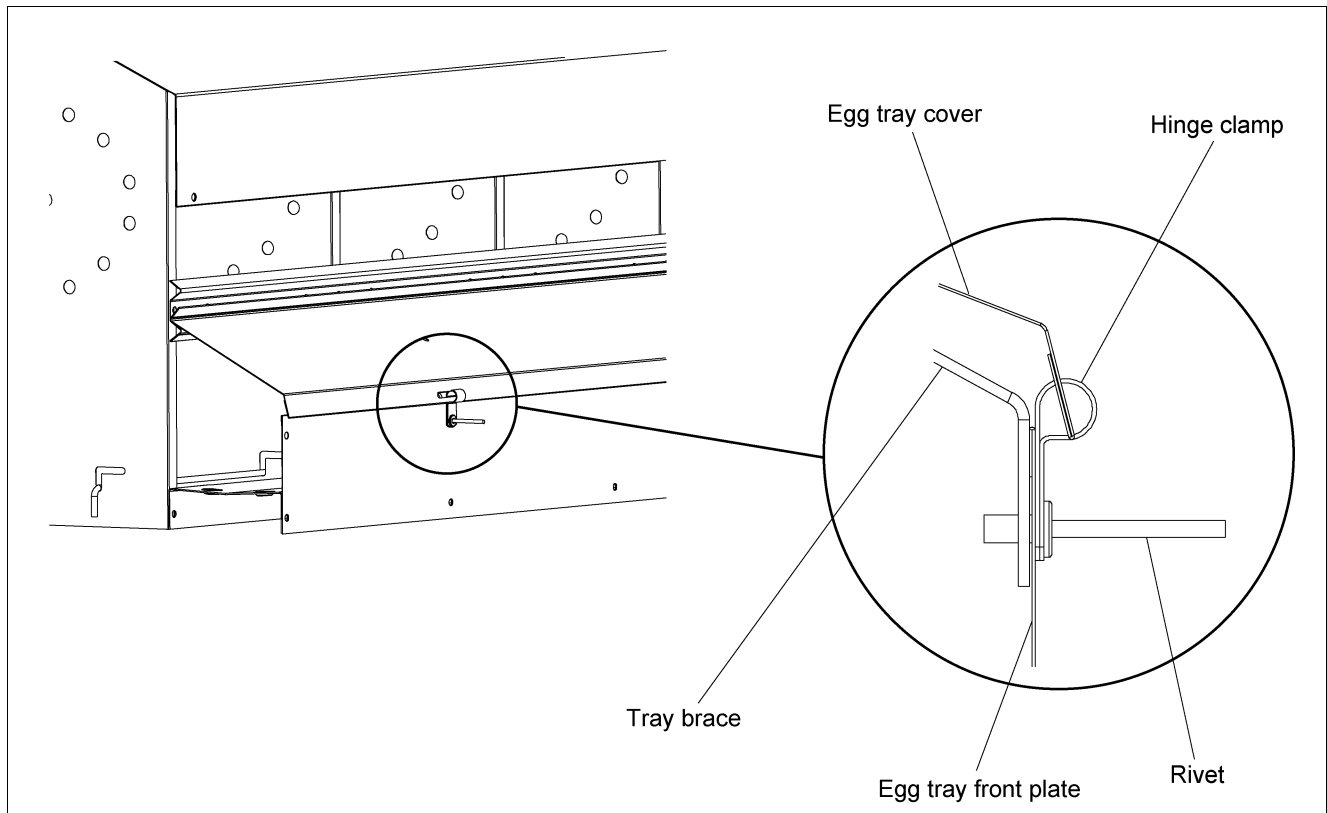

Figure 4L Hinge Clamp/Egg Tray Cover Assembly

Part #	Description	Qty
7101215	Tray Cover (FRN20)	2
7101297	Hinge Clamp (FRN20)	6
S-7060	3/16" Rivet Diameter, 7/16" Long Aluminium Rivets	6
C5000033	Tray Cover (FRN16)	2
7101297	Hinge Clamp (FRN16)	6

10. Place the egg tray cover/hinge clamp assembly created in [Step 9](#) on top of the tray braces previously installed in [Step 3, Figure 4F on Page 18](#). Insert a **S-7060 (3/16" rivet diameter, 7/16" long aluminium rivets) steel rivet** through the hinge clamp, the egg tray front plate (already in place) and finally through the tray brace (also already in place). Secure after making certain the rivet extends through each surface fully. Repeat this process for the remaining five (5) clips on both sides of the nest.
11. At this time, check to see that the swing top and egg tray cover operate properly. Swing top will close the nest when rotated downward and will open up the nest holes when rested on top of the fixed nest top. Egg tray cover locks into the stringer when closed and will rest on the egg tray front plate when rotated open.

FRN Front Rollout Nest Assembly Instructions (Continued)

12. Attach a splice plate under the egg tray using two (2) **S-7235 (rivet, PMG 3/16" diameter x 7/16" long ARSM) steel rivets**. Repeat for other side of nest on the same end. *(See Figure 4M.)*
NOTE: Splice plate is pre-assembled to aisle trays. Aisle trays are not shown for clarity.

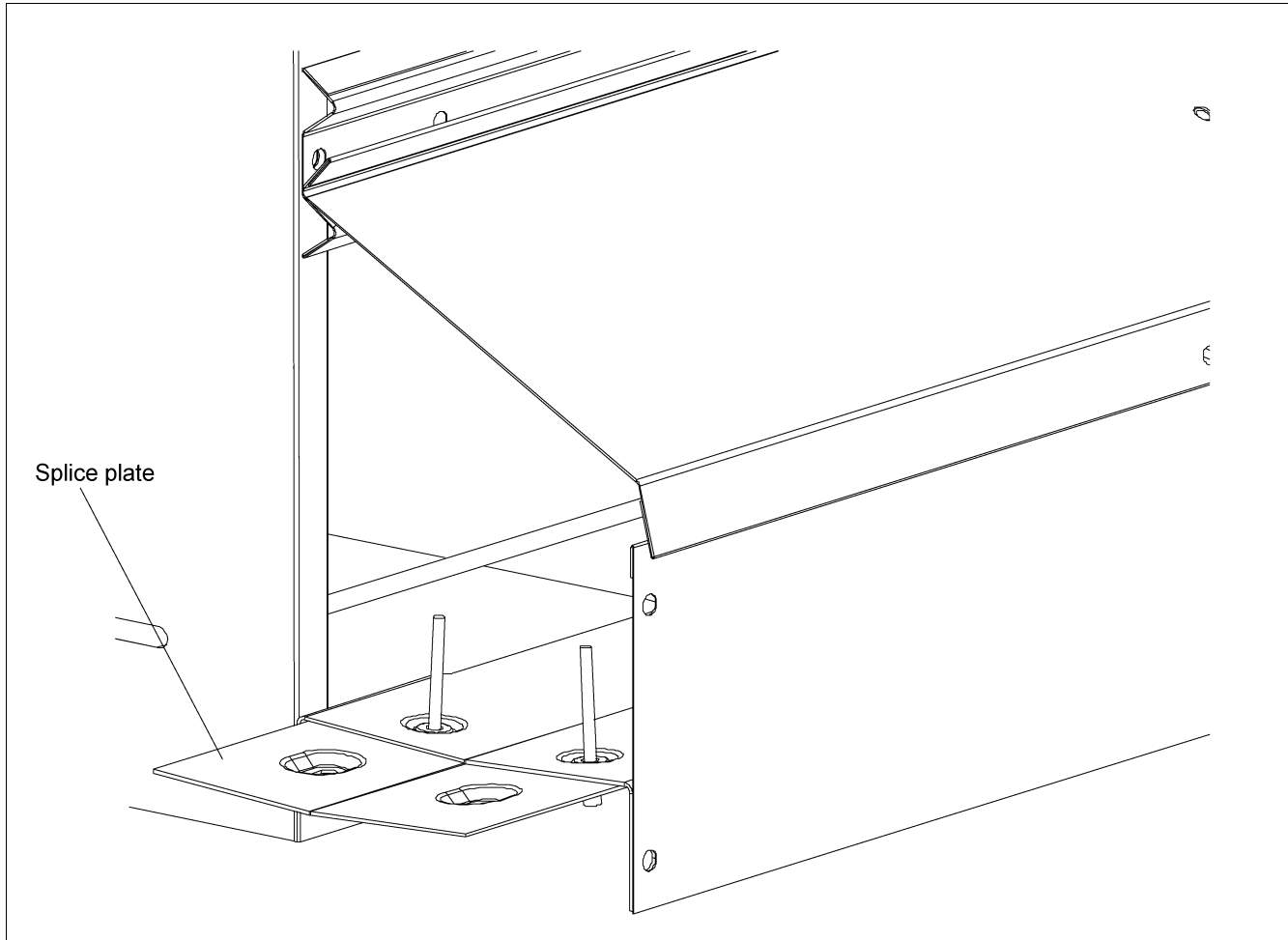

Figure 4M Splice Plate Assembly

Part #	Description	Qty
7101247	Splice Plate (FRN20)	2
S-7235	Rivet, PMG 3/16" Diameter x 7/16" Long ARSM	8
7101247	Splice Plate (FRN16)	2

FRN Front Rollout Nest Assembly Instructions (Continued)

13. Place perch bracket with the legs on the perch bracket against the egg tray cover. Insert a #10-24 x 2-1/4" screw down through the wood perch, perch bracket and egg tray cover and secure with a #10-24 nylock nut. Do not tighten completely until the wood perch is assembled onto all brackets. Repeat this step for the other three (3) brackets. Tighten all nuts until head of screw is flush with wood. Repeat this process on the other side of the nest. (See Figure 4N.)

NOTE: To use the wood perch without the perch bracket, simply place the wood perch directly on the egg tray cover and secure with a #10-24 x 1-1/4" machine screw (not supplied) and #10-24 nylock nut.

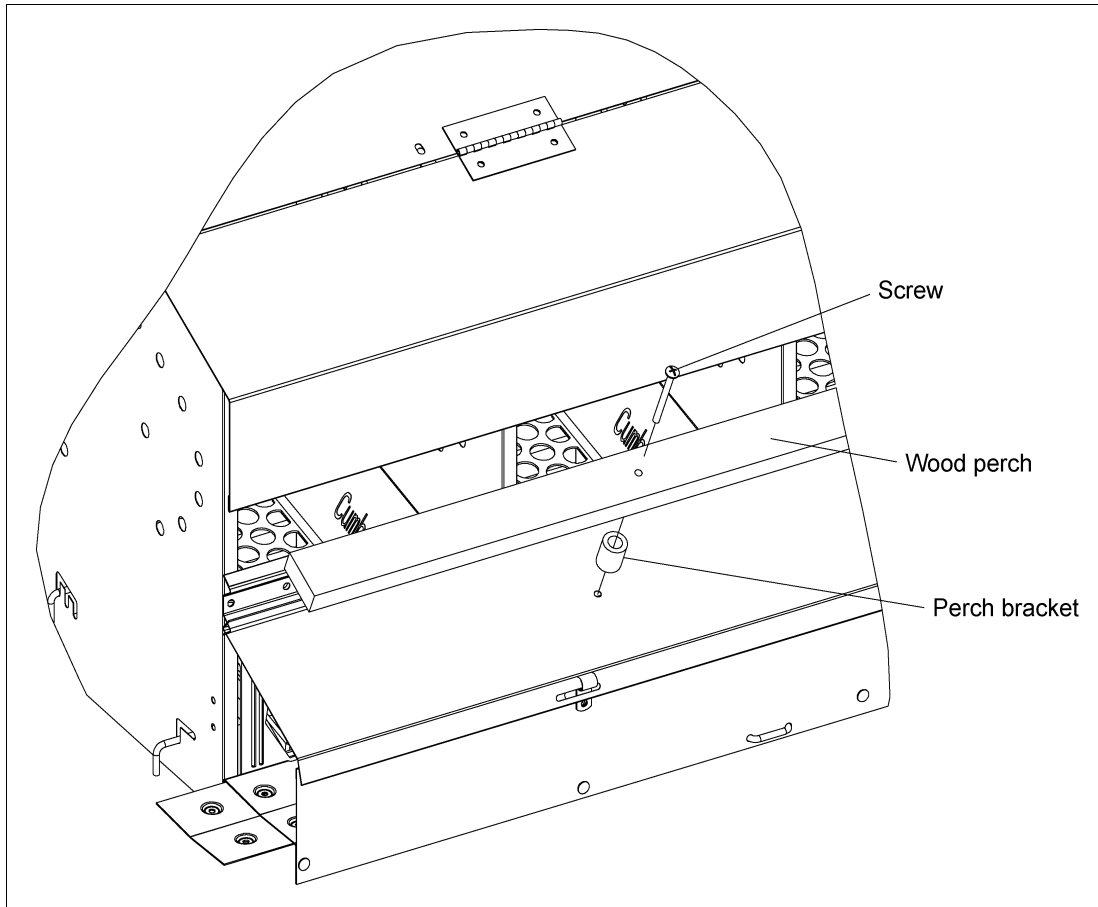

Figure 4N Perch Assembly

Part #	Description	Qty
S-10140	Spacer, Nylon, 0.194 (I.D) x 0.500(O.D) x 1.000 (Long) (FRN20/FRN16)	8
7101292	Perch (FRN20/FRN16)	2
S-8302	Screw (FRN20/FRN16)	8
S-2010	Nut (FRN20/FRN16)	8

FRN Front Rollout Nest Assembly Instructions (Continued)

14. Inside the nest hole, place the flat edge of the blinder up against the stringer (previously installed) and line up the holes in the blinder with the holes in the stringer. Secure in place with two (2) **S-7060 (3/16" rivet diameter, 7/16" long aluminium rivets) steel rivets**; rivets must be inserted from inside the nest hole out through the stringer so that the rivet expands against steel rather than plastic. (See [Figure 40.](#)) Repeat this process for the remaining nineteen (19) nest holes (fifteen (15) for FRN16).

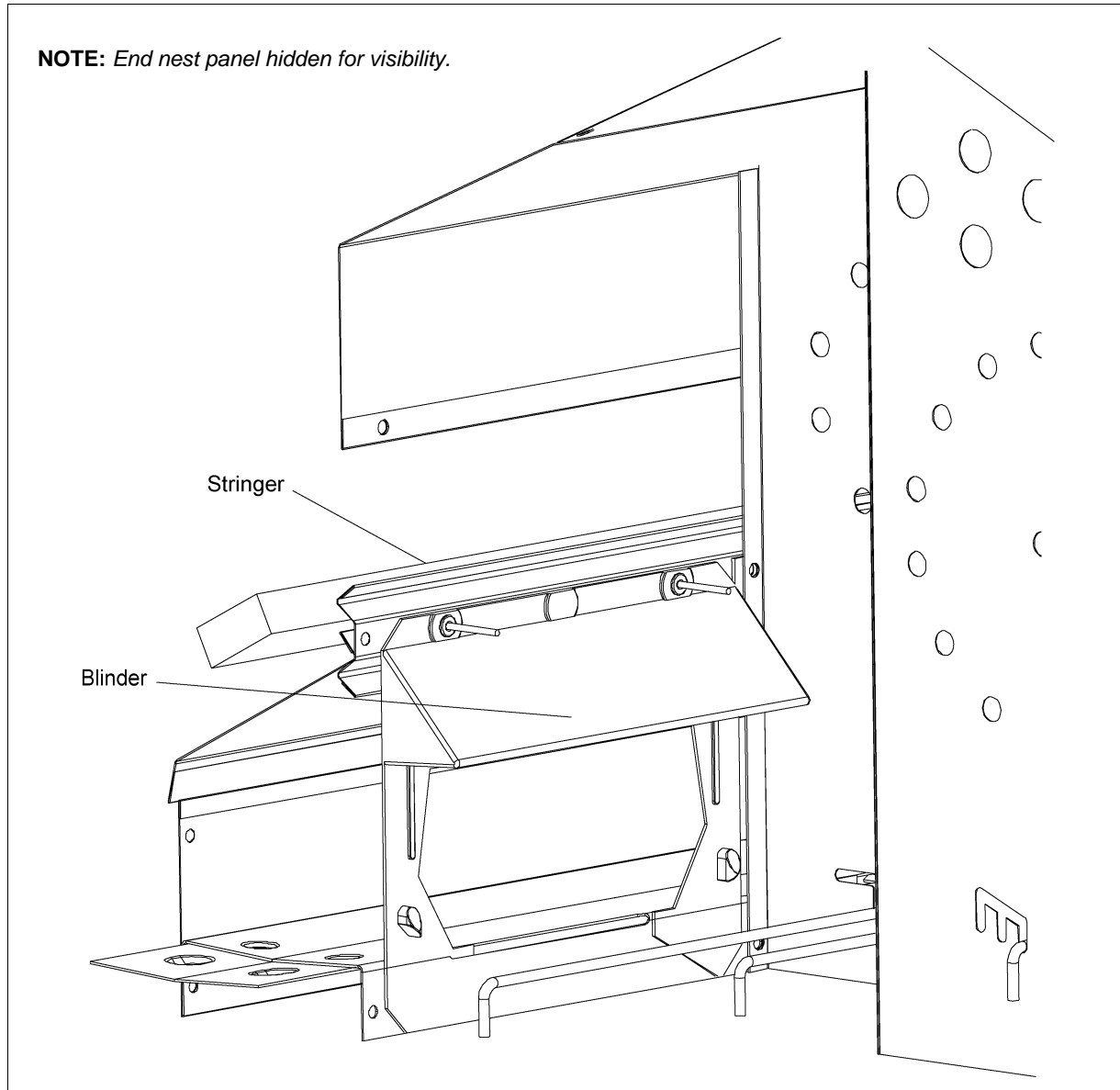

Figure 40 *Blinder Installation*

Part #	Description	Qty
7101296	Blinder (FRN20)	20
S-7060	3/16" Rivet Diameter, 7/16" Long Aluminium Rivets	40
C5000023	Blinder (FRN16)	16

FRN Front Rollout Nest Assembly Instructions (Continued)

15. Insert nest pad into nest bottom. Be certain pad is inserted fully below the six (6) fingers that protrude from sides of nest bottom. If using turf nest pad, be sure angle of crushed leaf is toward egg rollout. Repeat this process for the other nineteen (19) (fifteen (15) for FRN16) nest bottoms.
16. Inside the nest hole, place the nest bottom onto support rods previously installed and insert tab on front of nest bottom into the slot cut into the egg tray. Be certain the nest pad is snapped in place below the tabs on the blinder. Repeat for the other nineteen (19) nest holes (fifteen (15) for FRN16).
(See Figure 4P.)

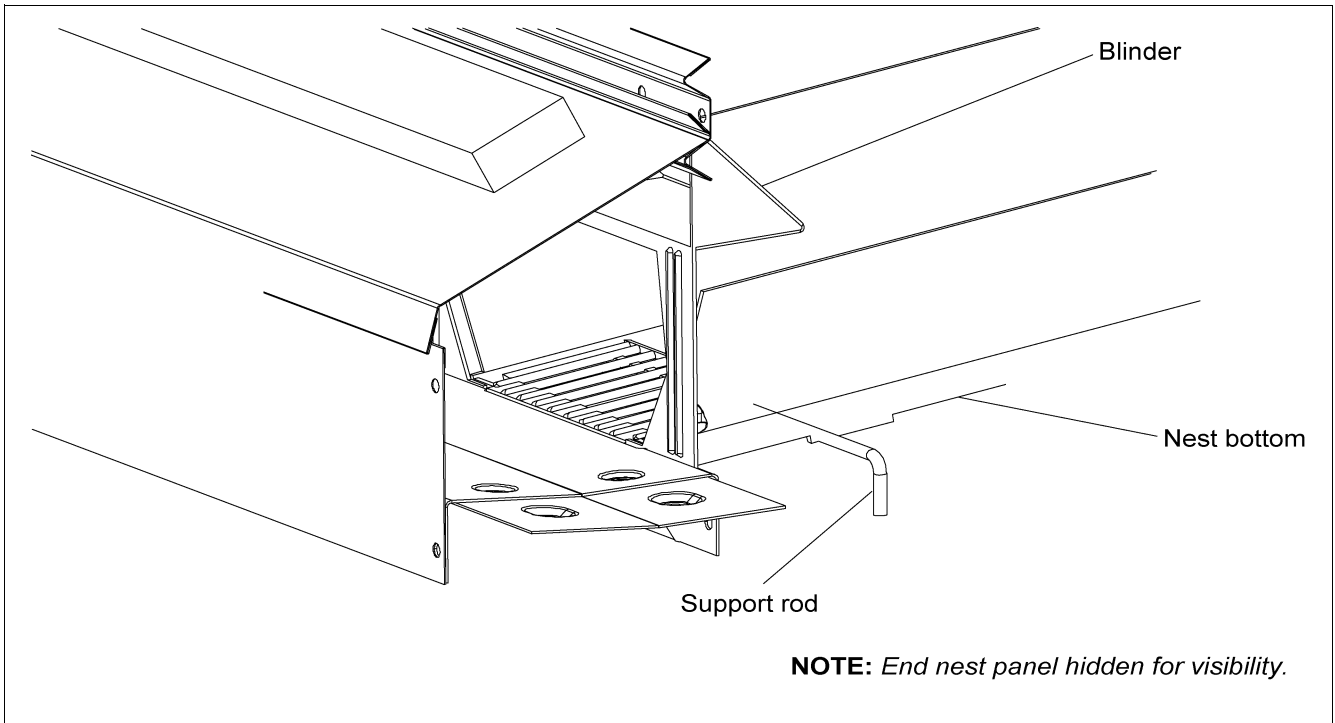

Figure 4P Nest Bottom Installation

Part #	Description	Qty
7101293	Nest Bottom (FRN20)	20
C5000022	Nest Bottom (FRN16)	16

FRN Front Rollout Nest Assembly Instructions (Continued)

17. Use S-7139 #10-24 x 3/8" screws, S-6151 #10 external tooth washers and S-849 #10-24 nuts to attach two (2) hangers and one flipper support bracket.

NOTE: The flipper support bracket should be attached opposite the winch brackets.

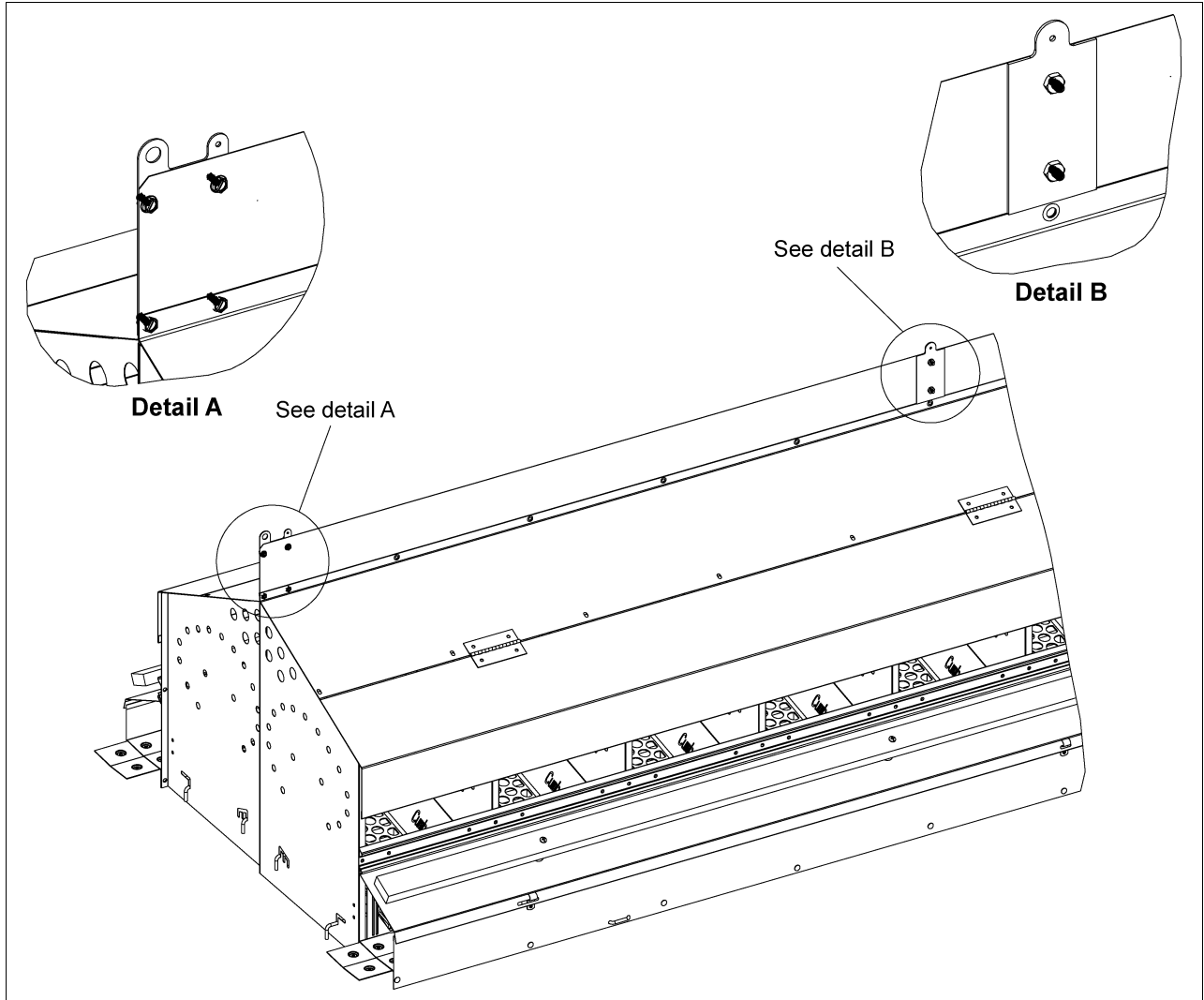

Figure 4Q Flipper Installation

Part #	Description	Qty
C5000104	Flipper Bracket (FRN20)	1
S-7139	#10 Screw (FRN20)	2
S-6151	#10 Washer (FRN20)	2
S-849	#10 Nut (FRN20)	2
C5000104	Flipper Bracket (FRN16)	1
S-7139	#10 Screw (FRN16)	2
S-6151	#10 Washer (FRN16)	2
S-849	#10 Nut (FRN16)	2

FRN Front Rollout Nest Assembly Instructions (Continued)

18. Place a C5000106 flipper onto tabs of the flipper brackets as shown. Secure the flippers using three (3) S-4322 3/32" x 1" cotter pins as shown in *Figure 4R*. Expand cotter pin. Flipper should freely rotate back and forth to keep birds off the top of the nest.

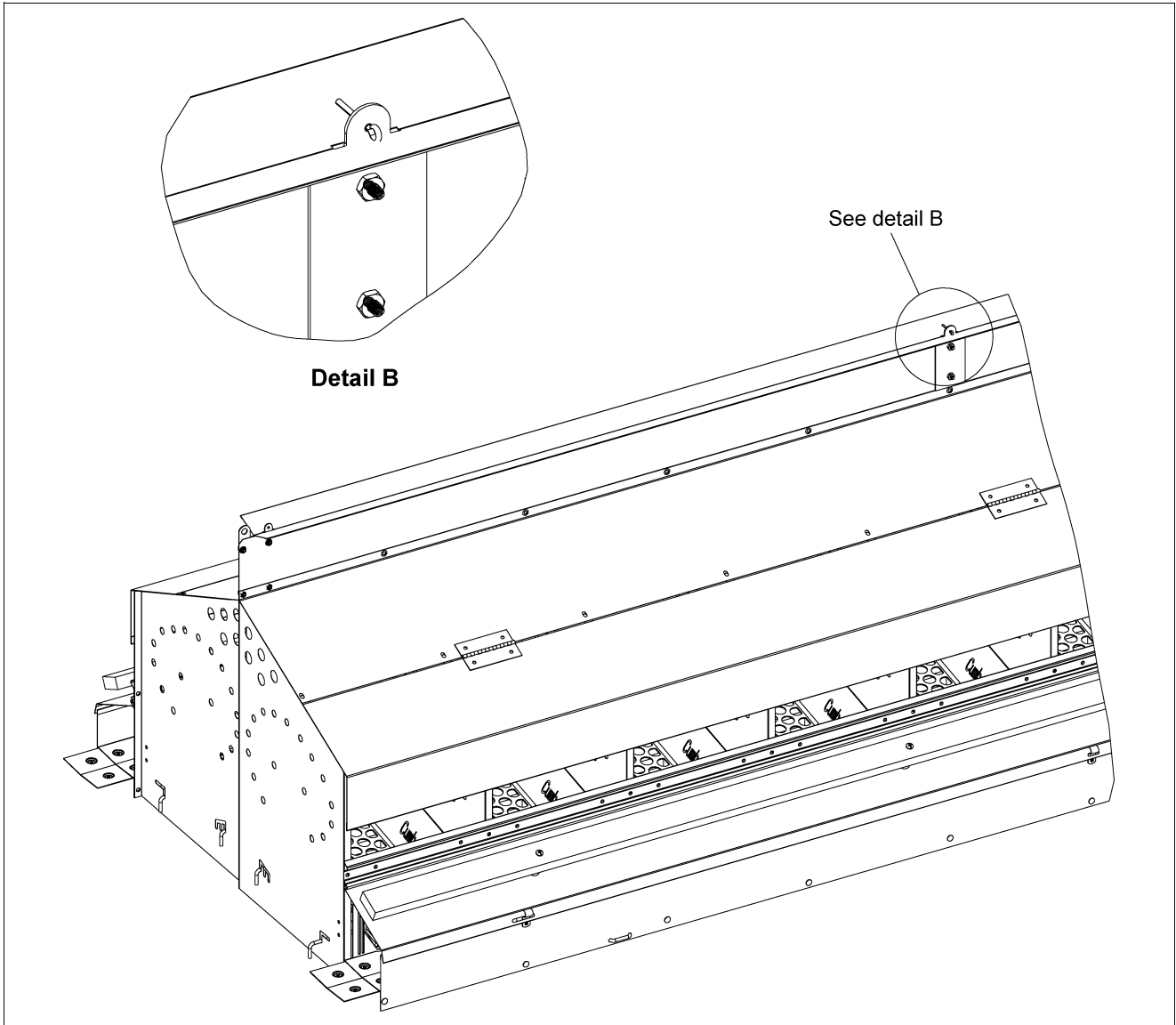

Figure 4R *Flipper Installation*

Part #	Description	Qty
C5000106	Flipper (FRN20)	1
S-4322	Cotter Pin (FRN20)	6
C5000106	Flipper (FRN16)	1
S-4322	Cotter Pin (FRN16)	6

19. Nest assembly is complete. Repeat process until all nests are assembled.

AN199 Egg Collector Assembly Instructions



BE CAREFUL, there are many sharp edges that can cut while assembling the AN199 Egg Collector. Wear protective clothing and gloves.

BE CAREFUL, the egg collector is heavy. Use caution when attempting to move.

Tools Required

1. Pneumatic pop rivet gun
2. Phillips and flat head screwdrivers
3. Pliers
4. Awl (optional)
5. Two (2) 7/16" and 1/2" wrenches or equivalent
6. Hot glue gun
7. Key-hole saw or equivalent
8. Needle and thread
9. Nylon cord to pull egg belt under nests

Number of Persons Required

For easiest assembly/installation of the AN199 egg collector, two (2) people should work together.

Be sure to read through each step completely prior to proceeding.

Assembly

1. Uncrate the assembled collector near where final placement will be. Note the height of slats in the chicken house; this height will determine the required table top height.
2. Attach the legs to the egg collector assembly in eight (8) locations as shown in [Figure 4T on Page 32](#). Place the legs on the collector such that the table top will be level with the slat height. (See [Figure 4S](#).) Use four (4) 5/16" bolts and nuts to attach each leg in the appropriate position. Space bolts out for maximum weight dispersion. (See [Figure 4T on Page 32](#).) Tighten nuts securely.

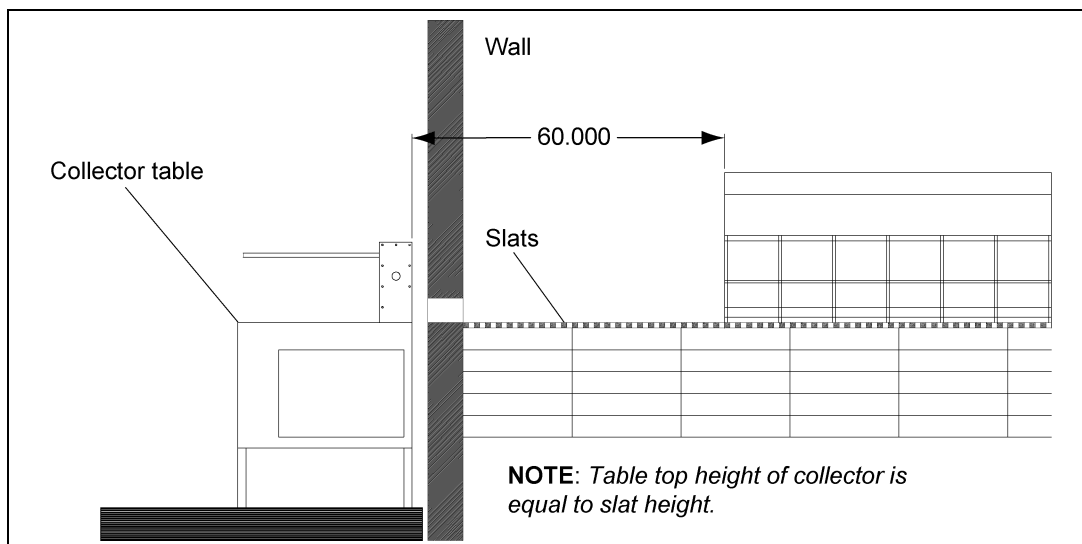

Figure 4S Elevation View of Collector Installation

AN199 Egg Collector Assembly Instructions (Continued)

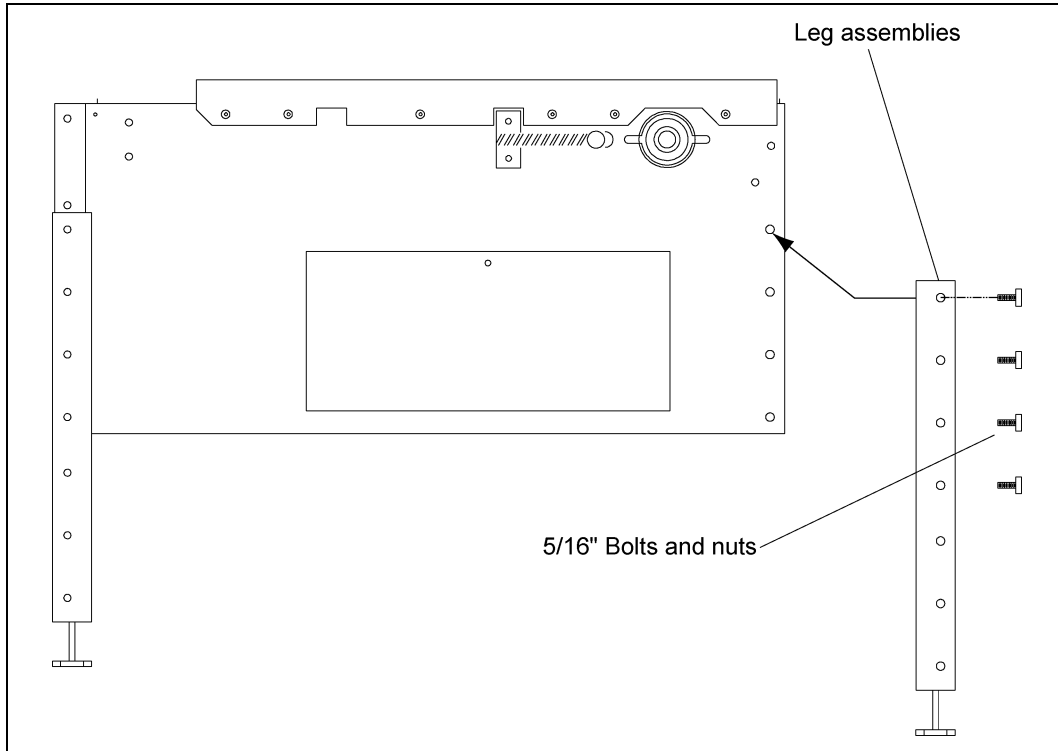

Figure 4T Leg Assembly



BE CAREFUL, use caution when performing the cutting operation.

3. Cut two (2) holes in the wall directly above the slats as shown in [Figure 4U](#). Hole location will vary with nest and collector placement. Be sure the diverter trays will go directly between the first nest and the egg collector.

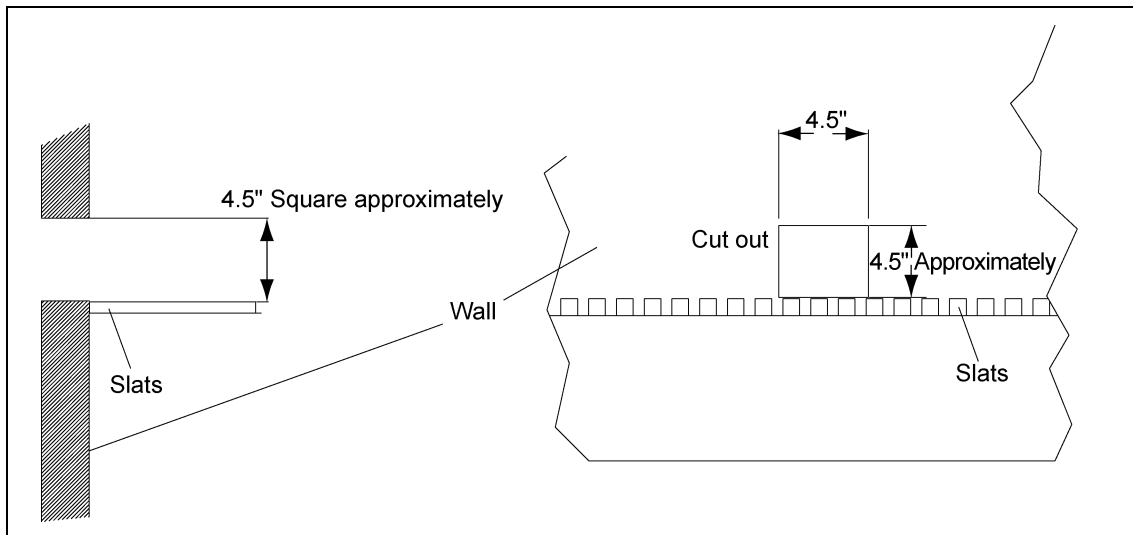

Figure 4U Wall Hole Detail

AN199 Egg Collector Assembly Instructions (Continued)

4. Place diverter trays through holes cut in the wall. Rivet the diverter trays to the splice plate of the first nest using two (2) 3/16" steel rivets per tray. Make certain the end of the diverter tray that has a bend in the center is toward the nest, flat end goes to collector. (See [Figure 4V.](#))

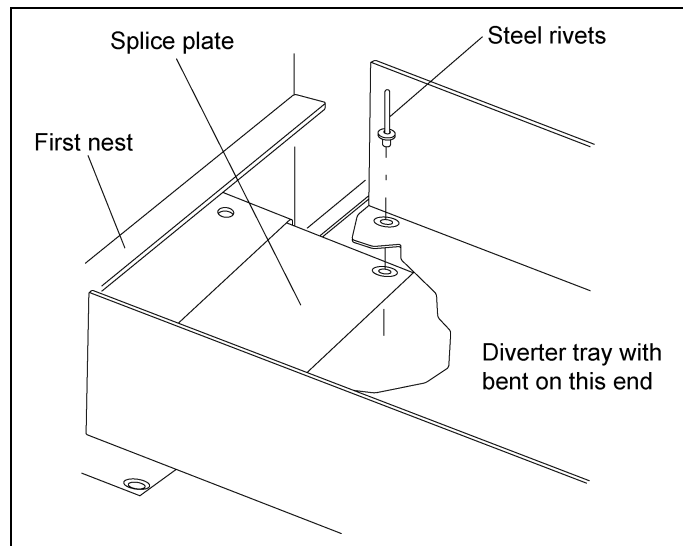

Figure 4V Diverter Tray Connection

5. Rivet the other end of the diverter trays to the table top of the collector using two (2) 3/16" steel rivets. Make certain the diverter tray is level. Raise or lower collector if needed to achieve this. (See [Figure 4S on Page 31.](#))
6. Once collector is leveled and diverter tray is secured to the nest and table top, secure the collector to the floor and the wall. Use the leg pad anchoring strips to surround the leg pads and anchor to the wall and floor. Anchor to the floor in the same manner as shown in [Figure 4W.](#)

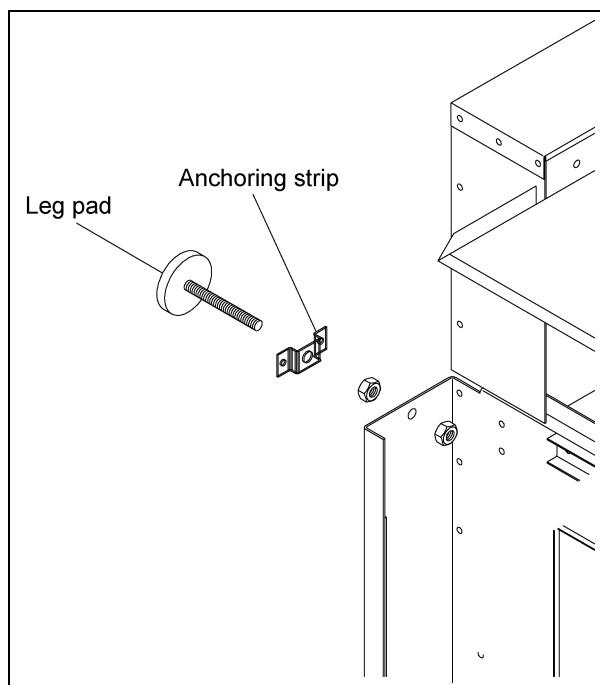

Figure 4W Anchoring Detail

AN199 Egg Collector Assembly Instructions (Continued)

Return Idler Assembly

Mount the return idler assemblies to the last nest's egg tray using four (4) 3/16" steel rivets per return idler. Place the tongue of the return idler under the egg tray and insert rivets from above the egg tray down. (See Figure 4X.) It is suggested to notch out the slats under the V-scraper to keep debris build-up minimized.

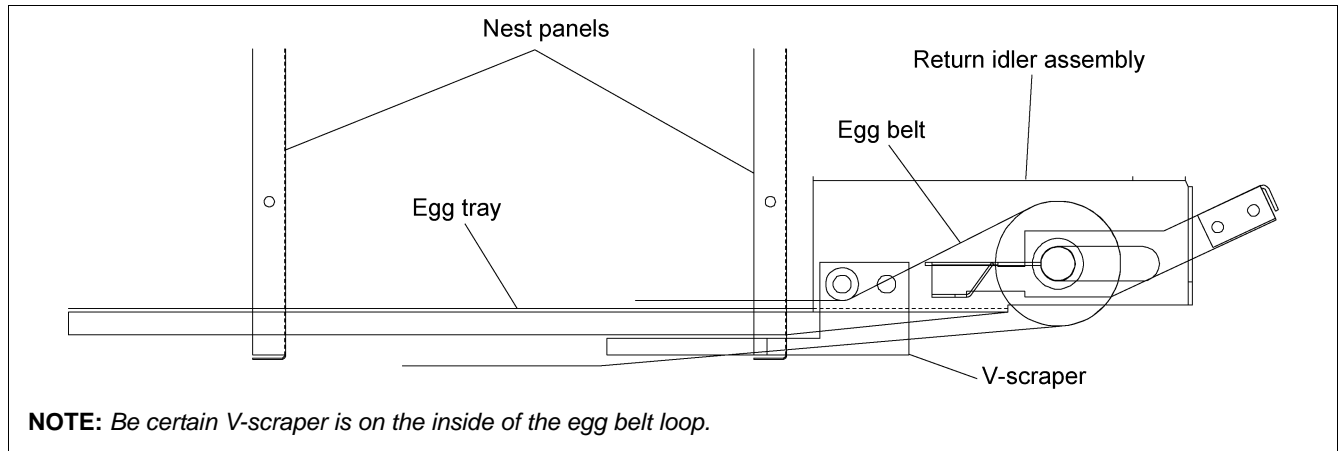

Figure 4X Return Idler Assembly

Aisle Tray Assembly

Rivet belt guides to aisle trays using 3/16" aluminium rivets. The procedure is the same as with the egg trays. (See Figure 4G on Page 19.) Attach aisle trays between nests with splice plates. As with the nest, splice plate extends under egg tray and aisle tray. Slot in splice plate should extend under the aisle tray. Secure using 3/16" steel rivets. (See Figure 4Y.) Install plastic aisle tray covers. Position one side of the plastic cover over the aisle tray. Then snap the other side over the opposite side of the tray.

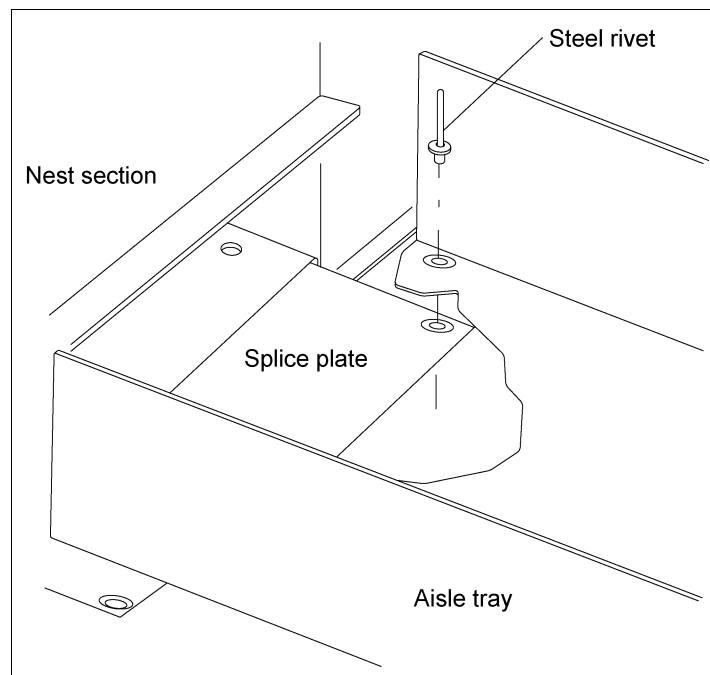

Figure 4Y Aisle Tray Assembly

AN199 Egg Collector Assembly Instructions (Continued)

Egg Belt Installation



BE CAREFUL, use caution when melting the belt to avoid burns.

NOTE: Refer [Egg Belt Care on Page 42](#) for tips on installation and care of the egg belt.

1. If possible, raise the nests off the slats 1'-2' (0.3 to 0.6 meter). Pull a nylon cord through the belt guides under the egg trays and aisle trays for the length of the house. **IMPORTANT:** Do not miss any belt guides; this cord will be tied to the belt at the return end of the house and be used to pull the belt.
2. Make a "V" on the end of the egg belt that will be pulled under the nests. This will aid in threading the belt under the nests and through the belt guides.
3. Pull egg belt off the roll from the drive end. It may be helpful to set up a stand with which to roll the belt off. Place the belt through the nests on top of the egg trays and aisle trays. Note any special instructions that are with the belt as to how to unwind the coil of belt.
4. Thread the belt through the return idler as shown in [Figure 4X on Page 34](#). Attach cord previously ran under the nests to the egg belt. Pull the belt to the drive table using the cord.
5. Double check to be certain that the egg belt has been threaded correctly through all rollers and that no belt guides have been missed. Lower the nests back to the slats.
6. Thread the belt through the drive mechanism as shown in [Figure 4Z](#).
7. With the proper tension on rollers, pull the top belt until the bottom belt begins to drift backward. At this point, lock the top belt against the wall of the house using two (2) wooden slat boards clamped together around the belt.
8. Pull the bottom belt until the drive mechanism is snug as shown in [Figure 4Z](#). Then stretch the belt NO MORE than 12"-18" (30-46 cm) past this point.

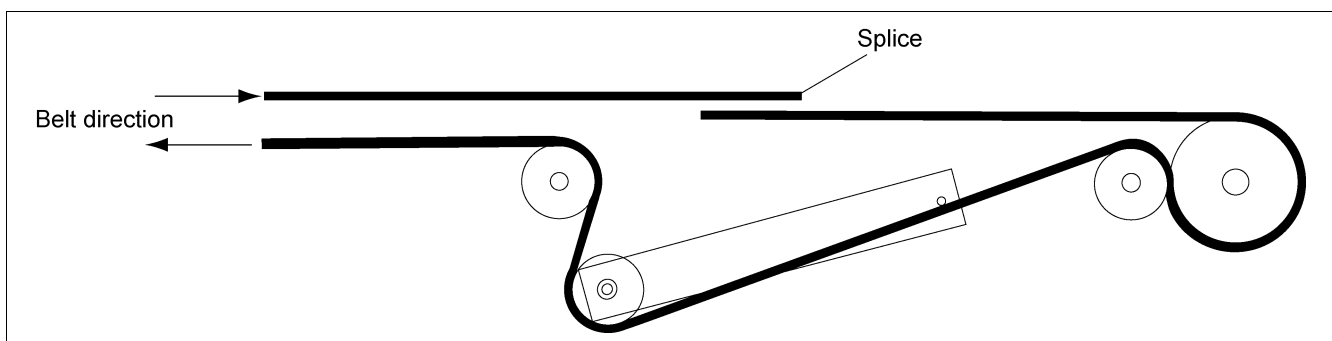

Figure 4Z Routing of Belt through Drive Mechanism

9. Working on the tabletop, overlap about 8" (20 cm), cut both ends of the belt off neatly. Take a lighter or torch and melt the cut edges to prevent fraying. ([See Figure 4AA on Page 36.](#))

AN199 Egg Collector Assembly Instructions (Continued)



BE CAREFUL, use caution when joining the belt to avoid burns from the gun or hot glue.

NOTE: Refer [Egg Belt Care on Page 42](#) for tips on installation and care of the egg belt.

10. Refer [Figure 4AA](#), glue a 4" x 8" (10 x 20 cm) section at a time (or half of the splice). **NOTE:** The splice must be made within fifteen (15) seconds from the time of glue application. Work quickly, but be sure edges of belt are aligned prior to compressing. Be sure to use enough glue to get a little oozing of glue at the edges of the belt.
11. Glue the other section of the splice once the first section is dried sufficiently. Work in the same manner as in [Step 10](#). After final application is done, place a bead of glue on the edge of the belt and feather to make certain the travel of the belt is smooth.

NOTE: It is recommended to also sew the belt at this time. Sew each edge of the belt (including the bottom edge) as well as sewing an "X" across the overlap. Be certain not to leave any edges of the belt sticking out or loose.

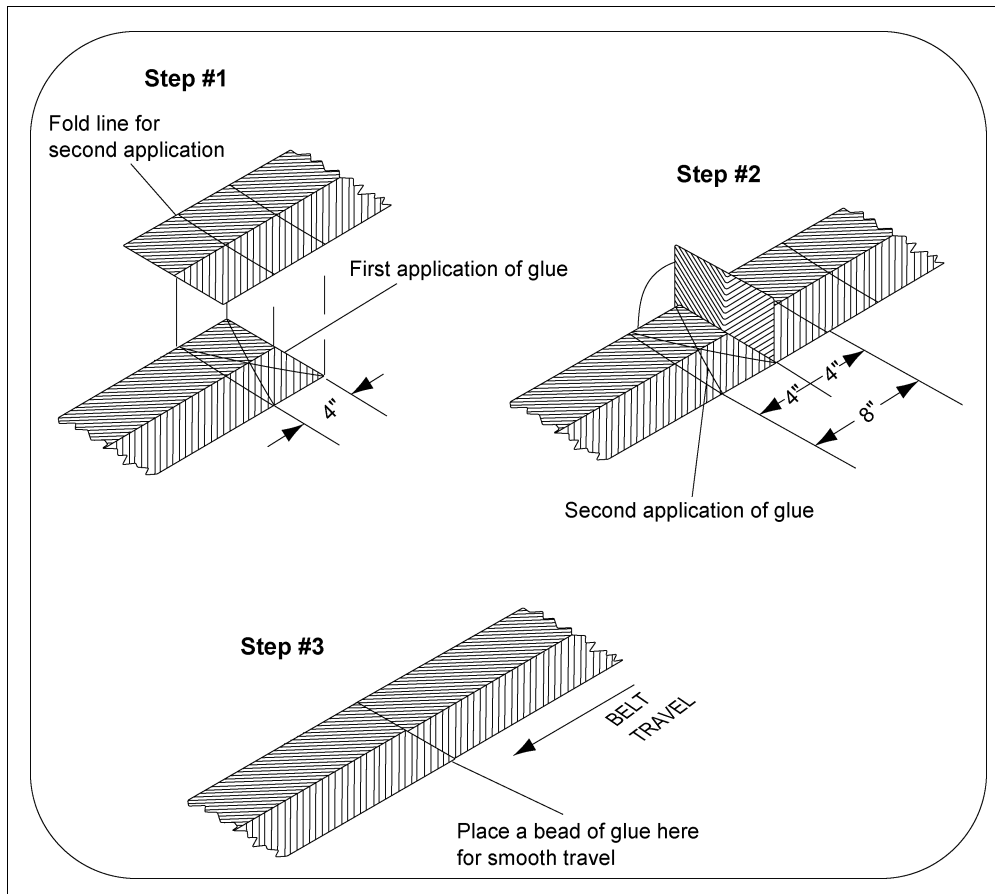

Figure 4AA Belt Splicing/Gluing

12. Tension on the belt will need to be checked often. The belt must be stretched slowly over **several weeks**. The increased egg load from a young flock of birds coming into production is a perfect method of stretching the belt. The belt will need to be shortened 2-3 times during the first several weeks of use. Take out only the excess belt and do not over-stretch.

AN199 Egg Collector Assembly Instructions (Continued)

Egg Belt Adjustment

1. To adjust tracking of the egg belt, loosen the bearing assembly nuts and the nut on the back side of the adjustment bracket. Next, tighten the nut on the front side of the adjustment bracket until the egg belt tracks straight. Then tighten the bearing assembly nuts and the nut on the back side of the adjustment bracket to lock the adjustment bolt in place. This may be performed on either side of the drive assembly. (See [Figure 4AB.](#))



Figure 4AB

- a. Tracking may also be adjusted at the return idler. Loosen the locking nuts on the return idler bracket and tighten the nut against the bracket in the direction you wish to move the return roller. Tighten the opposing nut to lock the idler in position. This step may be performed on either side of the return idler assembly.
2. To increase the egg belt tension, compress the spring by tightening the lock nut. Repeat for the other side of the egg table. Tables are shipped with the pinch roller loose for easier installation of the egg belt. The pinch roller shaft **MUST** be adjusted the same on both sides of the nest to have proper tension and tracking. (See [Figure 4AC.](#))

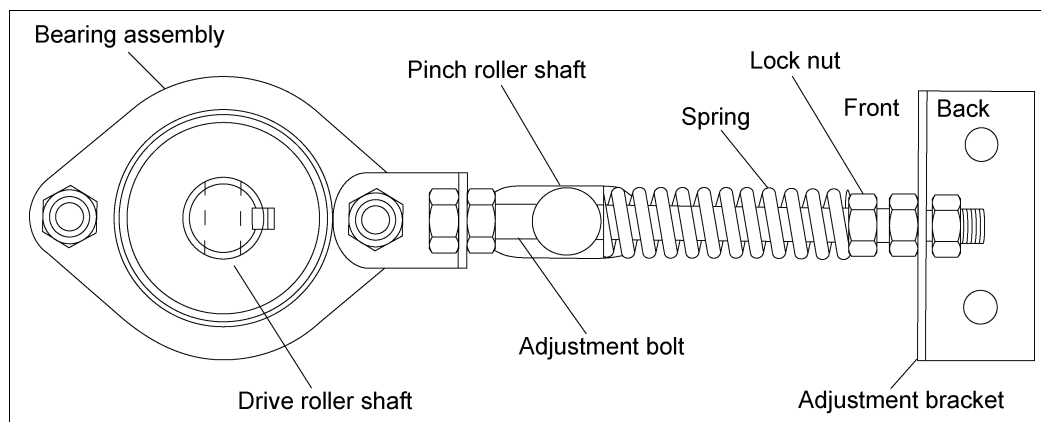

Figure 4AC Egg Belt Adjustment

If additional adjustment is needed, it may be necessary to loosen the motor mount plate bolts along with the inner bearing bolts on both sides and slide the motor mount plate either forward or backward. Re-tighten them and then make tracking adjustments again to the outside bearing assemblies.

4. Installation Instructions

Diverter Installation

1. Lock out power to the egg collector. Place diverter over the lip of the egg table to secure. Repeat both sides. ([See Figure 4AD.](#))

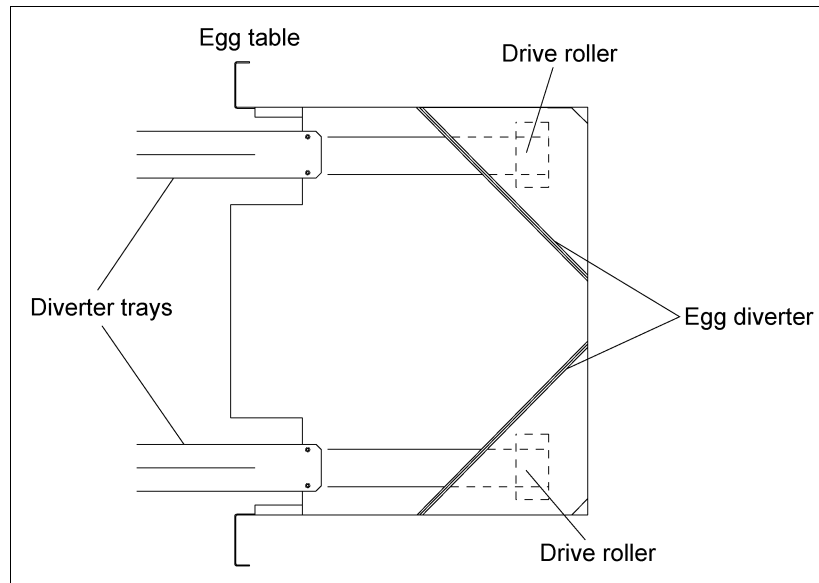

Figure 4AD Diverter Installation

Electrical Installation for AN199 Egg Collector

To ensure the safety during installation, make all electrical connections as the final step of installation. This should be done only when the egg collector has been fully installed and all guards and covers are fixed in place. Electrical connection should be carried out only by a qualified electrical installer and should be to the relevant rules and directives in force in the region.

A grounded receptacle is required at each collection table for the drive. Each table should be wired on its own circuit with a mains isolator. A grounded male cordset is furnished for plugging to grounded receptacle. [See Figure 5A, Figure 5B on Page 39](#) and [Figure 5C, Figure 5D on Page 40](#) for wiring diagrams that are applicable to the installation. Provision of an adequate and safe power supply to the Egg Collection System unit is essential to the safety. Cumberland recommends that a competent and qualified electrician undertake all electrical wiring. All wiring is to be installed to the National Standards and Regulations relevant to the Country and Region.

1. Mount the speed control mounting bracket to the anchoring pad stud of one of the outside housing panels. Place the speed control box over the screws already secured in the mounting bracket. Slide the speed control down into the slots of the holes to “lock” it in place. Plug the yellow quick disconnect cord into the speed control assembly and screw in hand tight. (The other end of the quick disconnect cord has been factory wired into the electrical box of the egg collector assembly.)
2. Set ON/OFF power switch to “OFF”. Make certain the FORWARD/REVERSE switch is set “FWD”. Plug the power cord into the grounded receptacle.
3. Turn the ON/OFF power switch to “ON”.
4. The speed control has been pre-set at the factory and does not require adjustment. Turn the speed control knob to verify the operation of the drive roller and conveyor belt. Motor should increase/decrease speed gradually as the knob is turned and operate smoothly. If adjustment is necessary, contact the nearest Cumberland dealer for instruction. See [Operating the Speed Control Assembly on Page 43](#) in this manual for operating instructions.

AN199 Egg Collector - 115 Volt 1 Phase Wiring Diagram

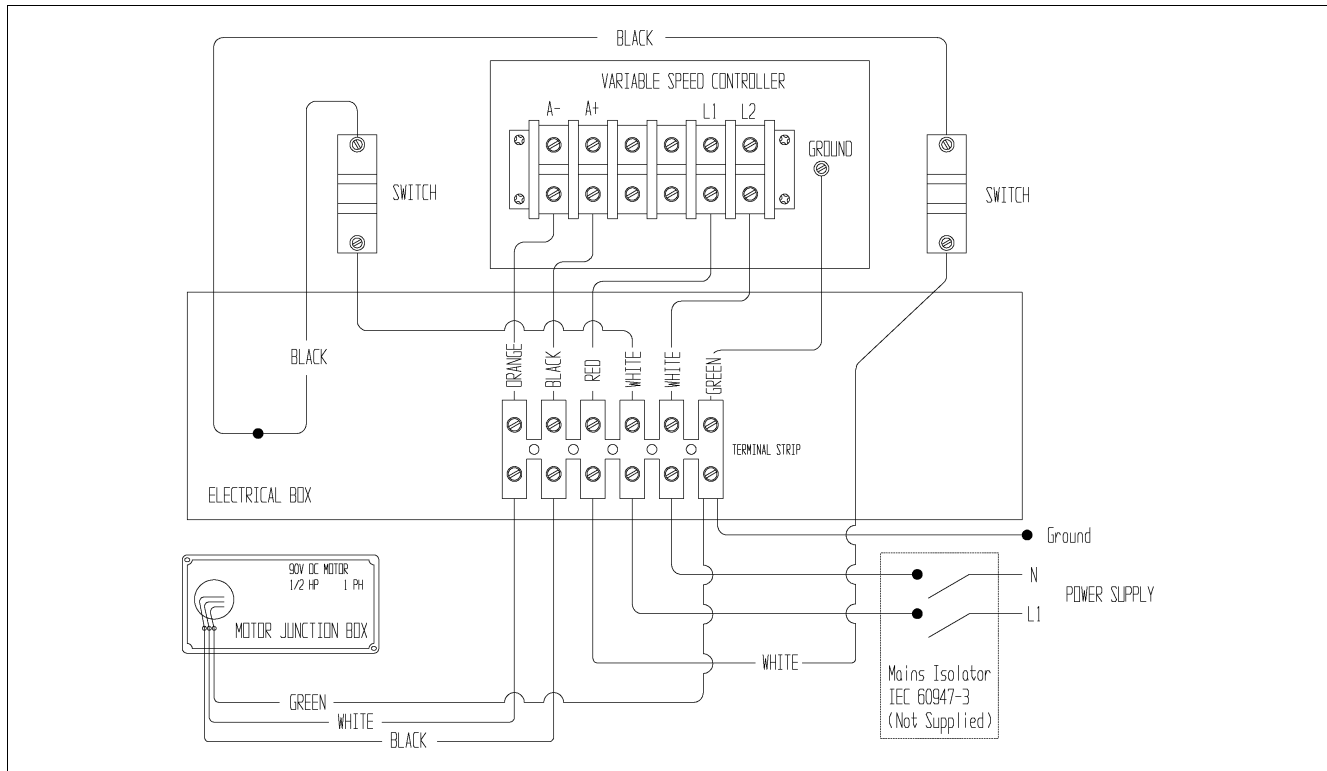

Figure 5A 120V 1 Phase Wiring Diagram

AN199 Egg Collector - 220 Volt 1 Phase Wiring Diagram

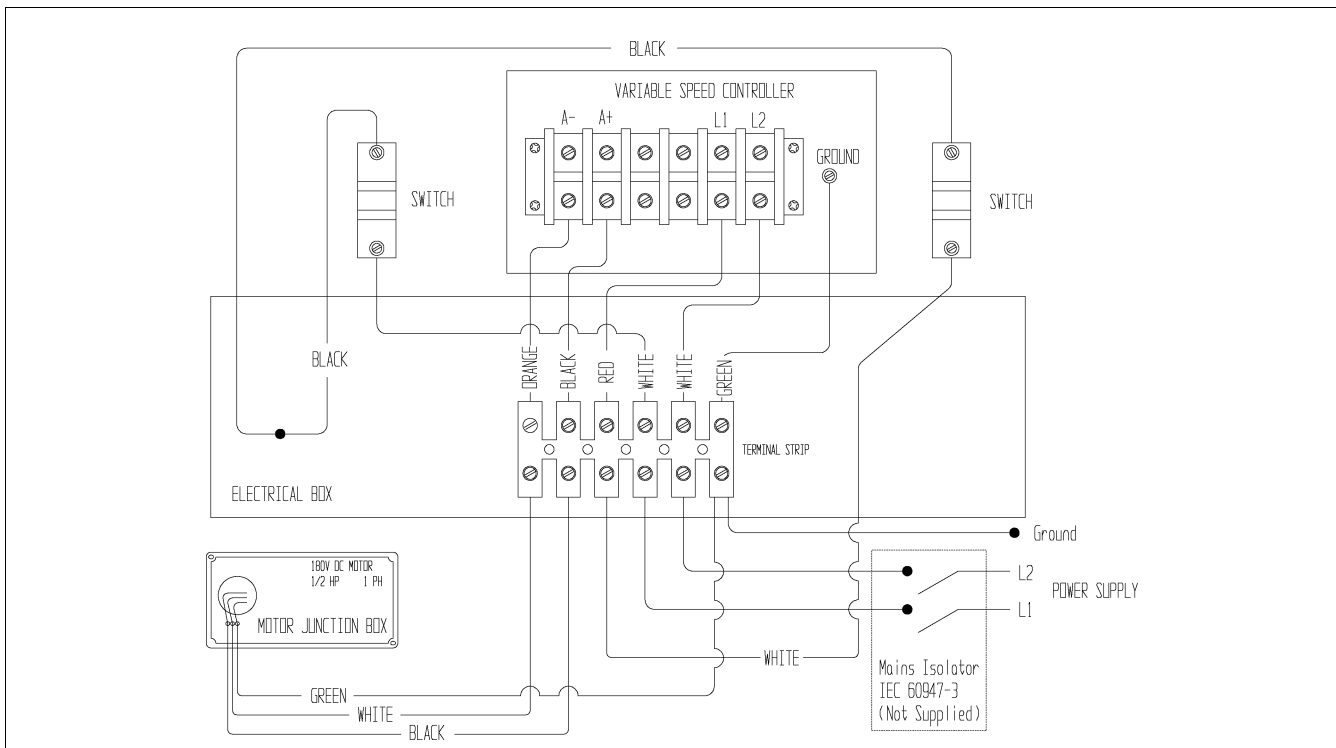

Figure 5B 220V 1 Phase Wiring Diagram

AN199 Egg Collector - 220 Volt 3 Phase Wiring Diagram

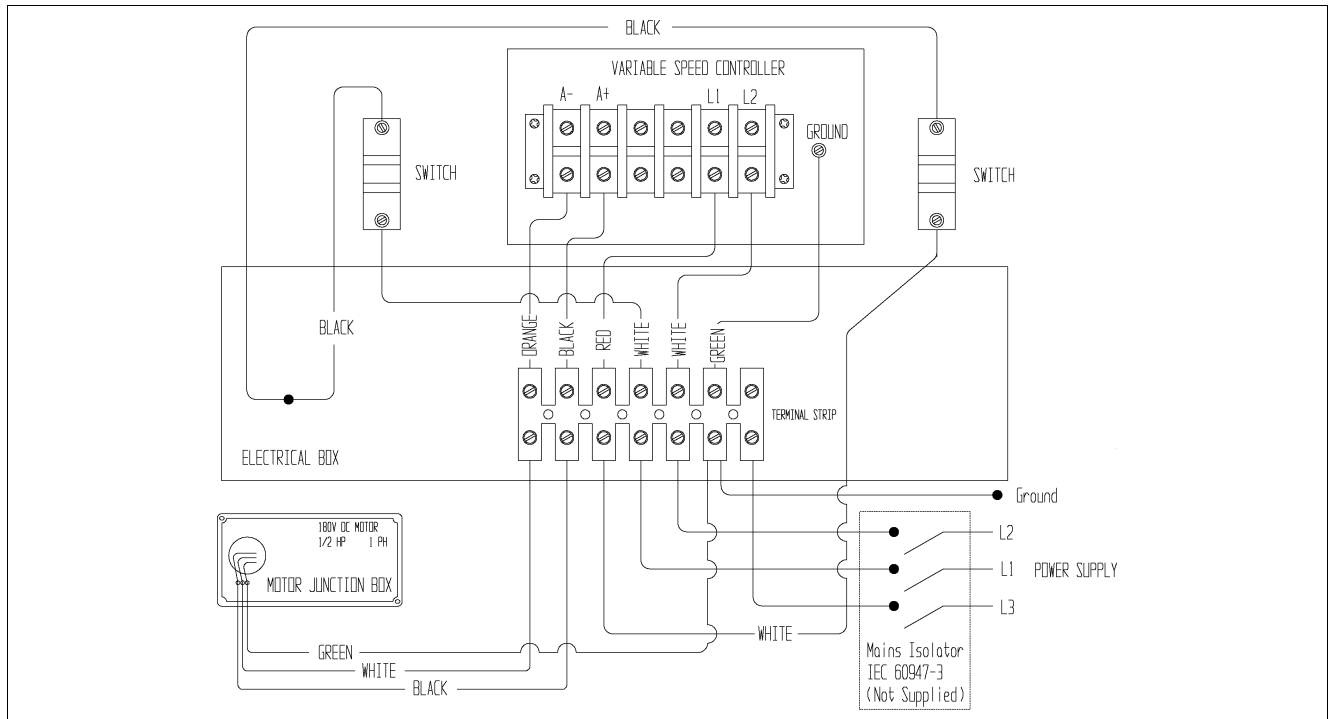

Figure 5C 220V 3 Phase Wiring Diagram

AN199 Egg Collector - 380 Volt and 415 Volt 3 Phase Wiring Diagram

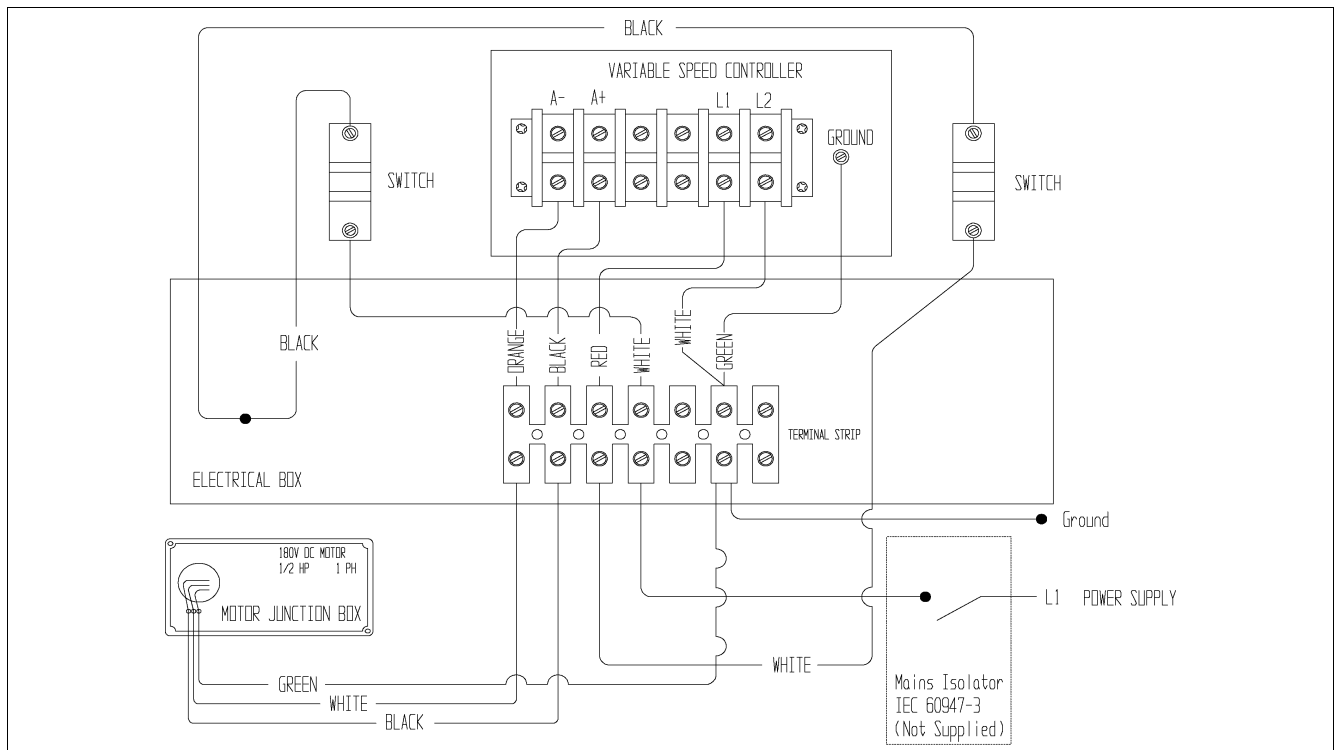

Figure 5D 380V and 415V 3 Phase Wiring Diagram

While the Egg Collection System is designed to keep maintenance to a minimum, some repairs will be necessary in the course of the life of the machine. Do not attempt any repairs on the machine unless you are competent to do so.

Before starting any repairs or maintenance on the Egg Collection System, observe the following safety steps:

1. Isolate the whole system from the electrical supply by switching OFF the power isolator and locking it.
2. Keep the key in the possession.
3. Beware in making any repairs to the collection belt. It may be under some degree of tension. Avoid touching the belt with the hands until you are sure that it is loose at all points. Use a suitable tool to check the belt.
4. Do not re-connect the power supply until all work is completed and all guards are correctly re-fitted.

Operation Maintenance

1. Check belt tension periodically. Make certain the belt is stretched properly, but not over-stretched.
2. Inspect belt splices everytime eggs are collected. If splice is ragged or frayed, cut the belt and create a new splice per instructions in this manual.
3. Lock out power to the system prior to removing any guards. Inspect the entire drive mechanism for the accumulation of debris within the system. Use a vacuum to remove dust and debris. Lubricate bearings as necessary. Replace all guards prior to restarting the system.
4. Inspect conveyor brushes at the egg table and return idlers. Adjust so that the sweeping action of the brushes is properly maintained without destroying the integrity of the brush. Wear to the brush should be minor.
5. Remove and clean nest pads regularly as needed. Have extra pads on hand to replace the dirty pads as they are removed. Soak dirty pads and brush clean if necessary. Consult the integrator as to the cleaning agent to use. The pad is designed to be very durable; years of useful life can be expected with proper care.
6. Clean dust from the drive motor as needed to keep the motor running cool. Use a vacuum for this job, never use a liquid at any time on any electrical components.
7. Check drive rollers and belt rollers for wear. Clean as needed and replace if wear is excessive. Inspect all bearings to be sure they are operating properly.

Between Flock Maintenance

The nest system may be sprayed clean and disinfected as needed. When cleaning egg belt, use high pressure water. Avoid getting any liquid on the electrical components, motor or drive components. Clean these areas with a vacuum. Go through the operation maintenance checks above prior to restarting the system.

Egg Belt Care

The following are recommendations for the installation, care and maintenance of the egg collection belt. The belt is warranted by the manufacturer for defects. Continually inspect the belt after initial installation and after any adjustments for tracking, etc.

- Install the belt as instructed in this manual. Check that all splices are correct. They should be lapped in the proper order and straight so as to not cause the belt to run out of line when collecting eggs.
- Make certain nests are level and shim where necessary to ensure the belt has level travel. Make certain all nests and the collector are aligned so that the belt runs in a straight line and does not rub the sides of the nest.
- Assemble the nests and collector properly so that there are no sharp edges or protruding rivets that could snag and tear the belt. Make sure there are no slat boards, or nails from slat boards, sticking up that could catch the egg belt.
- All egg belt is woven in a relaxed condition. It must be stretched slowly over **several weeks**. The increased egg load from a young flock of birds coming into production is a perfect method of stretching the belt. The belt will need to be shortened 2-3 times during the first several weeks of use. Take out only the excess belt. Once the birds have reached peak production and egg size, the belt will not continue to stretch. Do not install a new belt in a house with birds in peak production unless it is an emergency.
- Do not overstretch the belt. Run the belt as loose as possible without interfering with the drive system. Running a belt too tight causes poor performance, decreased belt life and excess wear on the system. A belt stretched too tight cups up on the sides allowing eggs to get under it. This starts a chain reaction which many times results in the belt becoming permanently creased and unusable.
- Keep the belt clean. Clean up any broken eggs as soon as discovered. Use plain water so as to not destroy the protective coating in the fibres of the belt.
- At the collector and return idlers, keep the belt brushes and scrapers clean and at the proper depth to do their job.
- Immediately investigate any frays, tears or suspicious inconsistencies in the belt and correct the problem.
 - Check for rodents that feed on the belt and debris left on the belt.
 - Check the tracking of the belt to be sure it is running unobstructed.
 - Again, check for proper installation of the nest assembly and collector.
 - Burn and seal off any frayed edges or frayed holes in the belt to prevent unraveling.
- Collect the eggs often. Too many eggs on the belt causes excessive tension and wear.
- Work to control rodents in and around the house. Not only will they damage egg belt, but curtains and evaporative cooling pads are also susceptible.

Operating the Speed Control Assembly

The KB speed controller should only be serviced by a qualified technician, electrician or electrical maintenance person familiar with its operation and the hazards involved. Eye protection must be worn and insulated adjustment tools must be used when working with the control.

- The black knob on the speed control will operate the motor from 0-40 per minute (0-12 m/min.). Use the control knob to start/stop the belt. DO NOT use the ON/OFF switch to start and stop the belt.
- To aid in installation/maintenance of the egg conveyor, the control has a forward/reverse switch. To reverse the system: Turn the control knob to the “zero” position, turn the ON/OFF power switch to “OFF”, remove the cotter pin from the bracket and flip the toggle switch to “reverse”. To return to normal operating position: Turn control knob to “zero” and power switch “OFF”, flip the toggle switch back to forward, replace the cotter pin and run the system as usual. NEVER FLIP THE FORWARD/REVERSE TOGGLE SWITCH WHILE THE CONVEYOR IS IN OPERATION.
- Supply line must be $\pm 10\%$ of the required voltage.
- The egg collector has a limit switch to stop the motor if too much slack develops in the line. If this occurs, lock out power to the system, cut the belt, re-stretch and re-splice. Restore power to the system and operate as usual.
- The controller is equipped with line and armature fuses. If you suspect either of these fuses is blown, lock out power and remove the cover of the control. Visually inspect the fuses and check for continuity. Replace fuses if necessary. Replace cover before restoring power to the unit. Contact a qualified electrician or the Cumberland dealer for further assistance if needed.
- The speed controllers come preset from the factory. Through the use of a test station, the current limit, IR comp and the maximum and minimum speed trimpots are set. It is important to note that when any one of the trimpots is changed, it affects all the other settings. For example, if the maximum speed gets turned up early in the flock when there are few eggs on the belt (the load is light), later in the flock, when there are more eggs and a heavier load, the speed controller can no longer pull the belt. These settings should only be adjusted by trained and qualified personnel.
- The speed controller should **not** be turned OFF and back ON when the quantity of eggs becomes too heavy for the operator. Rather, the speed control knob should be used to increase and decrease the speed. The controller should be turned ON at the beginning of collection and OFF only when collection time is over.
- The speed controller is delivered to the customer with the forward/reverse switch prevented from working by a cotter pin. This cotter pin needs to be in place during normal operation. This prevents accidental reversal of the speed controller while it is running. When in operation, if the operator mistakenly hits the forward/reverse switch to turn the controller OFF rather than the power switch, the board inside the controller blows which then requires a brand new speed controller. (This is not covered by warranty.)
- See the troubleshooting guide in the back of the speed control manual for solutions to common problems. If trouble persists, contact the distributor, technical salesperson or Cumberland direct.

FRN16, FRN20 Nest Assembly

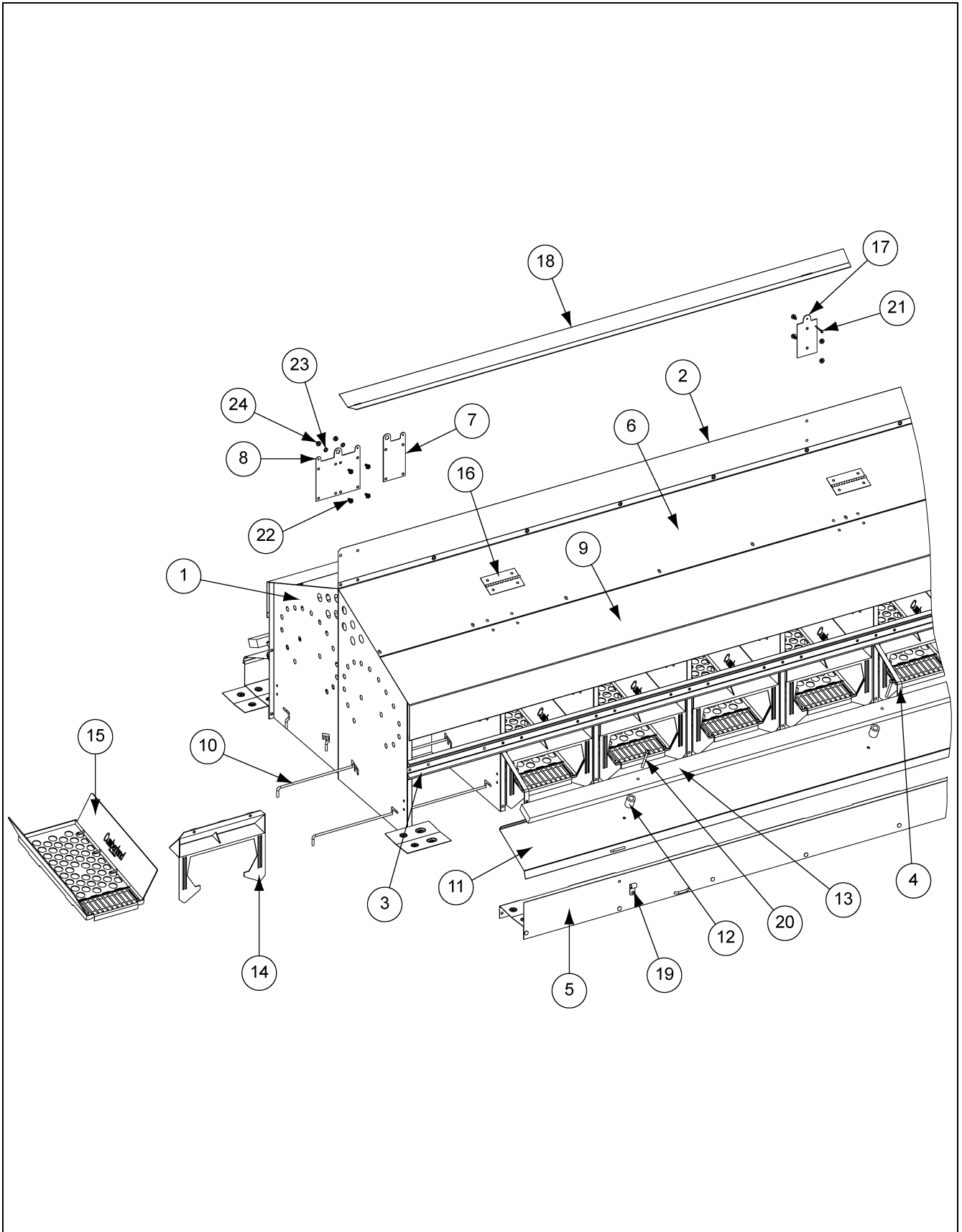

FRN16, FRN20 Nest Assembly Parts List

Ref #	Part #		Description	Qty	
	FRN16	FRN20		FRN16	FRN20
1	C5000206	C5000206	Nest Panel	18	22
2	C5000028	7101219	Back Panel	1	1
3	C5000031	7101218	Stringer	2	2
4	7101206	7101206	Center Tray Brace	6	6
5	C5000109	C5000102	Egg Tray/Front Plate Assembly	2	2
6	C5000029	7101217	Nest Top	2	2
7	C5000103	C5000103	Hanger, End	2	2
8	C5000107	C5000107	Hanger, Double	1	1
9	C5000043	C5100000	Swing Top with Decals	2	2
10	C5000026	C5000026	Support Rod	4	4
11	C5000033	7101215	Egg Tray Cover	2	2
12	S-10140	S-10140	Spacer, Nylon,0.194 (I.D) x 0.500 (O.D) x 1.000 (L)	8	8
13	7101292	7101292	Perch Board	2	2
14	C5000023	7101296	Blinder	16	20
15	C5000022	7101293	Nest Bottom	16	20
16	30-0221	30-0221	Hinge, 2" x 3-1/2" SS	6	6
17	C5000104	C5000104	Flipper Support Bracket	1	1
18	C5000106	C5000106	Flipper	1	1
19	7101297	7101297	Clamp, Tubing 3/8"	6	6
20	S-8302	S-8302	Screw, MS #10-24 x 2-1/4" RHS	8	8
21	S-4322	S-4322	Cotter Pin 3/32" x 1"	3	3
22	S-7139	S-7139	Screw, MS #10-24 x 3/8" HHSWH	10	10
23	S-6151	S-6151	#10 External Tooth Washer	10	10
24	S-849	S-849	Hex Nut #10-24	10	10
N/S	S-2010	S-2010	Nylock Nut #10-24	8	8
N/S	S-7060	S-7060	3/16" Rivet Diameter, 7/16" Long Aluminium Rivets	70	70
N/S	S-7222	S-7222	3/16" Rivet Diameter, 5/16" Long Aluminium Rivets	125	150

AN199 Egg Collector Assembly

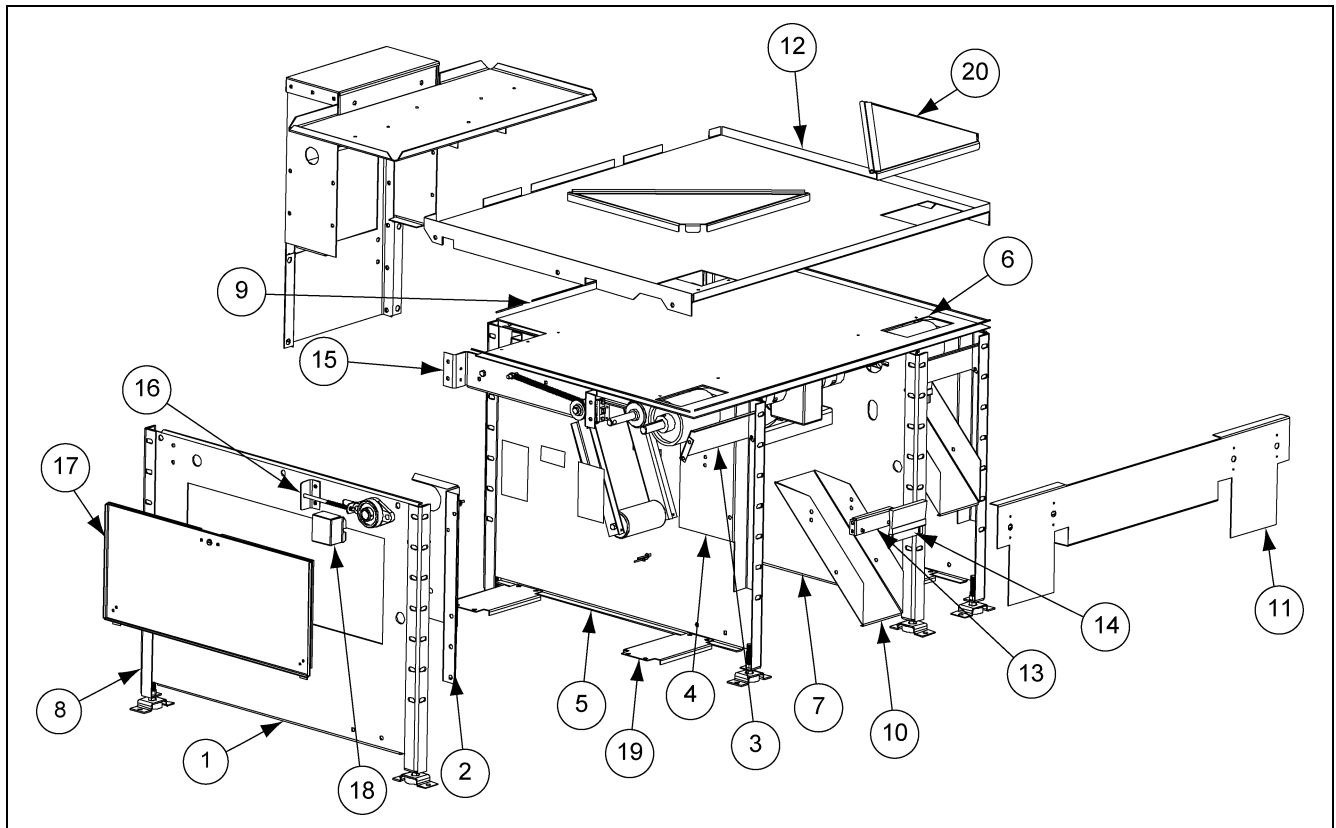

Ref #	Part #	Description	Qty
1	C5000129	Left Exterior Panel	1
2	C5000044	Left Hand Chute Support-AN199	2
3	7101326	AN199 Trash Deflector	2
4	C5000045	Right Hand Chute Support-AN199	2
5	C5000130	Left Interior Panel	1
6	C5000131	Right Exterior Panel	1
7	C5000132	Right Interior Panel	1
8	7098675	Adjustable Leg Weldment	8
9	7101432	AN199 Back Panel	1
10	7101287	AN199 Trash Chute	2
11	7101306	AN199 Front Removable Panel	1
12	7101408	AN199 Egg Table Assembly	1
13	7101410	AN199 Drive Bracket Nutsert Assembly	2
14	7101358	AN199 4-1/4" Belt Brush/Bracket Punched	2
15	7101411	AN199 Internal Drive Idler Assembly	2
16	7097767	Spring Tensioner W.A.	4
17	7099396	Side Removable Panel Assembly Front	2
18	7101603	Drive Bearing Cap	2
19	C5000035	Leg Brace	4
20	C5000123	Egg Diverter Assembly	2

Internal Drive Assembly

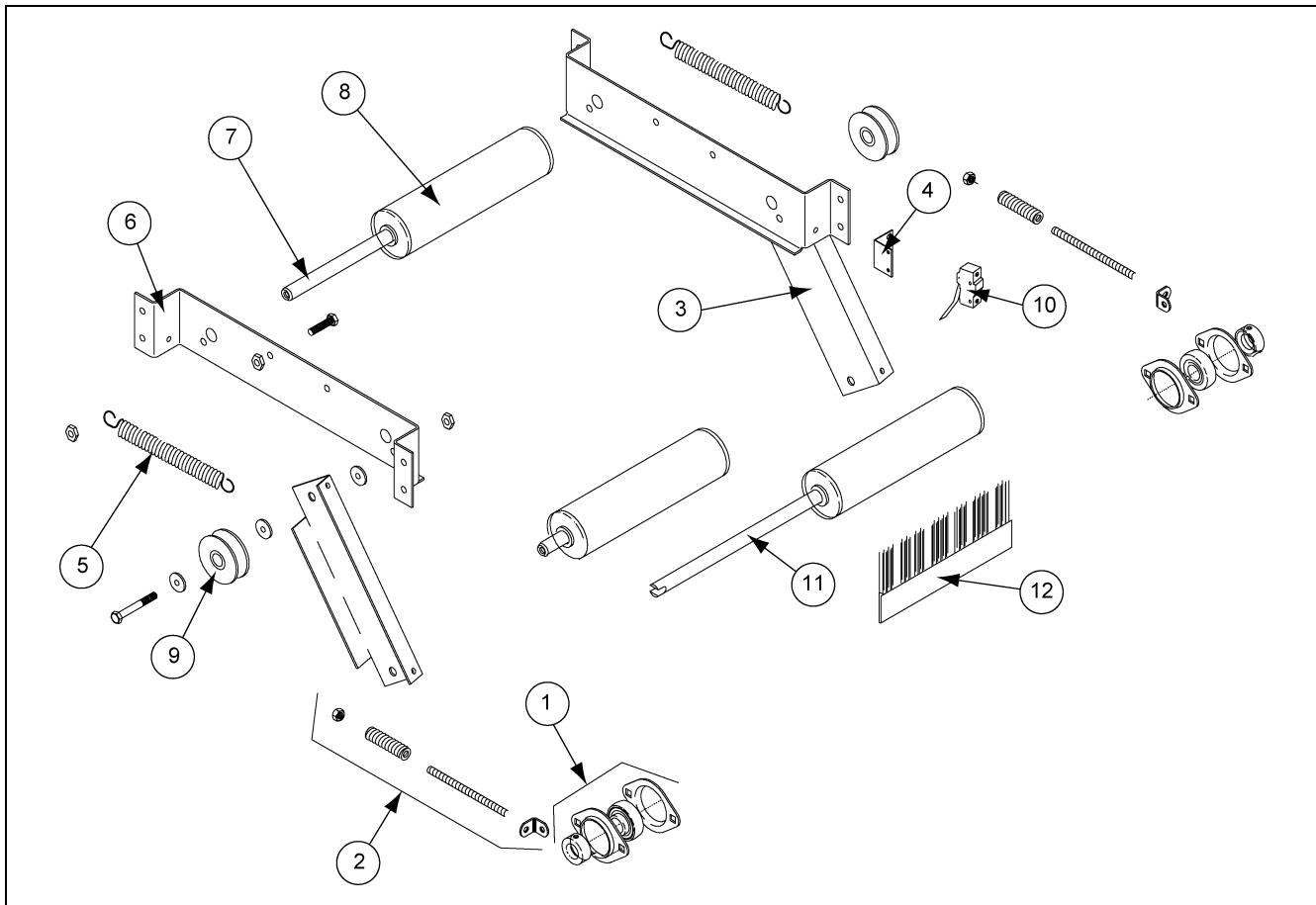

Ref #	Part #	Description	Qty
1	7097778	3/4" Bearing Assembly	4
2	7097767	Spring Tensioner W.A.	4
3	7097766	Idler Arm	4
4	7097782	Switch Mounting Bracket	2
5	7097836	Extension Spring (Idler)	4
6	7098667	Idler Roller Bracket	4
7	7101412	Internal Roller Shaft	4
8	C5000046	Belt Roller	4
9	BLK-10164	Plastic Pulley	4
10	401064	Micro Switch	2
11	7101413	Pinch Roller Shaft	2
12	7101362	Belt Brush	2

Power Unit Assembly

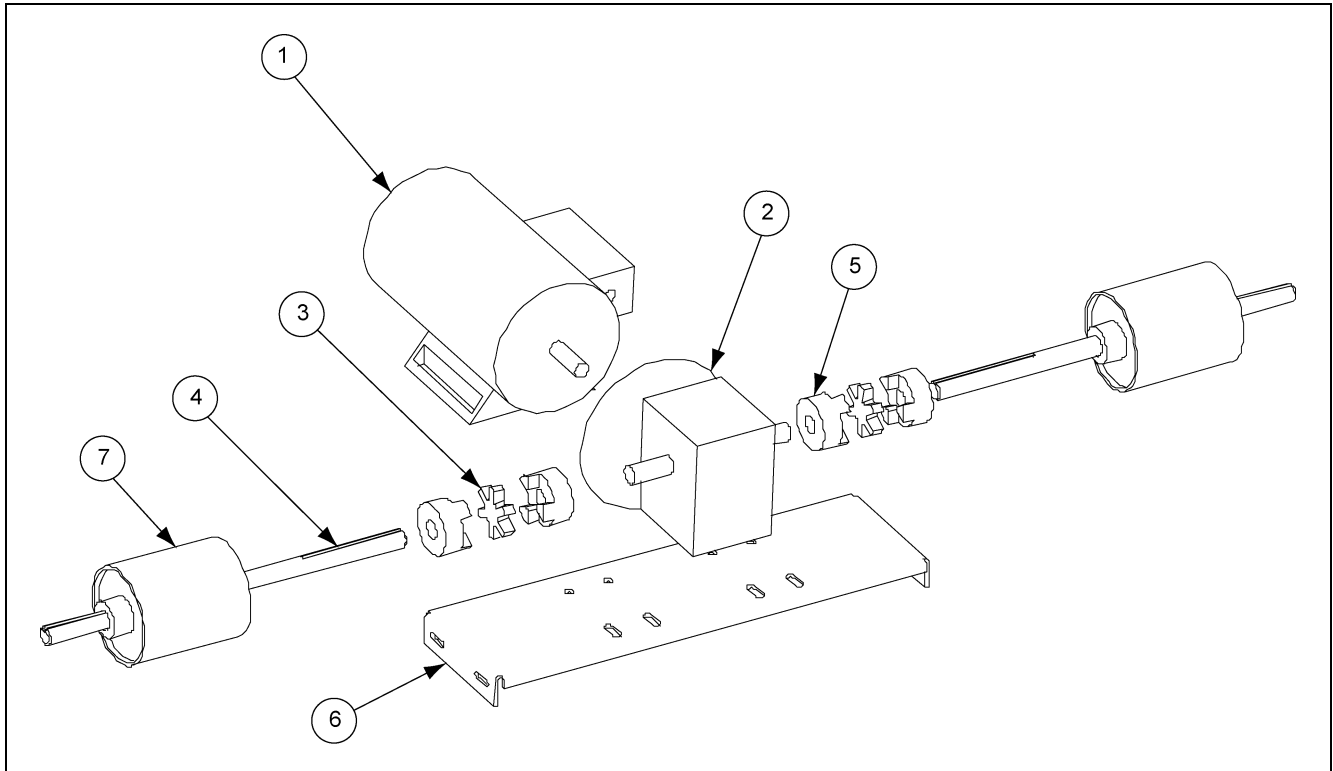

Ref #	Part #	Description	Qty
1	7097895	1/2 HP Motor	1
2	7101418	Gearbox - 40:1	1
3	52-0012	Spider Coupler	2
4	7098697	Drive Shaft	2
5	50-0008	3/4" Shaft Coupler	4
6	7101274	Motor Mount Bracket	1
7	7101415	Drive Roller Assembly	2

Return Idler Assembly

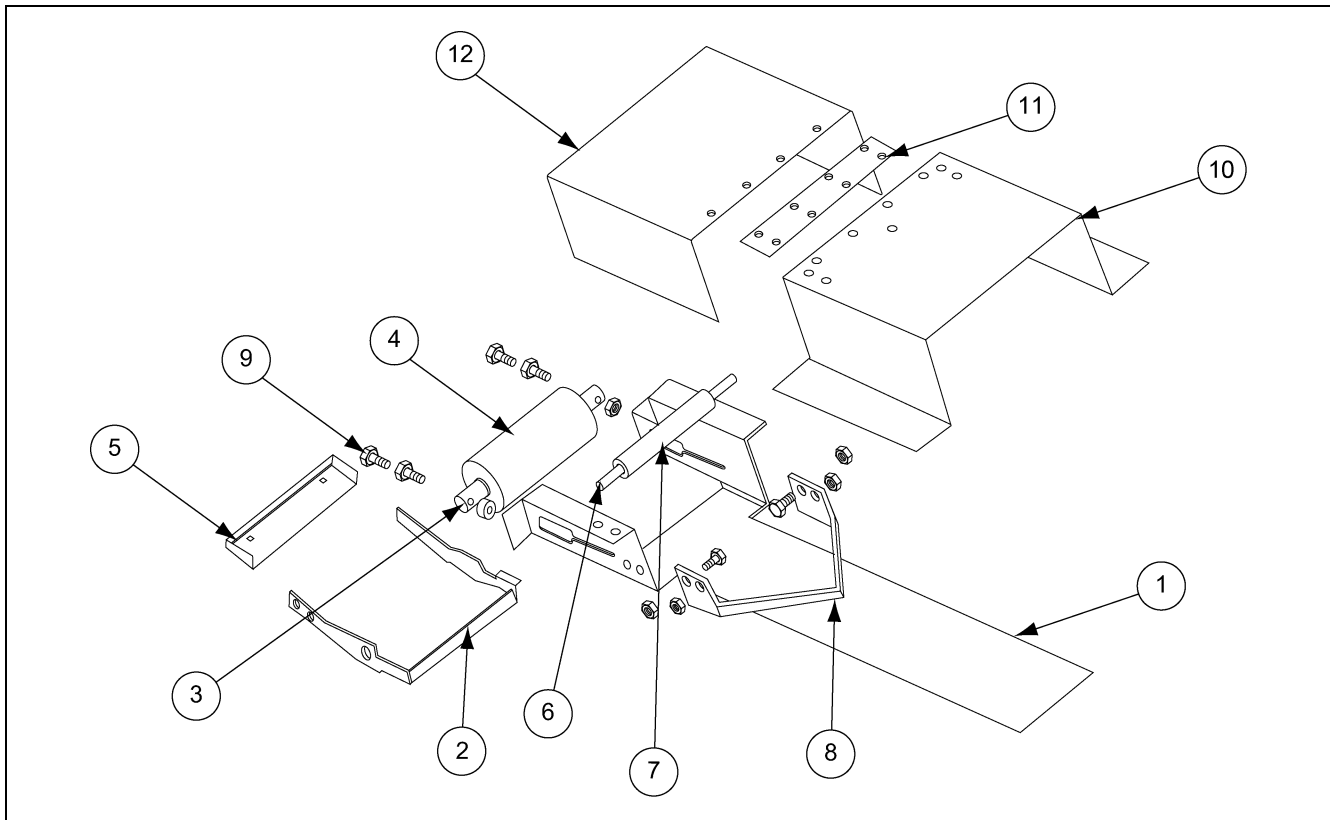

Ref #	Part #	Description	Qty
1	7101284	Roller Plate	1
2	7101301	Brush Bracket Support	1
3	7101312	End Roll Axle	1
4	C5000046	Belt Roller (AN199)	1
5	7101311	Brush Bracket	1
6	7101304	Idler Rod	1
7	7101339	Idler Roller	1
8	7101283	V-Scraper	1
9	S-7086	Bolt 5/16"-18 x 3"	2
10	7101299	Hood Back	1
11	7099615	Hinge	1
12	7101300	Hood Lid	1
N/S	7101358	Brush and Bracket	1
N/S	DC-887	Decal, Belt Direction	1
N/S	S-396	Nut 5/16"-18	8
N/S	S-4303	Bolt 5/16"-18 x 3/4"	2
N/S	S-7499	Thumb Screw #10-32	2
N/S	S-7500	Lock Washer #10	2

NOTES

GSI Group, LLC Limited Warranty

The GSI Group, LLC ("GSI") warrants products which it manufactures to be free of defects in materials and workmanship under normal usage and conditions for a period of 12 months after sale to the original end-user or if a foreign sale, 14 months from arrival at port of discharge, whichever is earlier. The end-user's sole remedy (and GSI's only obligation) is to repair or replace, at GSI's option and expense, products that in GSI's judgment, contain a material defect in materials or workmanship. Expenses incurred by or on behalf of the end-user without prior written authorization from the GSI Warranty Group shall be the sole responsibility of the end-user.

Warranty Extensions:

The Limited Warranty period is extended for the following products:

	Product	Warranty Period	
AP Fans and Flooring	Performer Series Direct Drive Fan Motor	3 Years	* Warranty prorated from list price: 0 to 3 years - no cost to end-user 3 to 5 years - end-user pays 25% 5 to 7 years - end-user pays 50% 7 to 10 years - end-user pays 75%
	All Fiberglass Housings	Lifetime	
	All Fiberglass Propellers	Lifetime	
Cumberland Feeding/Watering Systems	Feeder System Pan Assemblies	5 Years **	** Warranty prorated from list price: 0 to 3 years - no cost to end-user 3 to 5 years - end-user pays 50%
	Feed Tubes (1-3/4" and 2.00")	10 Years *	
	Centerless Augers	10 Years *	
	Watering Nipples	10 Years *	
Grain Systems	Grain Bin Structural Design	5 Years	
Grain Systems Farm Fans Zimmerman	Portable and Tower Dryers	2 Years	† Motors, burner components and moving parts not included. Portable dryer screens included. Tower dryer screens not included.
	Portable and Tower Dryer Frames and Internal Infrastructure †	5 Years	

GSI further warrants that the portable and tower dryer frame and basket, excluding all auger and auger drive components, shall be free from defects in materials for a period of time beginning on the twelfth (12th) month from the date of purchase and continuing until the sixtieth (60th) month from the date of purchase (extended warranty period). During the extended warranty period, GSI will replace the frame or basket components that prove to be defective under normal conditions of use without charge, excluding the labor, transportation, and/or shipping costs incurred in the performance of this extended warranty.

Conditions and Limitations:

THERE ARE NO WARRANTIES THAT EXTEND BEYOND THE LIMITED WARRANTY DESCRIPTION SET FORTH ABOVE. SPECIFICALLY, GSI MAKES NO FURTHER WARRANTY OF ANY KIND, EXPRESS OR IMPLIED, INCLUDING, WITHOUT LIMITATION, WARRANTIES OF MERCHANTABILITY OR FITNESS FOR A PARTICULAR PURPOSE OR USE IN CONNECTION WITH: (I) PRODUCT MANUFACTURED OR SOLD BY GSI OR (II) ANY ADVICE, INSTRUCTION, RECOMMENDATION OR SUGGESTION PROVIDED BY AN AGENT, REPRESENTATIVE OR EMPLOYEE OF GSI REGARDING OR RELATED TO THE CONFIGURATION, INSTALLATION, LAYOUT, SUITABILITY FOR A PARTICULAR PURPOSE, OR DESIGN OF SUCH PRODUCTS.

GSI shall not be liable for any direct, indirect, incidental or consequential damages, including, without limitation, loss of anticipated profits or benefits. The sole and exclusive remedy is set forth in the Limited Warranty, which shall not exceed the amount paid for the product purchased. This warranty is not transferable and applies only to the original end-user. GSI shall have no obligation or responsibility for any representations or warranties made by or on behalf of any dealer, agent or distributor.

GSI assumes no responsibility for claims resulting from construction defects or unauthorized modifications to products which it manufactured. Modifications to products not specifically delineated in the manual accompanying the equipment at initial sale will void the Limited Warranty.

This Limited Warranty shall not extend to products or parts which have been damaged by negligent use, misuse, alteration, accident or which have been improperly/inadequately maintained. This Limited Warranty extends solely to products manufactured by GSI.

Prior to installation, the end-user has the responsibility to comply with federal, state and local codes which apply to the location and installation of products manufactured or sold by GSI.

This equipment shall be installed in accordance with the current installation codes and applicable regulations which should be carefully followed in all cases. Authorities having jurisdiction should be consulted before installations are made.



**1004 E. Illinois St.
Assumption, IL 62510-0020
Phone: 1-217-226-4421
Fax: 1-217-226-4420
www.gsiag.com**