



PURAFIRE RADIANT BROODER-EZ

— PILOT IGNITION —

MODELS:

HW ZONE EZ (Zone Control)

SIT MOD EZ (Modulating)

SIT NON MOD EZ (Non-Modulating)

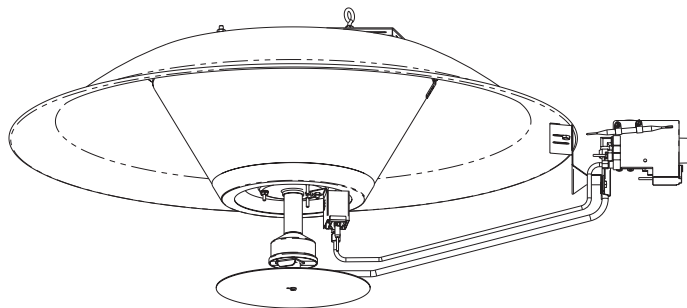

INSTALLATION AND OPERATION INSTRUCTIONS

OWNER/INSTALLER: For your safety this manual must be carefully read before installing, operating or servicing this brooder. This brooder is intended for use with either Natural Gas or Propane Gas. It must be installed by a qualified service person or a licensed contractor in accordance with state and local codes. In the absence of these codes, the installation must conform to the National Fuel Gas Code ANSI Z223.1 (latest edition) also know a NFPA54 or the CAN/CGA-B149.1/2 Installation Code in Canada.

▲WARNING: Improper installation, adjustment, alteration, service or maintenance can cause injury, property damage or death. Refer to this manual. For assistance or additional information, consult a qualified installer, service agency or the gas supplier.

INSPECT all combustion air openings into the building and, if necessary, clear as they become blocked by litter, dust, feathers or other matter.

INSPECT and clean the brooder filters on a regular basis to allow proper brooder operation.

FOR YOUR SAFETY: EXHAUST FANS **MUST** be operating on an appropriate cycle when brooders are operating to avoid a high concentration of carbon monoxide. When used without fresh air, this brooder may give off carbon monoxide, an odorless and poisonous gas. **CARBON MONOXIDE POISONING MAY LEAD TO DEATH.** Early signs of carbon monoxide poisoning resemble the flu with headaches, dizziness and nausea. If you experience these signs, **GET FRESH AIR IMMEDIATELY!** Have the brooders serviced as soon as possible and check the ventilation in the house.

These brooders are designed for agricultural applications and may operate with the use of either Natural Gas or Liquid Propane (LP) Gas. Check the brooder's nameplate to determine the correct gas type before proceeding with installation.

IF YOU SMELL GAS:

- ! **DO NOT** try to light any appliance.
- ! **DO NOT** touch any electrical switch; do not use any telephone in your building.
- ! **IMMEDIATELY** call your gas supplier from a neighbor's telephone. Follow the gas supplier's instructions. If you cannot reach your gas supplier, call the fire department.

FOR YOUR SAFETY

DO NOT store or use gasoline or other flammable vapors and liquids in the vicinity of this or any other appliance.

**SAVE THIS MANUAL
FOR FUTURE REFERENCE.**

TABLE OF CONTENTS

<u>Section</u>	<u>Description</u>	<u>Page</u>
1)	GENERAL INFORMATION	1
2)	BROODER SPECIFICATIONS	2
3)	BROODER CONTROL OPTIONS	2
4)	BROODER ASSEMBLY	3
5)	MINIMUM CLEARANCES TO COMBUSTIBLES	7
6)	BROODER INSTALLATION.....	8
7)	GAS CONNECTIONS	9
8)	ELECTRICAL CONNECTIONS	13
9)	LIGHTING AND SHUTDOWN INSTRUCTIONS.....	15
10)	VENTILATION	16
11)	MAINTENANCE	17
12)	TROUBLESHOOTING	18
13)	REPLACEMENT PARTS GUIDE.....	19

1. GENERAL INFORMATION

This brooder is a self-contained infrared radiant brooder for agricultural locations where flammable gases or vapors are not generally present.

Installation of the brooders must be in accordance with all applicable codes shown in the instructions and/or the local codes and authorities having jurisdiction. In the absence of local codes, the brooder must be installed in accordance to the National Fuel Gas Code ANSI Z223.1/NFPA54 in the U.S. or the CAN/CGA-B149.1/2 Installation Code in Canada. Clearances to combustibles as outlined in the manual should always be observed.

Inspect all openings and filters regularly and clean as necessary. This is necessary because litter, dust feathers and other matter can become airborne and clog openings and filters and adversely affect brooder operation and performance.

Every brooder should be located with respect to building construction and other equipment so as to permit access to the brooders. Each installer shall use skillful and reliable installation practices when locating the brooders and must give consideration to service accessibility.

This brooder is for **INDOOR INSTALLATION ONLY** and is used in an **UNVENTED** mode. The term *Unvented* actually means *Indirect Vented*. While the products of combustion are expelled into the building, national codes require ventilation in the building to dilute these products of combustion. This ventilation must be provided by gravity or mechanical means. Ventilation requirements are addressed further in these instructions.

This heater complies with **IAS U.S. No. 8-94 (Draft No. 2)** and **CAN-1-2-20-M85**. Copies of the National Fuel Gas Code (ANSI Z223.1-latest edition) are available from the CSA at 8501 E. Pleasant Valley Rd., Cleveland, OH 44131 or 55 Scarsdale Road, Don Mills, Ontario M3B 2R3. All NFPA codes are available from the National Fire Protection Association, Batterymarch Park, Quincy, MA 02269.

2. BROODER SPECIFICATIONS

INPUT RATING	<i>Propane Gas:</i>	40,000 Btu/hr (11.72 Kw)
	<i>Natural Gas:</i>	40,000 Btu/hr (11.72 Kw)
	<i>Propane/Butane Mix Gas</i>	40,000 Btu/hr (11.72 Kw)
GAS SUPPLY PRESSURE	<i>Propane Gas:</i>	11" - 14" W.C. (27.4 - 34.8 mbar)
	<i>Natural Gas:</i>	5" - 14" W.C. (12.4 - 34.8 mbar)
	<i>Propane/Butane Mix Gas</i>	11" - 14" W.C. (27.4 - 34.8 mbar)
MANIFOLD PRESSURE	<i>Propane Gas:</i>	10" W.C. (24.9 mbar)
	<i>Natural Gas:</i>	4" W.C. (10.0 mbar)
	<i>Propane/Butane Mix Gas</i>	10" W.C. (24.9 mbar)
ORIFICE SIZE	<i>Propane Gas:</i>	1.8mm (.0709")
	<i>Natural Gas:</i>	#33 (.1130")
	<i>Propane/Butane Mix Gas</i>	#50 (.0700")
MOUNTING HEIGHT		60" - 72" (1520mm - 1830mm)
BROODER SPACING		25' - 40' (7.6m - 12.2m)
BROODER SIZE	<i>Canopy Diameter:</i>	35" (890mm)
	<i>Brooder Height:</i>	18" (460mm)
WEIGHT*		27 lbs (12 kg)
VENTILATION REQUIRED	<i>Per Brooder:</i>	200 CFM (340 m ³ /hr)
GAS CONSUMPTION	<i>Propane Gas:</i>	0.43 GPH (1.63 L/hr)
	<i>Natural Gas:</i>	0.40 Therm (42.2 MJ/Hr)
	<i>Propane/Butane Mix Gas</i>	0.43 GPH (1.63 L/Hr)
ELECTRICAL SUPPLY		24 VAC, 1 Ph, 60Hz, 0.5A

* with Galvanized Canopy

3. BROODER CONTROL OPTIONS

HW ZONE EZ (ZONE CONTROL)

- For single or multi-zone installations using central or multiple thermostats. This 24-volt, AC, zone-type control also can operate on DC voltage as a back up. The gas valve includes a built-in regulator. A 24-volt power supply is required. Brooder can be operated by a 24-volt thermostat, computer or an environmental controller. 100% gas safety shut-off valve.

SIT MOD EZ (MODULATING THERMOSTAT)

- A modulating type HI/LO control with integral thermostat. No electrical supply is needed. Upon call for heat, the valve will open from pilot to low fire (approximately 25,000 Btu/hr) and modulate between low and high fire (40,000 Btu/hr) as necessary to maintain desired temperature setting. As the thermostat is being satisfied, the valve will modulate down to low fire and then drop to pilot upon being satisfied. 100% gas safety shut-off valve.

SIT NON MOD EZ (NON-MODULATING OPERATION)

- An individual, non-electric, fully automatic ON/OFF control with integral thermostat which operates on millivolts generated by the pilot. No electrical supply is needed. Integral thermostat features a wide temperature range for easy adjustment. 100% gas safety shut-off valve.

4. BROODER ASSEMBLY

1. Make sure that all components are present before assembling the brooder:

Qty.	Description	Qty.	Description	Qty.	Description
(1)	Control Arm	(1)	Burner Base	(1)	Low Profile Hanging Bracket
(1)	Safety Pan	(1)	Emitter Assembly	(1)	Manifold Support Bracket & Clamp
(1)	Canopy	(1)	Fastener Kit		

The Fastener Kit contains all the nuts, bolts and washers required for brooder assembly. You will need two (2) crescent wrenches and a flat-bladed screwdriver for brooder assembly.

2. Place the Low Profile Hanging Bracket onto the Canopy as shown. Secure the bracket to the center of the Canopy with a screw, nut and washer from the Fastener Kit. Assemble the eyebolt to the hanging bracket with nuts and washers. Align the hanging bracket with the two (2) holes located at the edge of the Canopy. See Figure 1.

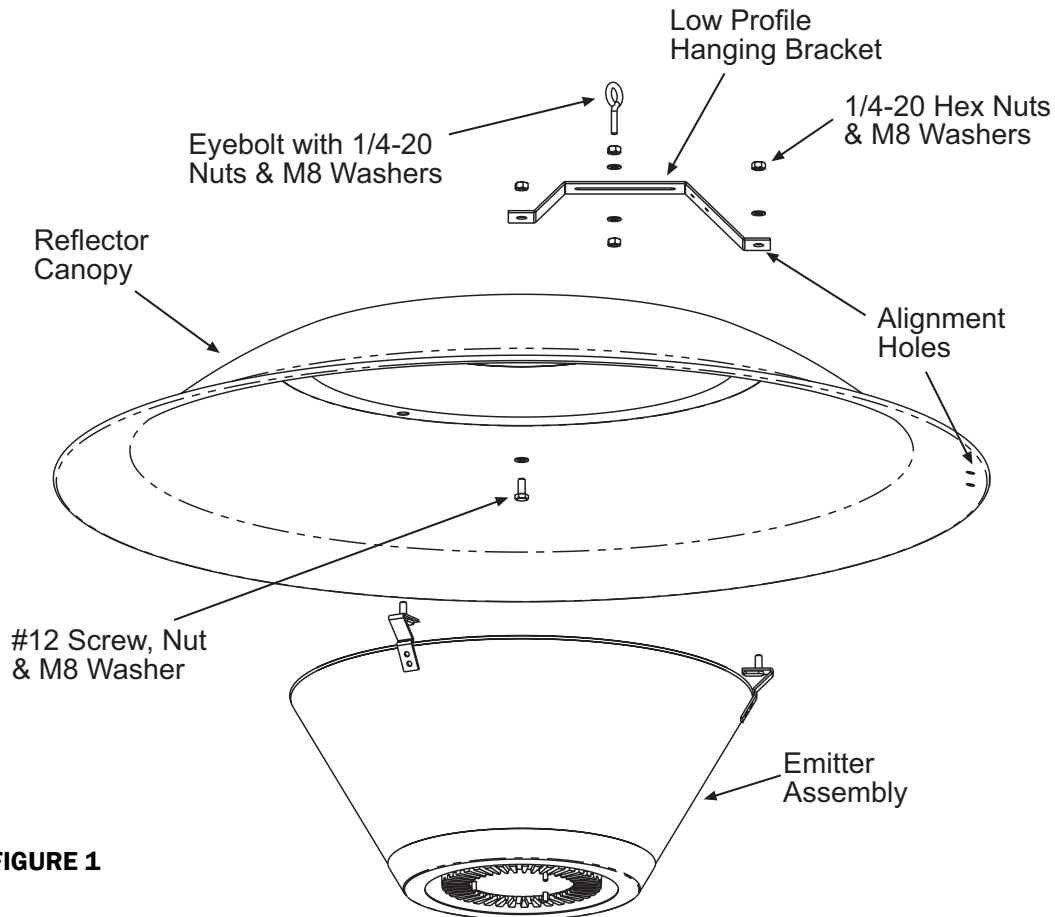

FIGURE 1

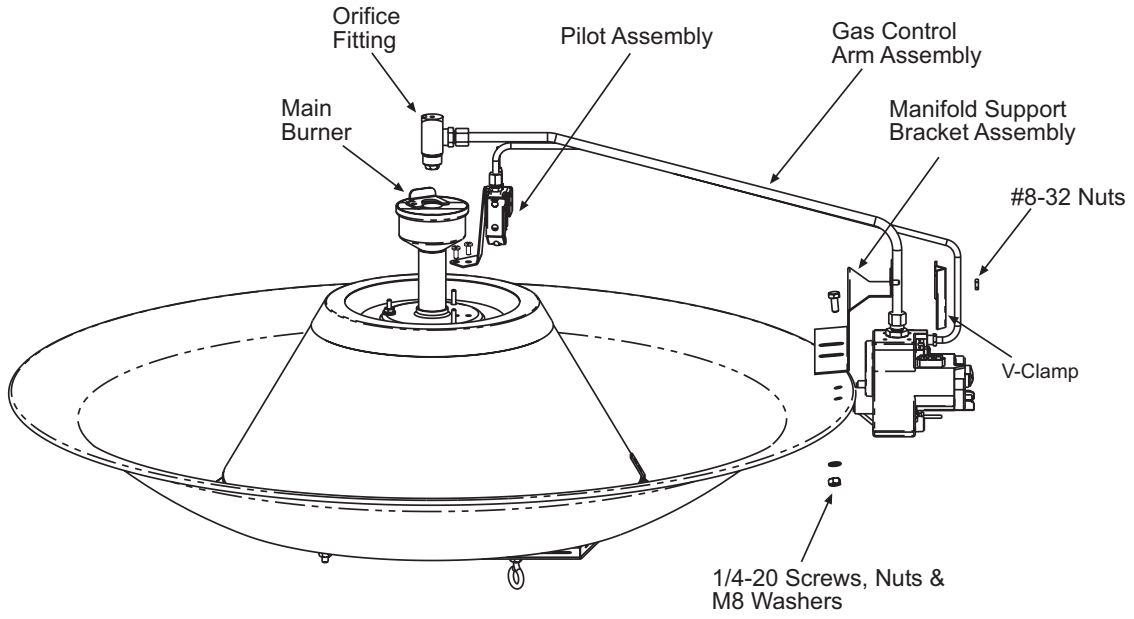

FIGURE 3

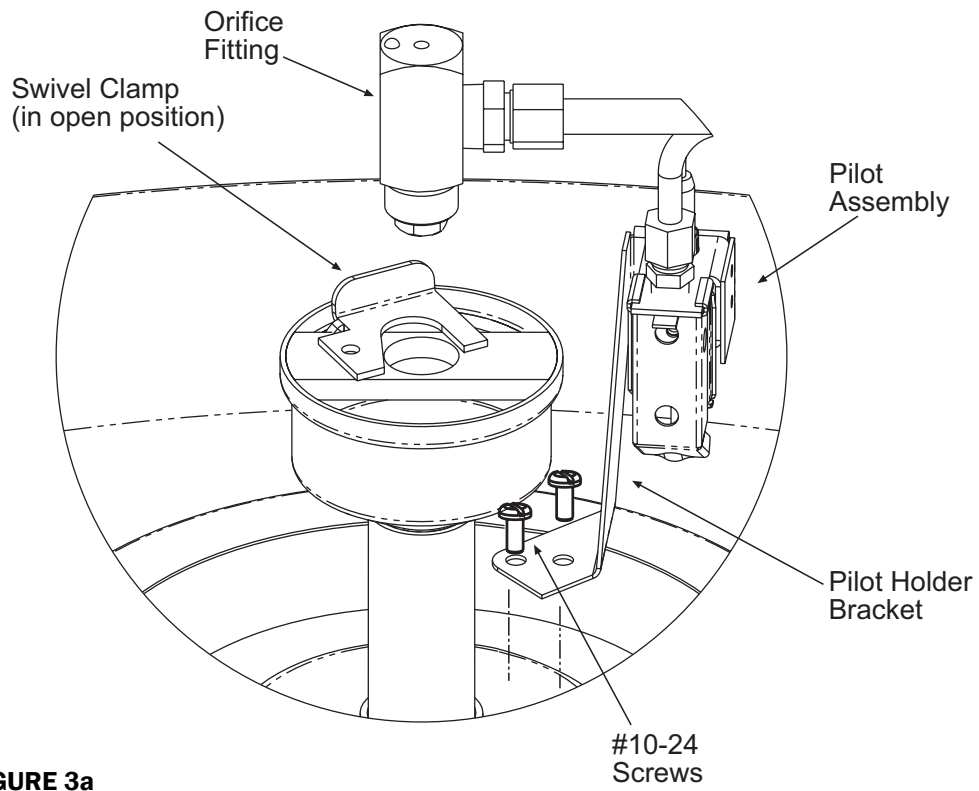
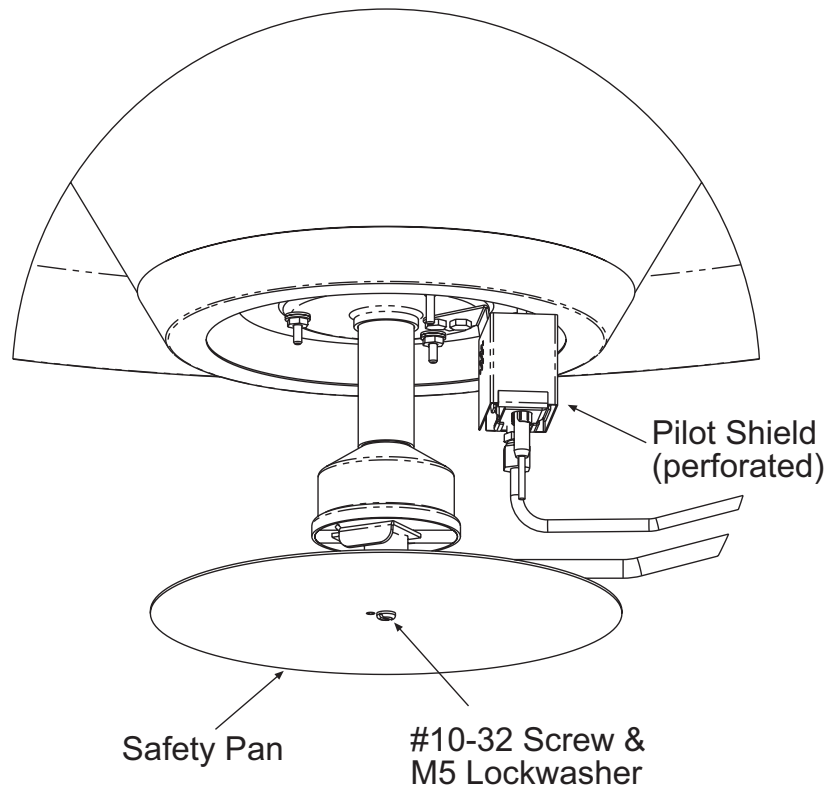

FIGURE 3a

FIGURE 3b



6. Attach the Manifold Support Bracket Assembly to the rim of the Canopy using two (2) screws, nuts and washers from the Fastener Kit. See Figure 3. **NOTE: DO NOT COMPLETELY TIGHTEN THE FASTENERS AT THIS STAGE YET.**
7. Attach the Control Arm Assembly to the Manifold Support Bracket Assembly as shown in Figure 3 using one (1) V-clamp and two (2) nuts from the Fastener Kit. **NOTE: Adjust the Control Arm so that the V-clamp is butt against the tube fitting located at the bottom of the Gas valve. Tighten the nuts.**
8. Adjust the Control Arm so that the Pilot Assembly and Orifice Fitting aligns with their connection points on the main burner. Secure the Pilot Assembly as shown in Figure 3a to the burner using two (2) screws from the Fastener Kit.
9. Insert the Orifice Fitting into the burner base as shown in Figure 3a. Rotate the swivel clamp until it locks into the groove of the Orifice Fitting.
10. Tighten the screws and nuts holding the Manifold Support Bracket Assembly installed earlier above.
11. Attach the Safety Pan to the bottom Orifice Fitting using one (1) screw and (1) spring lockwasher from the Fastener Kit. See Figure 3b.
12. Flip the brooder over to its original position and place the Pilot Shield (perforated) onto the Pilot Assembly. The brooder is now ready for installation.

▲WARNING: ONCE THE BROODER IS ASSEMBLED AND BEFORE IT IS FIRST FIRED, YOU MUST CHECK FOR GAS LEAKS! USE A SOAP AND WATER SOLUTION AND APPLY AT ORIFICE FITTING, PILOT ASSEMBLY, AND FIELD CONNECTION AT THE GAS VALVE.

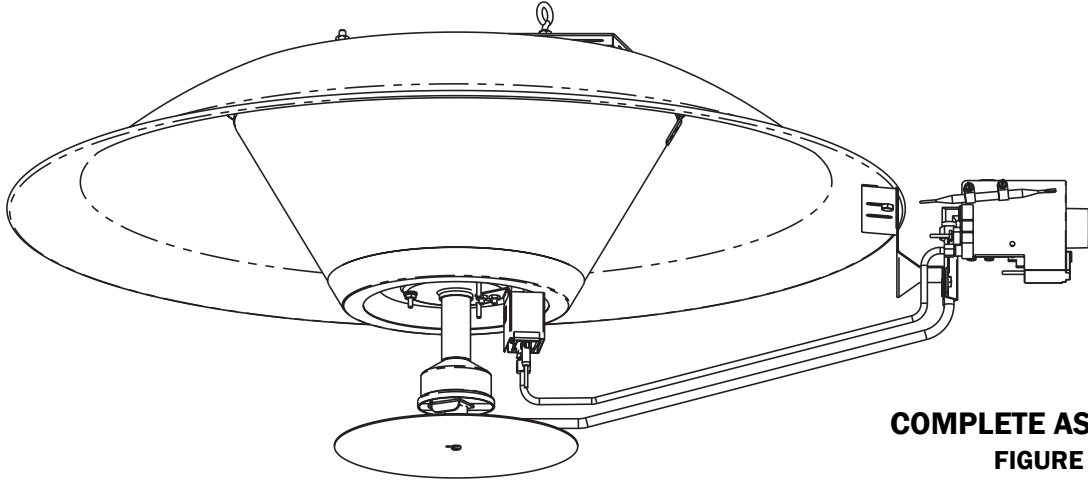

**COMPLETE ASSEMBLY
FIGURE 4**

5. MINIMUM CLEARANCES TO COMBUSTIBLES

Minimum clearances to combustible materials shall be measured from the outer surface of the canopy as shown in the following table:

MINIMUM CLEARANCES TO COMBUSTIBLES		
SIDES:	BELOW:	ABOVE:
36" (915 mm)	48" (1220 mm)	18" (460 mm)

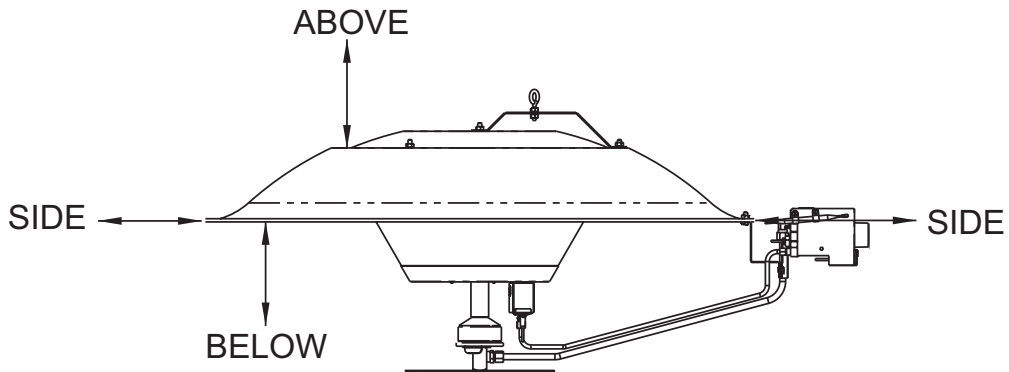

FIGURE 5

6. BROODER INSTALLATION

1. Locate brooders approximately 25' to 40' (8m to 12m) apart, in a row, as needed for bird comfort and building heat loss. If more than one row is desired, stagger rows for best heat distribution.

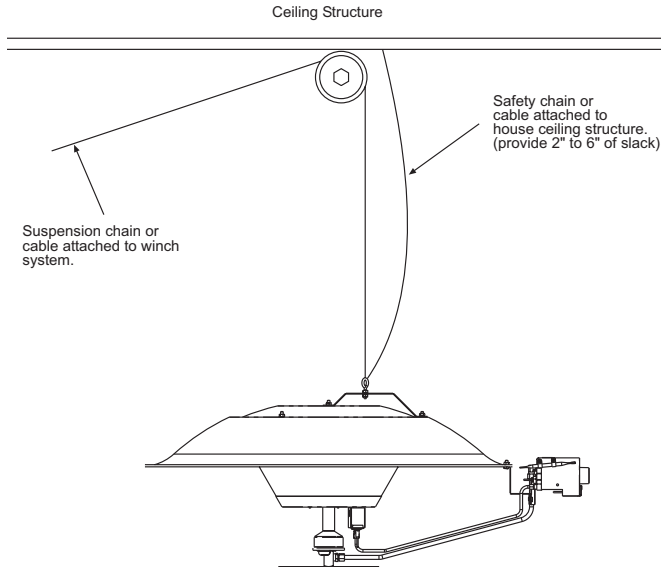



FIGURE 5a

2. Suspend the brooder at the desired height above the floor (litter) level, normally 60" to 72" (1520mm to 1830mm). For brooders connected to a winch (to allow for adjustment of brooder height), connect each brooder using a chain or cable suitable for the weight of each brooder. **DO NOT USE ROPE.** Size the winch and cable so that it is capable of handling the total weight of all brooders and gas piping involved. **NOTE: Connect a safety chain to each brooder and anchor it to the house structure above each brooder to prevent it from falling onto the litter if the cable/chain breaks or the winch fails. THE GAS HOSE SHOULD NEVER BE USED AS A SAFETY CHAIN!**
3. Connect the gas line and electrical supply (if required) to each brooder as outlined in Sections 7 and 8.

NOTE: After connection of the gas line, make sure that the brooder is suspended with the control side approximately $\frac{1}{2}$ " (13mm) below the other side of the brooder to prevent hot products of combustion from damaging the gas control valve.

! WARNING	
	<u>FIRE HAZARD</u>
	A safety chain must be connected from the hanging bracket to a fixed part of the building structure directly above the brooder.
	The safety chain will prevent the brooder from falling to the floor in the event that the main suspension system fails
Failure to follow these instructions may result in death, serious injury or property damage	

7. GAS CONNECTIONS

1. Gas piping for the house must be sized to be capable of satisfying the entire demands of the house should all equipment be operating at the same time. Please use Table 1 (taken from the National Fuel Gas Code) for the sizing of piping for the house. An example using this table is shown.
2. Connect to the supply tank or manifold in accordance with the latest edition of the National Fuel Gas Code (ANSI Z223.1) and/or local codes. Authorities having jurisdiction should be consulted before the installation is made. Refer to the latest edition of CAN/CGA B.149-1/2 Installation Codes for Gas Burning Appliances and Equipment in Canada.
3. Pipe joint compounds must be resistant to the action of liquefied petroleum (LP) gases.

4. Gas connections to individual brooders can be made in several ways to fit individual operation practices. Brooders can be "hard-piped," or they can utilize flexible gas connectors, or they can utilize rubber hosing suitable for LP gas usage (to allow movement of the brooders for cleaning, etc.). Check with the authorities having jurisdiction and/or local codes prior to choosing an individual gas connection method. For connection to tubing, a 1/2"MPT x 3/8" barbed fitting for the -2 control model (Part No. 03442000) or a 3/8"MPT x 3/8" barbed fitting for the -3 and -9 control models (Part No. 0326800) is available as an accessory.

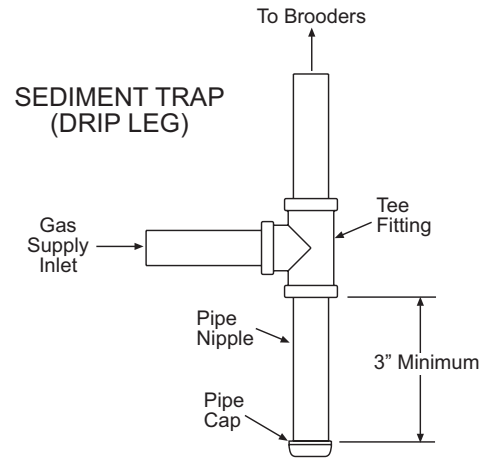

FIGURE 5b

5. It is strongly recommended that a field installed manual shut-off valve be installed in the gas piping to each brooder. This will allow service of individual brooders without having to shut down the entire gas supply system. When installing the gas line, it is recommended to connect a sediment trap (see illustration, previous page) in the gas line at a point before the gas line enters the house. This trap or "drip leg" acts to trap impurities and water that can condense out of the gas. It helps to keep impurities from entering the appliance and causing potential damage to gas valves, etc. Periodically remove the cap from the drip leg and drain any accumulation of dirt and/or water.
6. After all gas connections and adjustments are made, check all gas connections for leaks (not just the gas connections at the brooders) using a heavy soap suds solution or by using one of the methods listed in Appendix D of the National Fuel Gas Code. **▲WARNING: DO NOT USE AN OPEN FLAME OF ANY KIND TO TEST FOR LEAKS!**
7. It is recommended that a pressure gauge be installed at the end of the gas piping run to allow you to check the gas supply pressure in the system. This needs to be capable of accurately measuring in units of inches of water column or mbar.

7a. INSTRUCTIONS FOR TESTING FOR GAS LEAKS AND PROPER GAS PRESSURE

▲WARNING: DO NOT OMIT THESE TESTS!

TESTING THE INSTALLATION FOR GAS LEAKS:

1. Inspect all connections and appliance valves to be sure connections are wrench-tight and that all appliance valves are closed, including the pilot valves.
2. Connect a low-pressure test set to the low pressure piping system just upstream of the appliance regulators and control. **NOTE:** A dry gauge manometer is available as an accessory (Part No. 43649000).
3. Fully open the LP gas container valve slowly to pressurize the piping system. Once the system is pressurized and stabilized, close the container valve tightly.
4. Observe the indicated pressure on the low-pressure test set gauge. This reading should be approximately equivalent to the set delivery pressure of the final stage regulator. Now, slowly open one burner valve or pilot valve on the appliance to vent off just enough gas to reduce the pressure on the test gauge by 1" water column, then close the burner or pilot valve.

If the pressure remains unchanged on the gauge for at least 10 minutes, the system can be assumed leak-tight. If a drop in pressure does occur, it indicates a leak in the system.

If the pressure drop occurs, check the joints, connectors, and other possible points of leakage with an approved, high quality leak detection solution. **NEVER USE A MATCH OR OPEN FLAME TO CHECK FOR LEAKS.** Once a leak has been located and repaired, repeat Steps 3 and 4 above. If there is an increase in pressure, it indicates that the LP gas container valve is not shut off tightly. Shut off the valve tightly and repeat Step 4 above.

NOTE: Do not expose final stage piping to excessive heat or direct sunshine during the leak test. Pressure build-up in the line due to heat may compensate for pressure loss due to leaks. This will prevent the gauge reading from indicating system leaks.

▲WARNING: Gas Pressure Testing is to be performed only by qualified personnel.

CHECK GAS INLET (SUPPLY) PRESSURE:

1. Be sure the valve is in the "OFF" position before removing the pressure tap plug at the valve. Connect a low-pressure test set (water manometer or dry gauge) to the 1/8" NPT Inlet Pressure Tap connection. (Refer to Figure 6 for each control valve type.) Turn the valve to the "ON" position. **DO NOT EXCEED THE PRESSURES SHOWN IN THE GAS PRESSURE TABLE.**
2. Turn the valve back to the "OFF" position before removing the test set and replacing the plug. Repeat the gas leak test at the plug.

CHECK GAS OUTLET (MANIFOLD) PRESSURE:

1. Be sure that the valve is in the "OFF" position before removing the pressure tap plug at the valve. With the main burner operating, check the manifold pressure using a lower-pressure test set connected to the 1/8" NPT Outlet Pressure Tap. (Refer to Figure 6 or 6a for each control valve type.) The HW ZONE EZ has combination valves with built-in appliance regulators. These regulators are factory set and should not require adjustment. They should provide the correct manifold pressure at the varying supply pressures noted in the Gas Pressure Table below. **DO NOT EXCEED THE PRESSURES SHOWN IN THE GAS PRESSURE TABLE.**

**FIGURE 6
HW ZONE EZ**

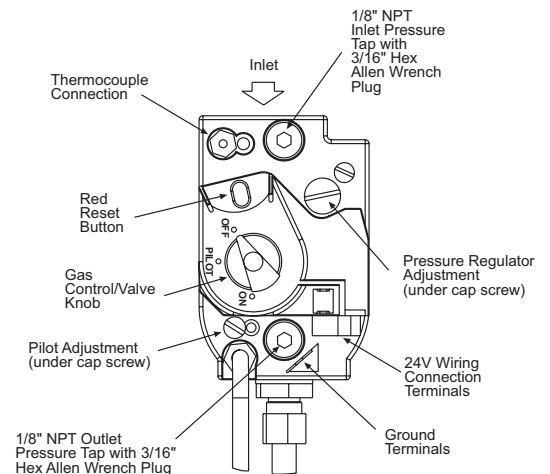

- If manifold gas pressure adjustment is required, remove the cover screw. (See Figure 6 or 6a for valve drawings.) Using a small screwdriver, turn the adjusting screw clockwise \curvearrowright to increase or counter clockwise \curvearrowleft to decrease the gas pressure to the burner.
- Turn the valve back to the "OFF" position before removing the manometer and replacing the plug. Repeat the gas leak test at the plug.

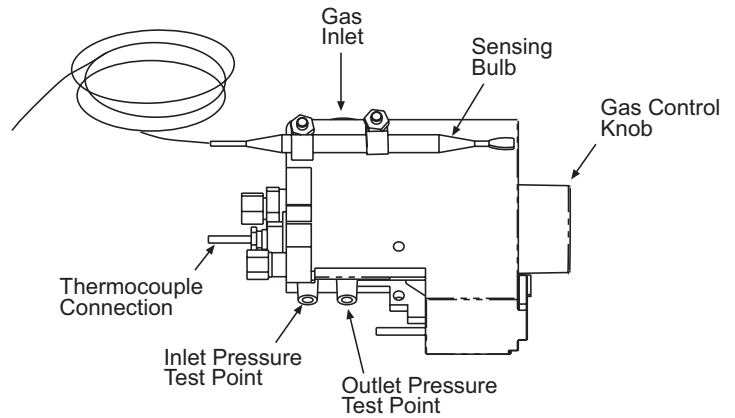

FIGURE 6a
SIT MOD EZ & SIT NON MOD EZ

GAS PRESSURE TABLE				
BROODER MODEL	GAS TYPE	MANIFOLD PRESSURE	SUPPLY PRESSURE	
			<i>Minimum</i> ♦	<i>Maximum</i>
HW ZONE EZ	Natural Gas	4" WC (10.0 mbar)	5" WC (12.4 mbar)	14" WC (34.9 mbar)
SIT MOD EZ & SIT NON MOD EZ	Natural Gas	4" WC (10.0 mbar)	4.5" WC (11.4 mbar)	5.5" WC (14.0 mbar)
ALL	Propane Gas	10" WC (24.9 mbar)	11" WC (27.4 mbar)	14" WC (34.9 mbar)
ALL	Propane/Butane Mix Gas	10" WC (24.9 mbar)	11" WC (27.4 mbar)	14" WC (34.9 mbar)

♦ Minimum permissible gas supply pressure for the purpose of input adjustment.

PRESSURE READING NOTES — SIT MOD EZ & SIT NON MOD EZ CONTROLS ONLY:

- INLET PRESSURE can be checked by turning the captured screw (see Figure 6a) counter clockwise \curvearrowleft 2 or 3 turns and then placing the tubing from the gauge over the test point.
- OUTLET PRESSURE can be checked in the same manner as described above by using the captured screw.

▲WARNING: After taking pressure readings, be sure to turn captured screws clockwise \curvearrowright firmly to reseal. Do not over torque. The appliance regulator is not adjustable.

REGULATOR LOCK-UP AND LEAKAGE:

After the leak testing and delivery pressure tests have proven satisfactory, the regulator lock-up and leakage test may be performed. The lock-up pressure of the final stage regulator should be slightly higher than, but not more than, 120% of the set delivery pressure. For example, on a delivery pressure setting of 12" water column, the maximum allowable lock-up pressure is 14.4" water column.

To perform the lock-up and leakage test, follow these steps:

- With the LP tank valve fully open, shut off all appliance valves so there is no demand for gas. This includes shutting off all pilots.
- A slight rise in pressure will occur under these conditions. This rise should be no more than 120% of the delivery pressure. This is the lock up pressure. **NOTE:** A quick rise in pressure above the allowable lock-up point could indicate undersized piping, a worn seat disc or foreign material in the seating area. **This condition must be corrected before putting the system in service.**
- Continue the test for five minutes or more. If a creeping rise in pressure is noticed, the final stage regulator seat is not closing off properly. The regulator must be replaced or repaired, and the system retested, before putting the system in service.

7b. GAS PIPE SIZING EXAMPLE

House Size: 40' x 400'

Brooder Quantity: 14

Individual Brooder Capacity: 40,000 Btu/hr

Second Stage Regulator Pressure: 14" W.C.

Operating Pressure: 11"W.C., LP gas with all brooders operating

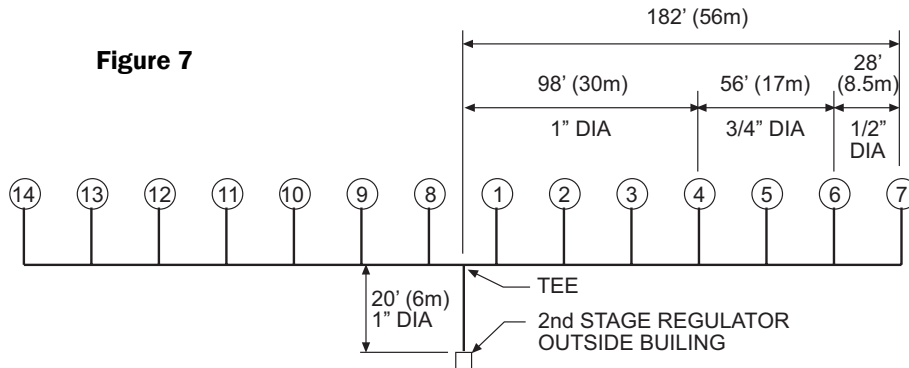

STEP 1. Gas should be run at high pressure from the LP tank to the second stage regulator at the house. Using the above house configuration example, calculate the gas pipe sizing. First, calculate the total distance from the second stage regulator to the furthest brooder. In Figure 9 above, that distance equals 202' (20' + 182'). Using Table 1, look up the row for 200' and select the smallest pipe size that has the capacity for the flow of the end brooder (40,000). The smallest pipe size is ½" with a capacity of up to 58,000 Btu/hr over 200'.

STEP 2. Calculate the distance from the second furthest brooder to the secondary regulator. In the example, that distance equals 174'. Using Table 1, look up the row for 174'. As 174' is not listed, you will use the next distance up, in this case, 200'. Then select the smallest pipe size that has the capacity for the flow of both the furthest (#7) and second furthest (#6) brooders, which combines to 80,000 Btu/hr. The smallest pipe size is ¾" with a capacity of up to 120,000 Btu/hr over 200'. Repeat this process for each brooder until you reach the Tee. Table 2 shows the completed example.

STEP 3. At the Tee, calculate the total distance to the secondary regulator. In this example, that equals 20'. Using Table 1, look up the row for 20' and select the smallest pipe size that has the capacity for the flow of all the brooders connected to the pipe system (560,000). The smallest pipe size is 1" with a capacity of up to 788,000 Btu/hr over 20'.

TABLE 1. – LP Gas Pipe Sizing Between Single or Second Stage Regulator and Brooders Per ANSI Z223.1 National Fuel Gas Code-1992

	Tubing Size, O.D. Type L						Nominal Pipe Size, I.D. Schedule 40							
	3/8"	1/2"	5/8"	3/4"	7/8"	1-1/8"	1/2"	3/4"	1"	1-1/4"	1-1/2"	2"	3"	4"
10 Ft.	39	92	199	329	501	935	291	608	1,146	2,353	3,525	6,789	19,130	39,018
20 Ft.	26	62	131	216	346	630	200	418	788	1,617	2,423	4,666	13,148	26,817
30 Ft.	21	50	107	181	277	500	161	336	632	1,299	1,946	3,747	10,558	21,535
40 Ft.	19	41	90	145	233	427	137	287	541	1,111	1,665	3,207	9,036	18,431
50 Ft.	18	37	79	131	198	376	122	255	480	985	1,476	2,842	8,009	16,335
60 Ft.	16	35	72	121	187	340	110	231	435	892	1,337	2,575	7,256	14,801
80 Ft.	13	29	62	104	155	289	94	198	372	764	1,144	2,204	6,211	12,668
100 Ft.	11	26	55	90	138	255	84	175	330	677	1,014	1,954	5,504	11,227

continued, next page

(Table 1, continued)

	Tubing Size, O.D. Type L						Nominal Pipe Size, I.D. Schedule 40							
	3/8"	1/2"	5/8"	3/4"	7/8"	1-1/8"	1/2"	3/4"	1"	1-1/4"	1-1/2"	2"	3"	4"
125 Ft.	10	24	48	81	122	224	74	155	292	600	899	1,731	4,878	9,950
150 Ft.	9	21	43	72	109	202	67	141	265	544	815	1,569	4,420	9,016
200 Ft.	8	19	39	66	100	187	58	120	227	465	697	1,343	3,783	7,716
250 Ft.	8	17	36	60	93	172	51	107	201	412	618	1,190	3,353	6,839
300 Ft.	—	—	—	—	—	—	46	97	182	374	560	1,078	3,038	6,196
350 Ft.	—	—	—	—	—	—	43	89	167	344	515	992	2,795	5,701
400 Ft.	—	—	—	—	—	—	40	83	156	320	479	923	2,600	5,303

Maximum propane capacities listed are based on 1/2" W.C. pressure drop at 11" W.C. setting - Capacities in 1,000 BTU/hr.

TABLE 2.

Brooder #	Distance from Regulator (ft.)	Flow Capacity Required (Btu/hr)	Distance Used from Table (ft.)	Smallest Pipe Size and Capacity From Table
7 and 14	202	40,000	200	1/2" – 58,000
6 and 13	174	80,000	200	3/4" – 120,000
5 and 12	146	120,000	150	3/4" – 141,000
4 and 11	118	160,000	125	1" – 292,000
3 and 10	90	200,000	100	1" – 330,000
2 and 9	62	240,000	60 ^{Note 1}	1" – 435,000
1 and 8	34	280,000	40	1" – 541,000 ^{Note 2}

Note 1: The distance used is rounded down to 60.

Note 2: The actual smallest pipe size for the required capacity is 3/4" from the table. However, the gas pipe size from brooders 3 and 4 to the regulator must be 1" diameter and therefore a smaller diameter pipe cannot be used. If 3/4" pipe was used from the Tee to brooder 1, the pressure drop in the rest of the system would exceed the design pressure drop of 1/2"W.C.

8. ELECTRICAL CONNECTIONS

- All electrical wiring shall conform to the latest edition of the National Electrical Code (ANSI/ NFPA No. 70), or the code legally authorized in the locality where the installation is made.
- The electrical system must be electrically grounded in accordance with the National Electrical Code (ANSI/ NFPA No. 70-latest edition) or the Canadian Electrical Code (C22.1 Part 1-latest edition) as appropriate.
- The brooders with the SIT MOD EZ and SIT NON MOD EZ control options do not require any electrical supply because they generate their own electricity and operate thermostatically off this power. The brooders with the HW ZONE EZ control option require a 24VAC supply to each brooder. **NOTE:** If you plan to use the Zone Control Panel Model ZCP22 (available as an accessory, Part #43619060) with its DC back-up power supply capabilities, special attention must be given to individual brooder wiring because the DC electrical power is polarity sensitive. All brooders must be connected the same way (i.e., the same power leg must be connected to the same terminal on every brooder). While this will not affect brooder operation on 24VAC, brooders that are not hooked up in this manner will not work properly on DC power. Refer to Figure 8 for a typical wiring schematic. These HW ZONE EZ control brooders must be supplied with a thermostat for temperature control (either with or without the Zone Control Panel).
- The ZCP22 Zone Control comes equipped with a 375VA transformer to power up to forty HW ZONE EZ brooders.

- A Thermostat (available as an accessory, Part #30525000, or an environmental controller, etc.) is also required for each brooder or group of brooders as shown in the schematic. The schematic (Figure 8) shows a group of four (4) brooders controlled by one (1) thermostat. Additional zone groups having more or less brooders can be added. These should be wired the same as shown in the schematic. Contact the factory for pricing and availability for the Zone Control and Thermostat.

SCHEMATIC Figure 8

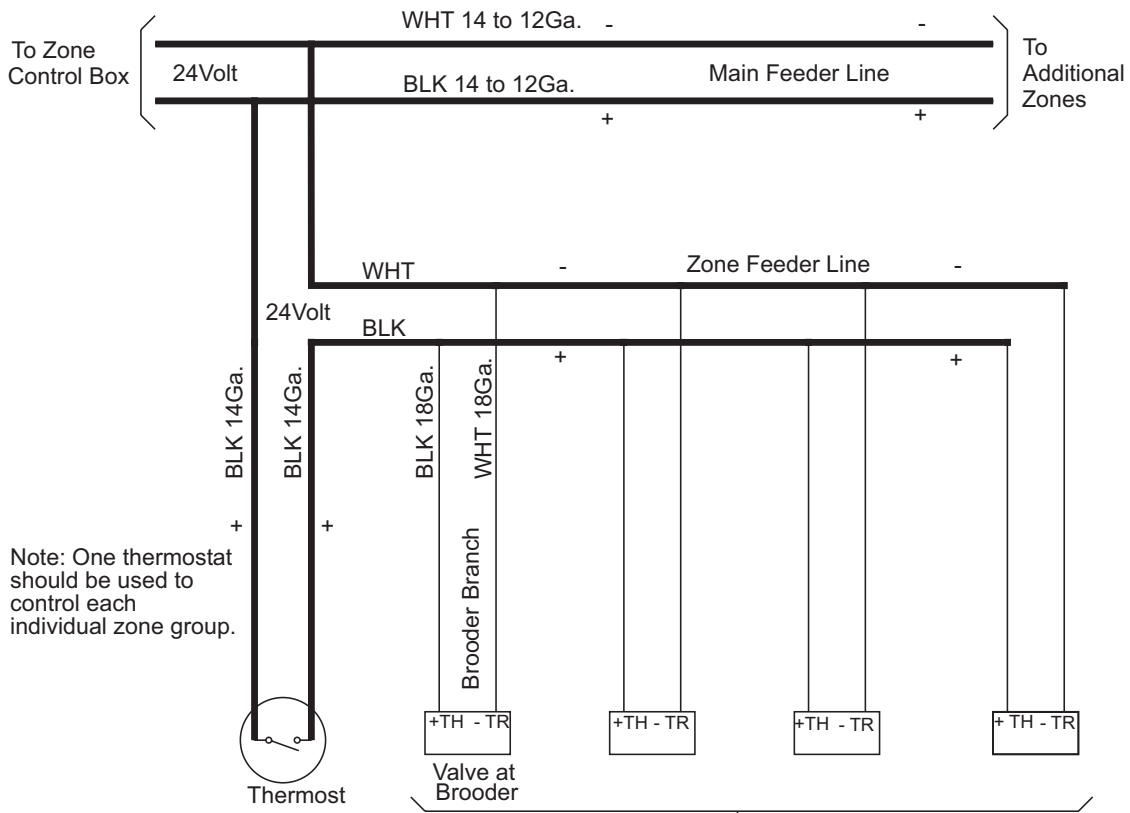

This schematic represents a group of four (4) brooders controlled by one (1) thermostat. Additional zones should be wired per this schematic to maintain correct polarity for DC operation.

9. LIGHTING AND SHUTDOWN INSTRUCTIONS

◆ HW ZONE EZ CONTROL (#VR8200M VALVE)

1. Turn gas control knob counterclockwise ∪ to "PILOT".
2. Push and hold down the red reset button while you light the pilot. Immediately light the pilot with a match. Continue to hold the control/reset button down for about one (1) minute after the pilot is lit. If it goes out, wait five (5) minutes before trying to relight the pilot. **NOTE: If the reset button does not pop up when released, stop and immediately call your service technician or gas supplier.**
3. If the pilot will not stay lit after several tries, turn the gas control knob clockwise ∪ to "OFF" and call your service technician or gas supplier.
4. When the pilot flame remains lit, turn the gas control knob counterclockwise ∪ to "ON".
5. Turn on electrical power supply to the brooder.
6. Adjust the wall-mounted thermostat to change the temperature setting. Adjust as desired for bird comfort.
7. **NOTE:** To turn off the main burner only, turn the gas control knob clockwise ∪ to "PILOT". For complete shutdown, turn the gas control knob clockwise ∪ to "OFF".

◆ SIT MOD EZ & SIT NON MOD EZ CONTROLS (#0630501 VALVE)

1. Turn the gas cock dial on the control valve to the "PILOT" position. Depress the dial and apply lighted taper to the pilot burner.
2. Hold the dial in for one (1) minute after the pilot is lit. Release the dial. If pilot flame fails to establish, repeat the procedure.
3. If pilot flame fails to establish after a second attempt, refer to the fault-finding chart.
4. When the pilot flame is established, turn the gas cock dial to the "ON" position and set the thermostat to call for heat. The main burner will ignite.
5. Adjust the remote thermostat to change the temperature setting. Adjust as desired for bird comfort.

NOTE: TO TURN OFF THE MAIN BURNER only, turn the gas cock dial to the "PILOT" position. FOR COMPLETE SHUTDOWN of main burner and pilot, press in the gas cock dial and turn to the "OFF" position.

6. If the brooder is to be taken down for inspection or maintenance, turn the ON/OFF ball valve on the connecting kit hose to the "OFF" position and disconnect the hose from the control valve inlet.

APPROXIMATE TEMPERATURE VERSUS CONTROL KNOB POSITION

Thermostat Range	CONTROL KNOB POSITION						
	1	2	3	4	5	6	7
°C	21°	26°	30°	33°	39°	43°	47°
°F	70°	79°	86°	91°	102°	109°	117°

10. VENTILATION

FOR YOUR SAFETY: Exhaust fans must be operating on an appropriate cycle when heating the building to avoid high concentrations of carbon monoxide and water vapor.

The temptation, particularly during the winter months, is to close up the poultry house to conserve heat and save money. This must be resisted, particularly during the heating up period prior to the arrival of the stock, because the lack of ventilation can restrict the required amount of combustion air for the brooders causing them to burn improperly and produce levels of carbon monoxide which could be harmful to people and the stock.

▲WARNING: Carbon Monoxide is an odorless and poisonous gas. Extended exposure to carbon monoxide may lead to death. Early signs of carbon monoxide poisoning resemble the flu, including headaches, dizziness and/or nausea. If you experience these signs, **GET FRESH AIR IMMEDIATELY**. Have the brooders serviced as soon as possible and check the ventilation in the house.

The National Fuel Gas Code requires a minimum of 4 CFM per 1000 Btu/hr of brooder input for ventilation. This requirement means that a total of 160 CFM is required per brooder. Ventilation requirements may vary depending on other equipment that may be located in the building requiring ventilation. All ventilation requirements should be addressed before sizing the necessary gravity or mechanical means to accomplish this ventilation.

While ventilation is necessary for proper brooder operation and proper growing conditions for the stock, excessive ventilation can result in high fuel consumption. Adjust the ventilation as necessary for optimum performance of the brooders and growing conditions for the stock.

11. MAINTENANCE

To keep your brooder in good operating condition, we recommend that after each crop you follow the maintenance schedule below:

!CAUTION:
**TURN THE GAS AND ELECTRIC (IF EQUIPPED) SUPPLIES OFF AND
ALLOW THE BROODER TO COOL DOWN BEFORE ATTEMPTING ANY
MAINTENANCE.**

1. Release the main burner orifice fitting and pan from the burner by turning the swivel clamp. **CAUTION:** In order to prevent damage to the control arm tubing, first place hand under the pan and allow the control to lower gently under its own weight.
2. Unscrew the main burner orifice from the orifice fitting and clean the orifice by soaking it in acetone. Dry the orifice by blowing compressed air through it. **NOTE: DO NOT attempt to clean the orifice by passing a wire through the orifice as this will increase the orifice hole and result in overfiring of the emitter.**
3. Apply pipe thread sealant (resistant to LP Gas) to the threads of the orifice and replace it into the orifice fitting. Re-connect the orifice fitting and pan to burner in reverse order.
4. Remove the pilot burner orifice and clean as described above for the main burner orifice. Access to the pilot burner can be made by first sliding the windshield off the pilot assembly. Next, remove the outer pilot housing from the pilot assembly by pulling the tab with a pair of pliers. After cleaning, reassemble the pilot in reverse order. **Note:** Make sure that the outer pilot housing snaps into place with the inner pilot housing.

Figure 9

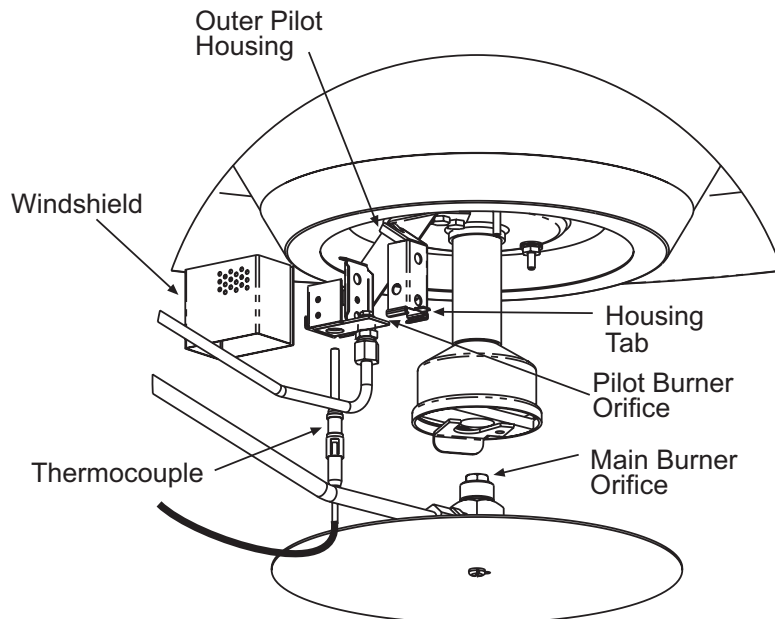

5. Clean around the burner cap ports with a bristle brush (available as an accessory, Part No. 43295010). After cleaning the burner ports, compressed air can be blown into the burner ports to blow any trash out of the burner through the burner venturi.

6. Clean both the inside and outside surfaces of the perforated emitter assembly with a large wire brush (available as an accessory, Part No. 43295020); then use compressed air to remove any burnt dust or dirt particles from the emitter.
7. Remove and clean the thermocouple when necessary.

NOTE: After reassembly of all components, check the gas connections at the burner and the gas valve for leaks. Use a heavy soapsuds solution. **DO NOT** use an open flame to check for gas leaks.

12. TROUBLESHOOTING

TROUBLE	POSSIBLE CAUSE	SOLUTIONS
<i>Pilot will not stay lit when lighting the pilot...</i>	<ul style="list-style-type: none"> ◆ There is air in the gas line. ◆ The pilot orifice is clogged. ◆ The thermocouple is defective. ◆ The pilot safety valve is defective. 	<ul style="list-style-type: none"> ◆ Bleed the air out or continue to ignite the brooder until all the air is purged. ◆ Remove and clean the orifice as necessary. ◆ Replace the thermocouple. ◆ Replace the gas valve.
<i>Brooder shuts off on pilot safety (i.e. pilot goes out)...</i>	<ul style="list-style-type: none"> ◆ The pilot orifice is clogged. ◆ The supply pressure is insufficient. ◆ The thermocouple is defective. ◆ The pilot safety valve is defective. 	<ul style="list-style-type: none"> ◆ Remove and clean the orifice as necessary. ◆ Check the manifold gas pressure and adjust as necessary. ◆ Replace the thermocouple. ◆ Replace the gas valve.
<i>Brooder is not glowing red...</i>	<ul style="list-style-type: none"> ◆ The supply gas pressure is too low. ◆ The gas piping size is incorrect. ◆ The orifice is clogged. ◆ The orifice size is incorrect. 	<ul style="list-style-type: none"> ◆ Check the manifold gas pressure and adjust as necessary. ◆ If you are not sure of the performance, use the NFPA 54 gas pipe sizing table in this manual. ◆ Remove and clean the orifice as necessary. ◆ See the instructions for correct orifice size and replace if necessary.
<i>Brooder will not attain the desired temperature...</i>	<ul style="list-style-type: none"> ◆ There is insufficient heat in the building for heat loss (i.e., not enough brooders). ◆ The thermostat sensing bulb is incorrectly placed. ◆ The thermostat is out of calibration. 	<ul style="list-style-type: none"> ◆ Conduct a heat loss and add brooders or other source of heat as necessary. ◆ Reposition the sensing bulb as necessary for proper operation. NOTE: The sensing bulb should be shielded from direct radiation to prevent short cycling of the brooder. ◆ Recalibrate (if possible) or replace.
<i>Flames flaring up, outside of emitter surface...</i>	<ul style="list-style-type: none"> ◆ The gas pressure is too high. ◆ The orifice size is incorrect. ◆ The type of gas supplied to the brooder is incorrect. ◆ There is insufficient combustion air. 	<ul style="list-style-type: none"> ◆ Check the manifold gas pressure and adjust if necessary. ◆ See instructions for correct orifice size and replace if necessary. ◆ Check the nameplate to identify the correct type of gas the brooder is equipped to operate using. ◆ Clean the inside of the burner with a wire brush and blow out with compressed air.

13. REPLACEMENT PARTS GUIDE

Item No.	Part No.	Description	HW ZONE EZ	SIT MOD EZ	SIT NON MOD EZ
1	02166070	#8-32 x 1/2" Pan Head Screw	-	2	2
1a	02167040	#8-32 Hex Locknut	2	4	4
2	02127230	#12-24 Hex Nut	1	1	1
3	02320010	#12-24 x 1/2" Hex Head Screw	1	1	1
4	02167010	1/4-20 Hex Locknut - Keps	7	7	7
5	02259010	1/4-20 x 5/8" Hex Head Screw	2	2	2
6	02309000	1/4-20 x 2" Eyebolt (includes one nut)	1	1	1
7					
8	02168050	#10-24 x 3/8" Pan Head Screw	2	2	2
9	02004010	#10-32 x 1/4" Pan Head Screw	1	1	1
10	02305010	#M8 Flat Washer	8	8	8
11	02281010	#M5 x 35mm Hex Head Screw	3	3	3
12	02282010	#M5 Hex Nut	3	7	7
13	02301010	#M5 Flat Washer	3	7	7
14	02302010	#M5 Spring Lockwasher	4	4	4
15	03577020	Cable Clamp 5/16"ID	-	2	2
16	43525150	Emitter Assembly (less burner cap)	1	1	1
17	43309000	Burner Cap	1	1	1
18	43633030	Burner Base Assembly (with swivel clamp)	1	1	1
19	43303000	Reflector Canopy - Aluminum	1	1	1
20	43303010	Reflector Canopy - Galvanized	1	1	1
21	43826010	Low Profile Hanging Bracket	1	1	1
22	43304030	Burner Pan (center mounted)	1	1	1
23	43983020	Manifold Support Assembly (radiation shield)	1	1	1
24	43982020	V-Clamp (manifold support)	1	1	1
25	03259821	Main Burner Orifice (1.8mm) - LP Gas	1	1	1
26	03259330	Main Burner Orifice (#33) - Natural Gas	1	1	1
27	03259500	Main Burner Orifice (#50) - LP/Butane Gas	1	1	1
28	43305990	Main Burner Orifice Fitting Sub-Assembly	1	1	1
29	30397000	1/2 MPT x 3/8 Tube Fitting (USA Style)	1	-	-
30	03600020	3/8" Compression Sleeve (USA Style)	1	1	1
31	03601020	3/8" Compression Nut (USA Style)	1	1	1
32	43307160	Main Burner Tubing, 3/8"	1	1	1
33	43307170	Pilot Burner Tubing, 1/4"	1	-	-
34	43307190	Pilot Burner Tubing, 1/4"	-	1	1
35	30411050	Gas Valve - Honeywell #VR8200M-2956 - Natural Gas	1	-	-
36	30411060	Gas Valve - Honeywell #VR8200M-2964 - LP Gas	1	-	-
37	30531010	Gas Valve - SIT #0630501 - Natural & LP Gas (with plug)	-	-	1
37a	3053102	Gas Valve - SIT #0630501 - LP Gas (with min. rate screw)	-	1	-
37b	3053103	Gas Valve - SIT #0630501 - Natural (with min. rate screw)	-	1	-
38	03213020	3/8 MPT x 3/8 Tube Fitting Elbow	-	1	1
39	43997050	Pilot Assembly Complete - LP Gas	1	1	1
40	43997060	Pilot Assembly Complete - Natural Gas	1	1	1
41	43997980	Pilot Housing Sub-Assembly	1	1	1
42	43996019	Pilot Housing - Outer	1	1	1
43	44002019	Pilot Windshield - Perforated	1	1	1
44	06589030	Pilot Orifice Holder - 1/8 NPT x 1/4 Tube	1	1	1
45	03260790	Pilot Orifice (#79) - LP Gas	1	1	1

STANDARD WARRANTY

THE GSI GROUP, INC. ("GSI") WARRANTS ALL PRODUCTS MANUFACTURED BY GSI TO BE FREE OF DEFECTS IN MATERIAL AND WORKMANSHIP UNDER NORMAL USAGE AND CONDITIONS FOR A PERIOD OF TWELVE MONTHS AFTER RETAIL SALE TO THE ORIGINAL END USER OF SUCH PRODUCTS. GSI'S ONLY OBLIGATION IS, AND PURCHASER'S SOLE REMEDY SHALL BE FOR GSI, TO REPAIR OR REPLACE, AT GSI'S OPTION AND EXPENSE, PRODUCTS THAT, IN GSI'S SOLE JUDGMENT, CONTAIN A MATERIAL DEFECT DUE TO MATERIALS OR WORKMANSHIP. ALL DELIVERY AND SHIPMENT CHARGES TO AND FROM GSI'S FACTORY WILL BE PURCHASER'S RESPONSIBILITY. EXPENSES INCURRED BY OR ON BEHALF OF THE PURCHASER WITHOUT PRIOR WRITTEN AUTHORIZATION FROM AN AUTHORIZED EMPLOYEE OF GSI SHALL BE THE SOLE RESPONSIBILITY OF THE PURCHASER.

EXCEPT FOR THE ABOVE STATED EXPRESS LIMITED WARRANTIES, GSI MAKES NO WARRANTY OF ANY KIND, EXPRESSED OR IMPLIED, INCLUDING, WITHOUT LIMITATION, WARRANTIES OF MERCHANTABILITY OR FITNESS FOR A PARTICULAR PURPOSE OR USE IN CONNECTION WITH (i) PRODUCT MANUFACTURED OR SOLD BY GSI OR (ii) ANY ADVICE, INSTRUCTION, RECOMMENDATION OR SUGGESTION PROVIDED BY AN AGENT, REPRESENTATIVE OR EMPLOYEE OF GSI REGARDING OR RELATED TO THE CONFIGURATION, INSTALLATION, LAYOUT, SUITABILITY FOR A PARTICULAR PURPOSE, OR DESIGN OF SUCH PRODUCT OR PRODUCTS.

IN NO EVENT SHALL GSI BE LIABLE FOR ANY DIRECT, INDIRECT, INCIDENTAL OR CONSEQUENTIAL DAMAGES, INCLUDING, WITHOUT LIMITATION, LOSS OF ANTICIPATED PROFITS OR BENEFITS. PURCHASER'S SOLE AND EXCLUSIVE REMEDY SHALL BE LIMITED TO THAT STATED ABOVE, WHICH SHALL NOT EXCEED THE AMOUNT PAID FOR THE PRODUCT PURCHASED. THIS WARRANTY IS NOT TRANSFERABLE AND APPLIES ONLY TO THE ORIGINAL PURCHASER. GSI SHALL HAVE NO OBLIGATION OR RESPONSIBILITY FOR ANY REPRESENTATIVE OR WARRANTIES MADE BY OR ON BEHALF OF ANY DEALER, AGENT OR DISTRIBUTOR OF GSI.

GSI ASSUMES NO RESPONSIBILITY FOR FIELD MODIFICATIONS OR ERECTION DEFECTS WHICH CREATE STRUCTURAL OR STORAGE QUALITY PROBLEMS. MODIFICATIONS TO THE PRODUCT NOT SPECIFICALLY COVERED BY THE CONTENTS OF THIS MANUAL WILL NULLIFY ANY PRODUCT WARRANTY THAT MIGHT HAVE BEEN OTHERWISE AVAILABLE.

THE FOREGOING WARRANTY SHALL NOT COVER PRODUCTS OR PARTS WHICH HAVE BEEN DAMAGED BY NEGLIGENT USE, MISUSE, ALTERATION OR ACCIDENT. THIS WARRANTY COVERS ONLY PRODUCTS MANUFACTURED BY GSI. THIS WARRANTY IS EXCLUSIVE AND IN LIEU OF ALL OTHER WARRANTIES EXPRESS OR IMPLIED. GSI RESERVES THE RIGHT TO MAKE DESIGN OR SPECIFICATION CHANGES AT ANY TIME.

PRIOR TO INSTALLATION, PURCHASER HAS THE RESPONSIBILITY TO RESEARCH AND COMPLY WITH ALL FEDERAL, STATE AND LOCAL CODES WHICH MAY APPLY TO THE LOCATION AND INSTALLATION.

07/21/98

For replacement parts, please contact your local distributor or:
CUMBERLAND
1004 E. Illinois Street · Assumption, IL 62510(217) 226-4401