

Owner's Manual



SUPER-SAVER XL™ HEATER

HIRED-HAND®

Agricultural Building Heater

Model SS-225-XL

65.9 kW

225,000 BTUH



- ◆ **Hot Surface Ignition**
- ◆ **Wash Down Design**



FOR YOUR SAFETY

If You Smell Gas:

1. Open windows
2. Do not touch electrical switches
3. Extinguish any open flames
4. Immediately call your gas supplier

FOR YOUR SAFETY

Do not store or use gasoline or any flammable vapors and liquids in the vicinity of this or any other appliance

CONSIGNES DE SECURITE

Si vous sentez une odeur de gaz:

1. Ouvrez les fenetres
2. Ne touchez pas aux interrupteurs electriques
3. Etegnex toute flamme hue
4. Contactez immediatement votre compangie de gaz

CONSIGNES DE SECURITE

Il es interdit d'utiliser des liquides inflammables ou degageant des vapeurs inflammables, a proximite de tout appareil fonctionnant au gaz

Retain Instructions For Future Reference

GENERAL HAZARD WARNING

Failure to comply with precautions and instructions provided with this heater can result in death, serious bodily injury and property loss or damage from hazards of fire, explosion, burn, asphyxiation, carbon monoxide poisoning, and/or electrical shock. If you need assistance or heater information such as an instruction manual, labels, etc. contact the manufacturer.

WARNING

Keep solid combustibles, such as building materials, paper or cardboard, feathers, and dust a safe distance away from the heater as recommended by the instructions. Never use the heater in spaces which contain or may contain volatile airborne combustibles, or products such as gasoline, solvents, paint thinner, dust particles, or unknown chemicals. Failure to follow these instructions may result in a fire or explosion, property damage, personal injury or loss of life.

WARNING

Not for home or recreational vehicle use. Installation of this heater in a home or recreational vehicle may result in a fire or explosion, property damage, personal injury or loss of life.

WARNING

Before installation, check that the local distribution conditions, nature of gas and pressure, and the current state of adjustment of the appliances are compatible.

CAUTION

A qualified installer is required to install, commission, adjust, and where applicable, convert the appliance for use with other gases.

Table Of Contents

1.	Specifications And Requirements.....	3
2.	Warnings And Cautions.....	4
3.	Maintenance And Warranty.....	5
4.	Installation.....	7
5.	User Instructions.....	9
6.	Gas/Air Requirements.....	11
7.	Conversion To Other Gases.....	11
8.	Component And Wiring Diagram.....	14
9.	Ladder Type Schematic Diagram.....	15
10.	Servicing Instructions.....	16
11.	Pipe Sizing For Sufficient Gas Service.....	21
12.	Parts & Assemblies.....	23

MINIMUM CLEARANCES

Measured From	Inches	mm
Ceiling	12	305
Wall	12	305
Floor	20	500
Livestock must not be allowed to contact heater or come within 3 meters (10 feet) of hot air discharge		

1. Specifications And Requirements

BE SURE TO CHECK DELIVERY!

Locate packing slip and make sure all of the listed parts are enclosed. If not, call your Hired-Hand Distributor immediately.

HEATER DIMENSIONS

WEIGHT	60 kG (130 lb.)
HEIGHT	76.2 cm (30 in.)
WIDTH	62.2 cm (24½ in.)
DEPTH	48.9 cm (19¼ in.)



Adjustable Wrench
Pipe Glue
Gas Leak Testing
¼ in. (7 mm.) Nut Driver
Install screw hooks with hammer or drill.

Model No.	Maximum Input	Ventilation
SS-225-XL	65.9 kW (225,000 BTUH)	1700 m ³ /h (1000 CFM)
Butane & Propane Gas:	Maximum 57.5 mbar (22.7 in. w.c.) and minimum 25 mbar (9.9 in. w.c.) inlet gas supply pressure acceptable at heater input. Burner manifold pressure 25 mbar (10 in. w.c.) at maximum input. Gas pressure should be checked by certified gas technician while heater is in operation. All sealing devices must be restored after the gas conversion. Refer to Section 7. Gas/Air requirements.	
Natural Gas:	Maximum 25 mbar (9.9 in. w.c.) and minimum 17 mbar (6.7 in. w.c.) inlet gas pressure acceptable at heater input. Burner manifold pressure 9.45 mbar (3.8 in. w.c.) at maximum input. Gas pressure should be checked by a certified gas technician while heater is in operation. All sealing devices must be restored after the gas conversion. Refer to Section 7. Gas/Air requirements.	
LHV Natural Gas	Maximum 30 mbar (11.9 in. w.c.) and minimum 20 mbar (7.9 in. w.c.) inlet gas supply pressure acceptable at heater input. Burner manifold pressure 14.1 mbar (5.6 in. w.c.) at maximum input. Gas pressure should be checked by a certified gas technician while heater is in operation. All sealing devices must be restored after the gas conversion. Refer to Section 7. Gas/Air requirements.	
Refer to heater ratings plate for unit voltage, amperage, and frequency ratings.		
<i>READ ALL INSTRUCTIONS BEFORE YOU START ASSEMBLING</i>		

2. Warnings And Cautions

WARNING

If Connected To A Remote Thermostat
Heater May Start At Any Time!

CAUTION!

1. Before installation, check that the local distribution conditions, nature of gas and pressure, and the current state of adjustment of the appliance are compatible.
2. Follow safety, maintenance, and test firing instructions packaged with Heater.
3. Refer to model specifications label for gas type.
4. Check all connections for gas leaks.
5. Gas supply and regulator must be installed outside building.
6. The hose assembly should be protected from traffic, building materials, and any contact with hot surfaces both during and while in storage.
7. Do not open doors, or move or handle heater while hot, burning, or connected to power supply.
8. Turn power off before servicing. (Heater may start at any time if power is connected).
9. Heater is not recommended for heating human living quarters.
10. Not to be used for heating where flammable liquids and vapors are stored or used.
11. Inadequate gas volume and (or) pressure will directly influence the combustion efficiency of the heater. Adequate gas volume and (or) pressure is the responsibility of the installer.
12. Adequate ventilation must be provided.
13. Combustion and ventilation air must not be obstructed.
14. Not for use with duct work other than types provided by manufacturer.
15. Position heater properly before use. Heater must be level and in accordance with minimum clearances.
16. For safety, this heater is equipped with air flow proving switch and manual-reset high limit switch.
17. Keep temperature of fuel containers below 37.8°C (100°F). Containers must be installed outside building.
18. Heater must not be operated for one hour following wash-down.

3. Maintenance and Warranty

MAINTENANCE	
1.	This appliance is in compliance with EN 12669 and must be commissioned after servicing. A qualified installer is required to install, commission, and adjust appliance.
2.	The appliance area should be kept clear & free from combustible materials, gasoline and other flammable vapors, and liquids.
3.	The flow of combustion and ventilation air must not be obstructed.
4.	Your Super Saver XL Heater should be inspected before each use, and at least annually by a qualified service person.
5.	The hose should be visually inspected prior to each use of the heater. If it is evident there is excessive abrasion or wear or the hose is cut, it must be replaced prior to the heater being put into operation. The replacement hose assembly shall be that specified by the manufacturer. (See parts list).
6.	Inspect heater and gas connections periodically for gas leaks with an approved gas leak testing solution (soap and water work well).
7.	Keep heater clean at all times.
A.	Open doors and blow out dust with high pressure air hose. Be sure interior of burner and flared end are kept clean.
B.	Burner orifice and hot surface ignition assembly must be kept clean and free of carbon build-up.
C.	Check blower wheel regularly for dust accumulation and clean periodically for maximum airflow.
D.	Thermostat coils must be kept clean to assure proper temperature control.
E.	Igniter must be cool before wash down. Do not operate heater for one hour following wash-down.



Limited Warranty

4. Warranty

The GSI Group, LLC. (“GSI”) warrants products which it manufactures to be free of defects in materials and workmanship under normal usage and conditions for a period of 12 months after sale to the original end-user or if a foreign sale, 14 months from arrival at port of discharge, whichever is earlier. The end-user’s sole remedy (and GSI’s only obligation) is to repair or replace, at GSI’s option and expense, products that in GSI’s judgment, contain a material defect in materials or workmanship. Expenses incurred by or on behalf of the end-user without prior written authorization from the GSI Warranty Group shall be the sole responsibility of the end-user.

Warranty Extensions: The Limited Warranty period is extended for the following products:

	Product	Warranty Period
AP Fans and Flooring	Performer Series Direct Drive Fan Motor	3 Years
	All Fiberglass Housings	Lifetime
	All Fiberglass Propellers	Lifetime
Cumberland Feeding/Watering Systems	Feeder System Pan Assemblies	5 Years **
	Feed Tubes (1.75" & 2.00")	10 Years *
	Centerless Augers	10 Years *
	Watering Nipples	10 Years *
Grain Systems	Grain Bin Structural Design	5 Years
Grain Systems Farm Fans Zimmerman	Portable & Tower Dryers	2 Years
	Portable & Tower Dryer Frames and Internal Infrastructure †	5 Years

* Warranty prorated from list price:
 0 to 3 years – no cost to end-user
 3 to 5 years – end-user pays 25%
 5 to 7 years – end-user pays 50%
 7 to 10 years – end user pays 75%

** Warranty prorated from list price:
 0 to 3 years – no cost to end-user
 3 to 5 years – end-user pays 50%

† Motors, burner components and moving parts not included. Portable Dryer screens included. Tower Dryer screens not included.

GSI further warrants that the frame, basket and excluding all auger and auger drive components of the portable and tower drier shall be free from defects in materials for a period of time beginning on the twelfth (12th) month from the date of purchase and continuing until the sixtieth (60th) month from the date of purchase (extended warranty period). During the extended warranty period, GSI will replace the frame or basket components that prove to be defective under normal conditions of use without charge, excluding the labor, transportation, and/or shipping costs incurred in the performance of this extended warranty.

Conditions and Limitations:

THERE ARE NO WARRANTIES THAT EXTEND BEYOND THE LIMITED WARRANTY DESCRIPTION SET FORTH ABOVE. SPECIFICALLY, GSI MAKES NO FURTHER WARRANTY OF ANY KIND, EXPRESS OR IMPLIED, INCLUDING, WITHOUT LIMITATION, WARRANTIES OF MERCHANTABILITY OR FITNESS FOR A PARTICULAR PURPOSE OR USE IN CONNECTION WITH: (i) PRODUCT MANUFACTURED OR SOLD BY GSI OR (ii) ANY ADVICE, INSTRUCTION, RECOMMENDATION OR SUGGESTION PROVIDED BY AN AGENT, REPRESENTATIVE OR EMPLOYEE OF GSI REGARDING OR RELATED TO THE CONFIGURATION, INSTALLATION, LAYOUT, SUITABILITY FOR A PARTICULAR PURPOSE, OR DESIGN OF SUCH PRODUCTS.

GSI shall not be liable for any direct, indirect, incidental or consequential damages, including, without limitation, loss of anticipated profits or benefits. The sole and exclusive remedy is set forth in the Limited Warranty, which shall not exceed the amount paid for the product purchased. This warranty is not transferable and applies only to the original end-user. GSI shall have no obligation or responsibility for any representations or warranties made by or on behalf of any dealer, agent or distributor.

GSI assumes no responsibility for claims resulting from construction defects or unauthorized modifications to products which it manufactured. Modifications to products not specifically delineated in the manual accompanying the equipment at initial sale will void the Limited Warranty.

This Limited Warranty shall not extend to products or parts which have been damaged by negligent use, misuse, alteration, accident or which have been improperly/inadequately maintained. This Limited Warranty extends solely to products manufactured by GSI.

Prior to installation, the end-user has the responsibility to comply with federal, state and local codes which apply to the location and installation of products manufactured or sold by GSI.

5. Installation

4.1 Hanging The Heater

Chain Suspension	Cable Suspension
<p>Mount heater with screw hooks and chains so that back of heater is at least 305 mm (12 inches) from ceiling and wall. Heater must be a minimum of 500 mm (20 inches) from floor, and located so livestock and combustible materials are unable to come in contact with heater or within 3 meters (10 feet) of hot air discharge (Fig. 1)</p>	<p>If frequent height adjustment is required, use cables and pulleys as shown in Fig. 2. Main line cable would be connected to a winch (not shown).</p>

5.2 Directions For Leveling

Adjust cables or chains as required to level the heater. Use a carpenter's level to check that the heater is level.

5.3 Installing Dual-Flare Duct

Install Dual-Flare duct (Fig. 3) as shown with sheet metal screws provided. This provides a multi-directional heat flow that may be set by bending flaps.

5.4 Connecting The Gas Supply

For gas connection (Fig. 4) attach regulator to the Hi-Pressure Line (A) at outside of building. Connect flexible hose (B) to low pressure end of regulator with special brass coupling. See page 1 for LP, natural gas, and LHV natural gas requirements.

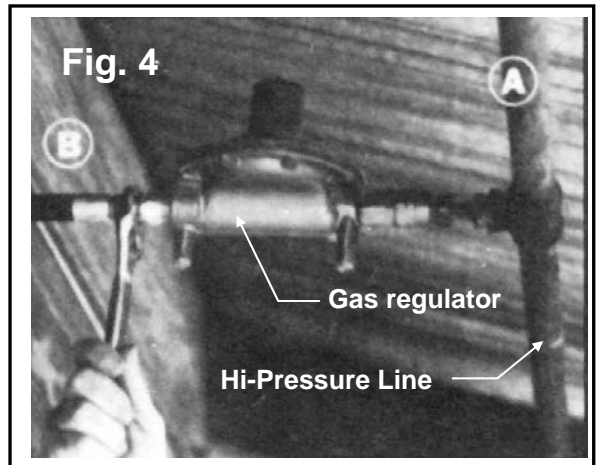
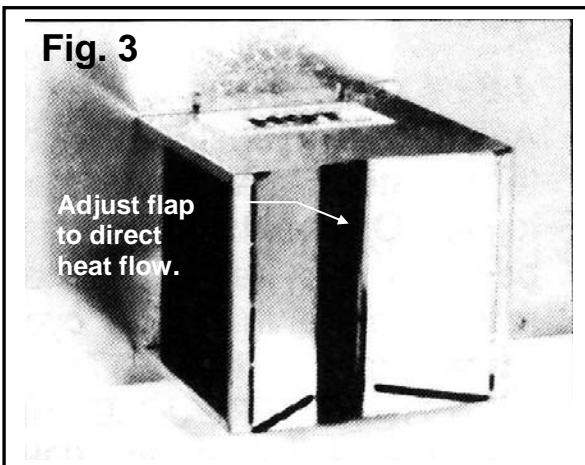
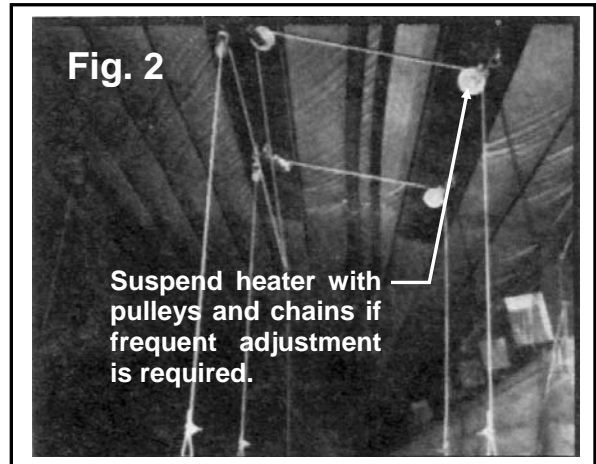
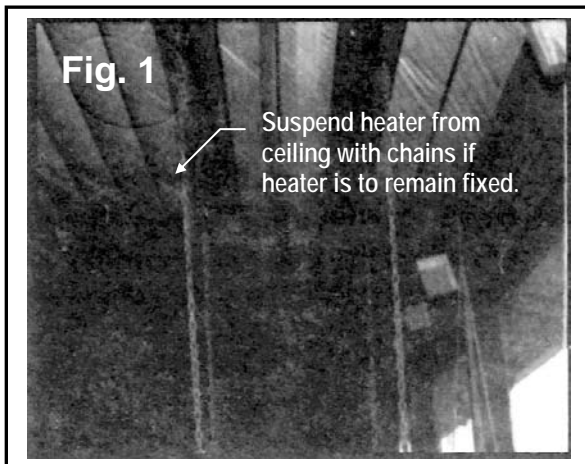

5.5 Outside Mount (Optional)

Hired-Hand heaters are available in Outside Mount (OSM) models. These heaters are designed to be mounted to the outside wall of a building. This saves valuable space inside the building and ensures fresh air intake for the heater. If you have purchased one of our OSM heaters, please read the following before installing your new heater.

1. Before disposing of the box, cut the installation template from the side.
2. Position template on outside of building where heater is to be mounted. Be sure the template is level.
3. Drill 6.3 mm (1/4") holes through all 8 X's shown on template. NOTE: Opening for duct measures 254 mm (10") width (W) x 254mm (10") height (H). See Detail A.
4. Locate 4 X's for thru-wall extension duct and cut from one hole to the next until opening is removed. See Detail A.
5. If additional support is needed, add support by fastening two '2 x 4' boards on outside of wall where heater support brackets are to be positioned. The two '2 x 4' boards are to be fastened to studs inside the wall. See Detail B.
6. Assemble heater support bracket as shown in Detail C.
7. Attach Insert thru-wall extension duct assembly through opening in wall. The 'varmint' flap, located inside the thru-wall extension duct, should be positioned as shown in Detail D.
8. Bend extension duct mounting flange into a rectangle and fasten around exhaust outlet on front of heater with sheet metal screws provided.
9. Place heater on support bracket. Support bracket must be level before heater is set in place.
10. Slide thru-wall extension duct assembly into flange, and secure with sheet metal screws.
11. Place outer flashing seal around thru-wall extension duct and secure with sheet metal screws to inside of wall.
12. Fasten directional duct to extension duct mounting flange, then bend deflectors until they force heated air in the desired direction.
13. To continue with installation of your heater, see 'User Instructions' section on the next page.

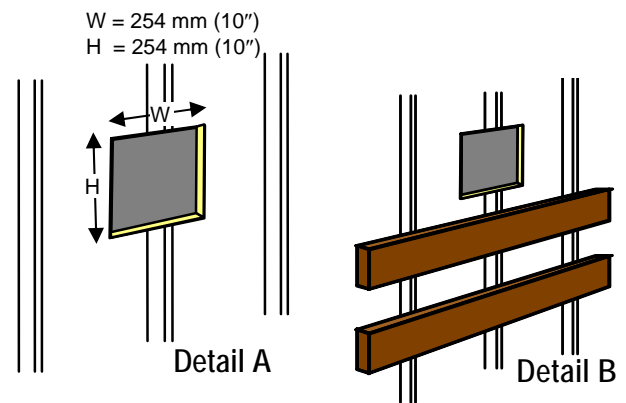

CAUTION!

The minimum side clearance to combustible walls must be 305 mm (12 inches).

The minimum clearance between the appliance and rear wall must be 305 mm (12 inches).

Weeds, snow, or other materials must not be allowed to accumulate on heater or adjacent to heater. Heater and thru-wall extension duct must be a minimum of 500 mm (20 inches) above ground and out of reach of livestock.

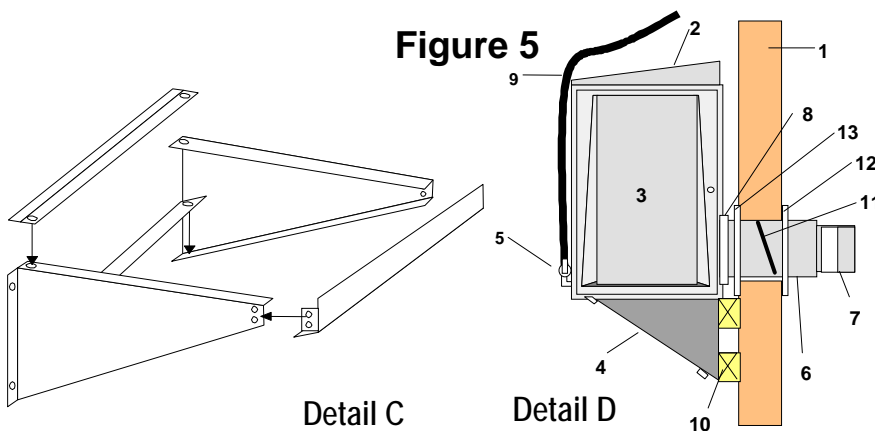

Legend

1. Wall (By others)
2. Rain shield, included with OSM heater.
3. Door, included with OSM heater.
4. Mounting brace, included with OSM kit.
5. Gas shutoff valve, included with heater.
6. Thru-wall extension duct, included with OSM kit.
7. Dual flare duct. Use T-duct included with heater or use optional OSM Y-duct ordered separately.
8. Extension flange, included with OSM kit.
9. Gas hose, optional ordered separately.
10. 2 x 4 Framing for Brace, not included
11. 'Varmint' flap, included with OSM kit.
12. Inner flashing seal, included with OSM kit.
13. Outer flashing, included with OSM kit.

6. User Instructions

Before turning on gas, check main supply valve to be sure it is open (Figure 8). Be sure to check all connections for leaks with a Gas Leak Testing solution, (soap and water work well). Check to see if gas valve knob is in the ON position. If not, turn counter-clockwise until knob “clicks” into the ON position. (This may not apply to all units). Turn on gas by turning ball valve handle into vertical position.

6.1 Connecting Electrical Power

Make sure a circuit breaker or similar cutoff device is provided to permit disconnection of electrical power to heater for service and cleaning. All wiring must meet local electrical codes. This heater is designed to be wired directly, with no plugs and outlets necessary. All electrical work should be performed by a certified electrician. The wiring diagrams in Sections 8 and 9 shows how to wire a 230V, 50 Hz power supply directly to the heater’s terminal block. If no adjustments are made, the heater will operate every time power is supplied and the on/off switch is activated. If an external thermostat is to be used (See Component & Wiring Diagram), the heater will operate only when power is supplied, the on/off switch is activated, and the thermostat indicates a call for heat.

1. Route the power cable (customer supplied) through the metal cabinet grommet. Refer to Figure 6.
2. Assemble the black cable fitting and supplied fitting nut to the control box and tighten securely.
3. Install a heat-protective sleeve (customer provided) around the power cable from the metal grommet to the black cable fitting. Route the power cable through the black cable fitting and into the control box. Refer to Figure 7.
4. Make the necessary electrical connections as shown in Sections 8 & 9 Wiring Diagrams.
5. Tighten the black cable fitting dome-shaped nut securely around the power cable.
6. Secure the power cable to the existing wire harness with cable ties. DO NOT allow the power cable near or touching metal surfaces. **WARNING:** Metal surfaces are HOT during operation.
7. Tighten the two metal grommet screws securely by hand.

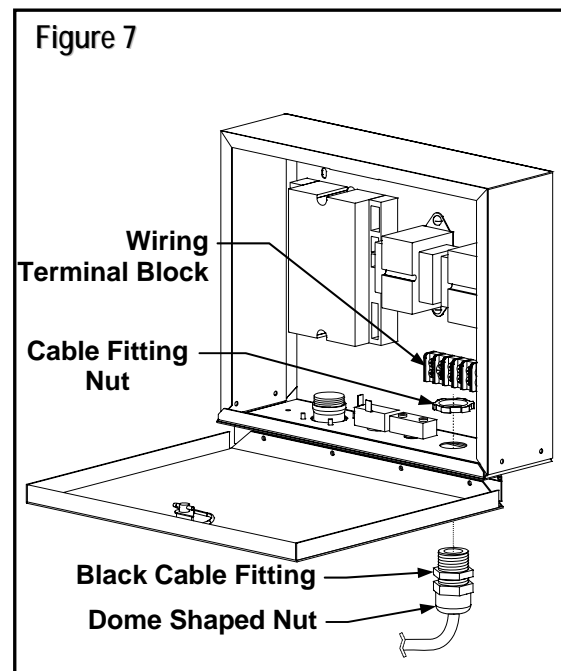
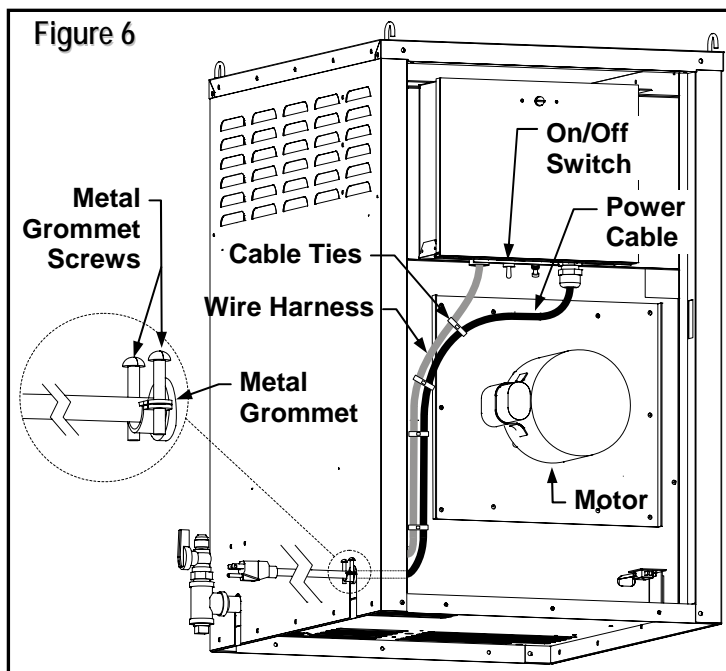

6.2 Starting Up

Adjust thermostat higher than house temperature. Allow 20 seconds for heater to ignite. On initial start up or when heater has not been in service for some time, heater may require more than one attempt to purge air and ignite heater. (IF HEATER FAILS TO IGNITE, REFER TO TROUBLE SHOOTING GUIDE). Adjust thermostat to desired house temperature.

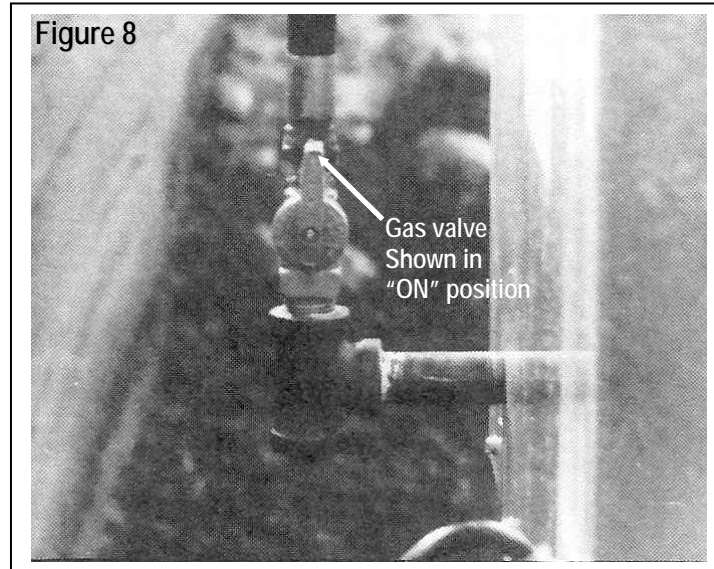

6.3 Shutting OFF Heater

Shut off main gas supply valve, close ball valve, and disconnect electrical power.

CAUTION!

LIMITING EXCESS CARBON DIOXIDE (CO₂)

In order to prevent hazardous accumulation of CO₂ gases, the heater must operate ONLY in a properly ventilated room.

The Gas/Air Requirement table (**Section 6**) lists the minimum amount of fresh air required for heater to limit CO₂ to safe levels.

Both installer and operator must ensure that the building's ventilation rate never drops below the noted limits.

7. Gas/Air Requirements

Table 1: Gas/Air Requirements

Appliance Category	Gas Number	Common Name	Inlet Pressure (mbar)	Operating Pressure (mbar)	Orifice Dia. (mm) Below 610m	Conversion Kit TO the stated Category
2H, 2E	G20	Natural Gas	20	9.45	9.15	6450-9085
2L	G25	Low Heat Value Nat. Gas	25	14.10	9.15	6450-9085
3B/P	G30/G31	Butane/Propane	30/50	25.00	4.57	6450-9087
3P	G31	Propane	37	25.00	4.69	6450-9086

Appliance Category	Gas Number	Flow Rate	Combustion Air Required (m ³ /hr)	Ventilation Provided (m ³ /h)	CO ₂ Limit Air Required (m ³ /hr)	Cal. Value* (MJ/m ³)
2H,2E	G20	6.28 m ³ /hr	60	1700	238	37.78
2L	G25	7.31 m ³ /hr	60	1700	266	32.49
3B/P	G30/G31	4.8 kg/hr	58	1700	160	125.81
3P	G31	4.71 kg/hr	59	1700	115	95.65

Source: Adopted European Standard EN 437:1993

*Gross Cal. Values, 15°C (59°F), 1013.25 mbar (406.78 in. w.c.)

8. Conversion To Other Gases

8.1 Tools Required

Adjustable Wrench Pipe Wrench Pipe Sealant Gas Leak Testing Solution

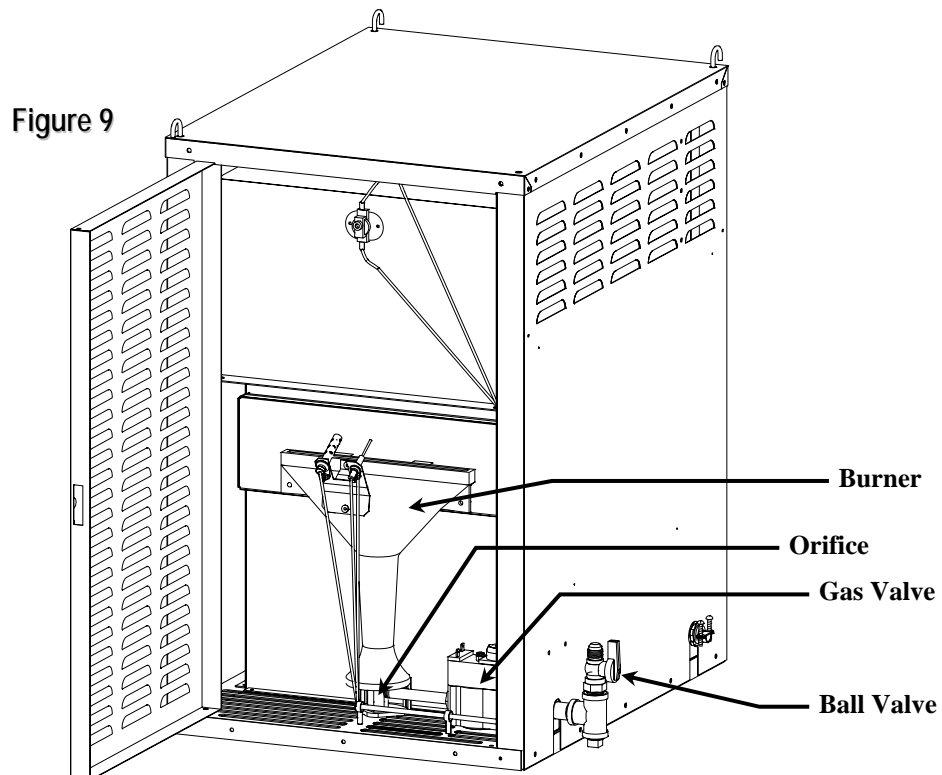

8.2 Orifice Replacement

⚠ WARNING

FIRE OR EXPLOSION HAZARD - - CAN CAUSE PROPERTY DAMAGE, SEVERE INJURY, OR DEATH.

- Disconnect power supply before wiring to prevent electrical shock or equipment damage.
- To avoid dangerous accumulation of fuel gas, turn off gas supply at service valve before starting installation and perform gas leak test after completion of installation.
- Use hand operation only to turn gas control knob. If gas control knob will not operate by hand, have a qualified technician replace the gas control. Forcing the knob with any tools may result in fire or explosion.

Read all instructions carefully. Failure to follow instructions can cause severe personal injury or property damage. The installer of this product should be a trained experienced service technician.

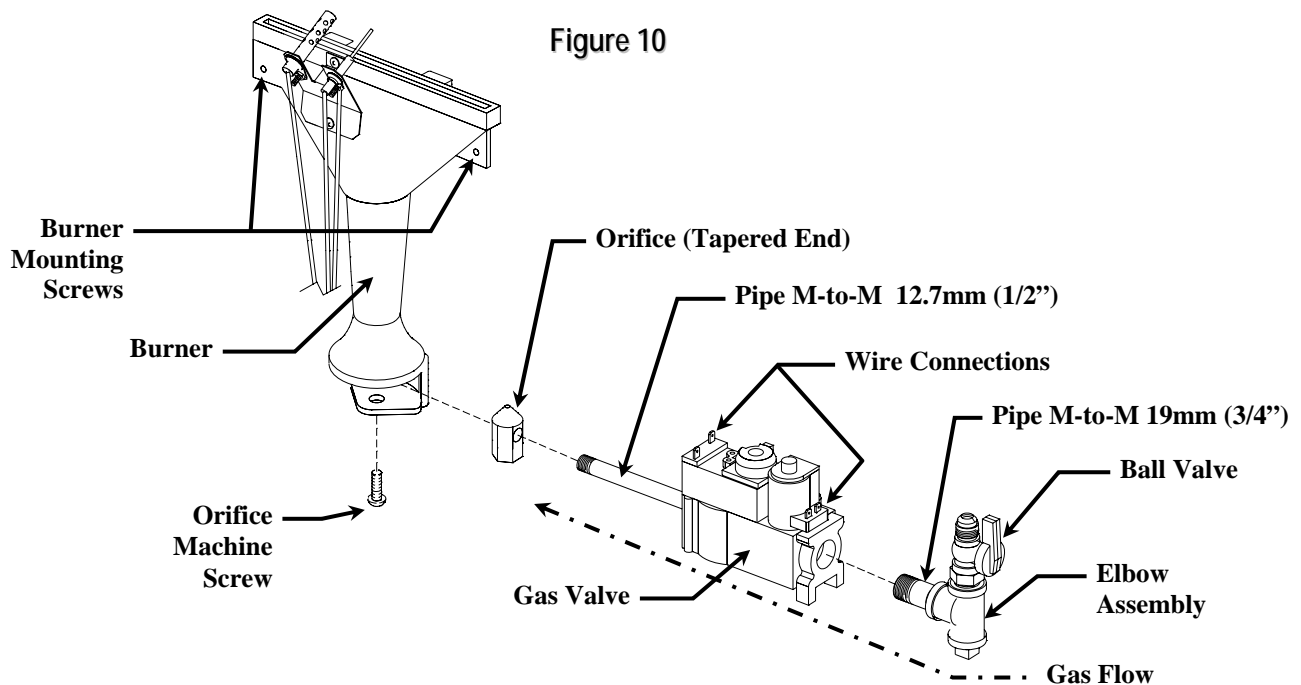

Qualified Gas Technician Use Only

1. Turn the On/Off switch (Refer to Figure 6), located on the heater control panel to the OFF position.
 2. Disconnect heater from the power source.
 3. Turn the Ball Valve to the CLOSED position.
 4. Turn OFF gas supply at source and disconnect the gas supply line/hose from the Ball Valve.
 5. Unplug the wires connected to the Gas Valve assembly and ensure notes are taken to represent the proper wire locations for reconnection.
 6. Remove the Ball Valve, Elbow assembly, and 19mm (3/4'') M-to-M Pipe from the Gas Valve (counter-clockwise).
- NOTE:** If the 19mm (3/4'') M-to-M Pipe does not turn loose from the Gas Valve, the Burner Mounting Screws may be loosened to allow Gas Valve assembly removal.
7. Remove the machine screw beneath the Orifice.
 8. Twist the Gas Valve / Orifice assembly to free it from the Burner.

9. Loosen and remove the Orifice from the 12.7mm (1/2") pipe.
10. Apply pipe sealant to threads and reinstall the new Orifice to the 12.7mm (1/2") pipe. Replace with the appropriate orifice for the new gas type (**Refer to Table 1**).

NOTE: Ensure the tapered portion of the Orifice points straight upward when installed to the Gas Valve Assembly.

NOTE: Extra care should be taken to avoid turning the pipe too far into the orifice. The pipe should not restrict gas flow through the orifice. A drill bit may be used as a stop-guide if placed down through the Orifice opening while threading the Orifice onto the pipe. When the Orifice is properly threaded onto the pipe, remove the drill bit from the Orifice opening and ensure the drill bit is removed before continuing assembly.

11. Place the Gas Valve assembly with the Orifice inside the Burner and allow the Gas Valve to rest in the support bracket.
12. Install the machine screw thru the cabinet bottom and into the bottom of the Orifice. Tighten securely.
13. Apply pipe sealant to the threads and snugly reinstall the ball valve, elbow, and 19mm (3/4") M-to-M Pipe to the Gas Valve.
14. Reconnect the wires to the Gas Valve assembly and ensure the wires are connected to the proper terminals.
15. Apply pipe sealant to the threads of the Ball Valve and connect the gas supply hose.
16. Turn the main gas supply ON.
17. Turn the Ball Valve to the ON position.
18. Check for gas leaks. (A soap and water mixture works well.) Allow all areas to completely dry.
19. Connect the heater to the power source.
20. Turn the toggle switch, located on the control panel, to the ON position.

8.3 Adjust the Manifold Pressure

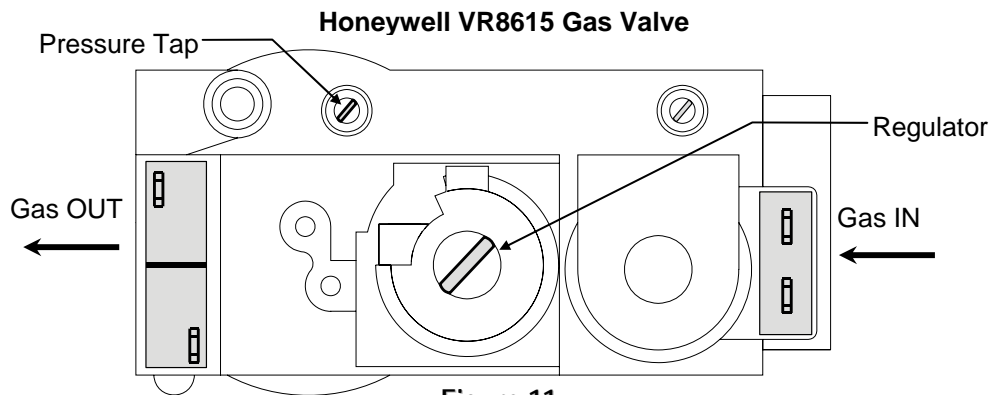

Figure 11

Qualified Gas Technician Use Only!

1. Turn the toggle switch, located on the control panel, to the OFF position.
 2. Disconnect heater from the power source.
 3. Turn the Ball Valve to the CLOSED position.
 4. Turn OFF gas supply at source.
 5. Completely loosen pressure tap and remove regulator screw metal cap on gas valve.
- NOTE:** Do not remove the plastic regulator adjustment screw beneath the metal cap.
6. Fit a gas pressure gauge on the pressure tap of the gas valve. **NOTE:** A standard barbed fitting may be required for this connection.
 7. Reconnect gas, power supply, and turn the Ball Valve ON.
 8. Start heater and monitor the supply and operating pressures.
 9. Check supply pressure to ensure supply pressure is within the heater's operating limits (**See Table 1, Gas/Air Requirements**).
 10. Adjust the gas valve regulator to set the operating pressure as specified in **Table 1, Gas/Air Requirements**. The plastic regulator adjustment screw is already sealed after adjustment.
 11. Replace the regulator screw metal cap.
 12. Turn OFF heater.
 13. Remove gas pressure gauge and tighten the pressure tap securely.
 14. Verify proper heater operation and perform gas leak test at the Pressure Tap.

9. Component And Wiring Diagram

COMPONENT AND WIRING DIAGRAM

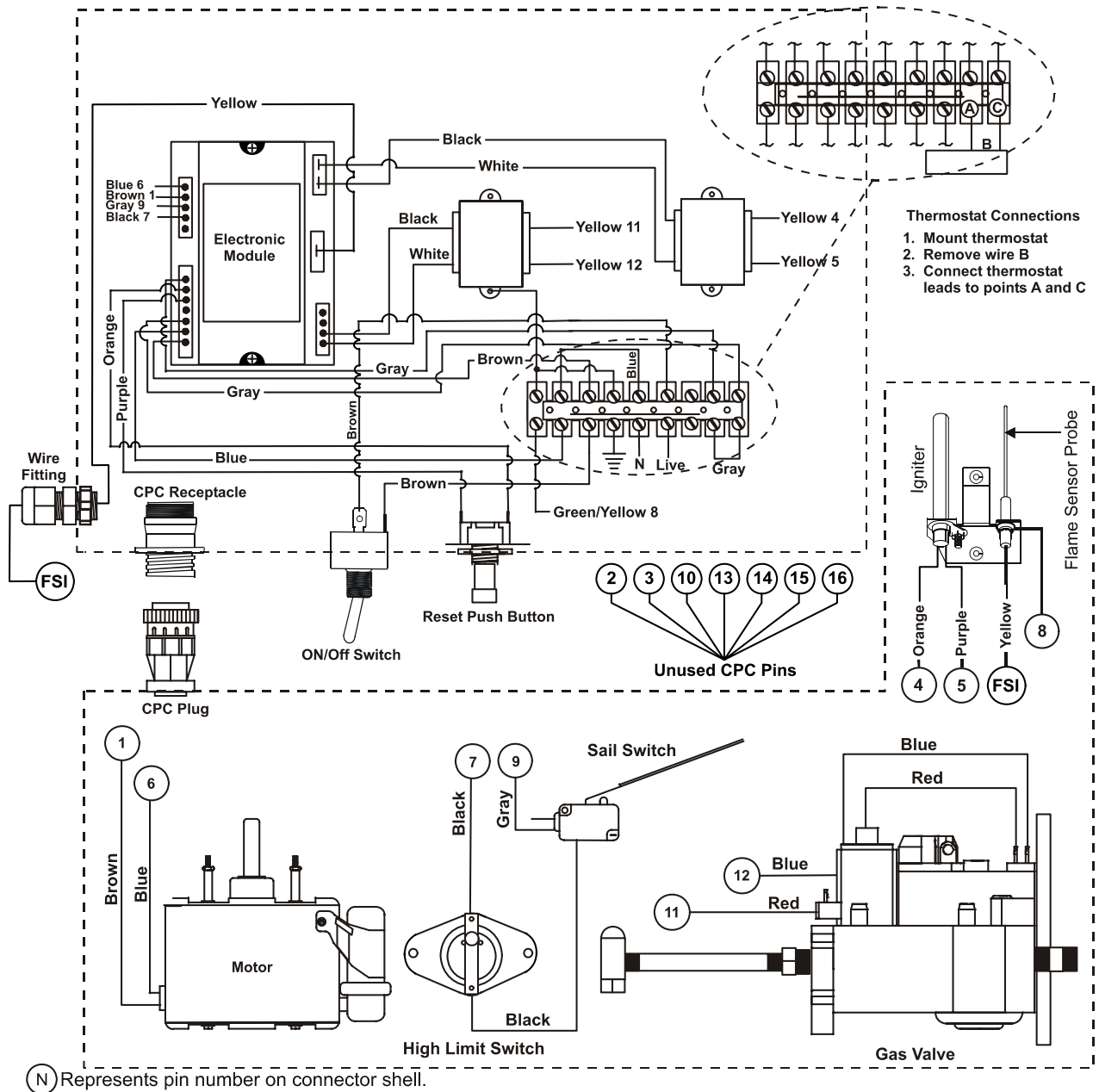

230 Volts A. C. 50 Hz Single Phase

11. Servicing Instructions

IMPORTANT!

Inspect and check operation of this appliance monthly. Follow the instructions below. If a problem is detected, contact a qualified technician to make any necessary repairs.

In an effort to minimize the time required to trouble shoot this system:

1. Turn off the gas supply at the main gas valve.
2. Disconnect electric power to system at main fuse of circuit breaker, if connected.
3. Visually inspect equipment for apparent damage. Check wiring for loose connections.
5. Inspect igniter for visible cracking or scale deposits. Inspect flame sensor for position or deposits shorting sensor to burner.
5. After performing the above inspections, restore gas supply, and electric power to the equipment. Close thermostat contacts to cycle the system. If a “no heat” condition persists, the three visual indicators listed below will help determine if system is operating properly.

- 1** The igniter will warm up and glow bright red.
- 2** The main burner flame will ignite.
- 3** The main burner flame will continue to burn after the igniter is turned off.

Trouble shooting the system consists of checking for these three visual indications. The Visual Check Charts define the proper action if any of these indications do not occur.

- Visual checks are an important and easy method to ensure that your Hired-Hand heater continues to operate properly. These checks should be performed regularly.
- If a problem is detected, it is recommended to contact a qualified technician to make the necessary repairs. **The appliance must be recommissioned by a qualified technician after servicing is completed.**
- Detailed drawings and a replacement parts list are located at the end of this manual.
- Consult Hired-Hand before replacing any heater component with a non-standard part.
- This heater is designed to require a minimum of servicing, but in the case it does become necessary, the design provides easy access to each component.

11.1 *Checking Manifold Pressure*

To be performed by a certified gas technician only!

1. Unplug heater from power source and turn ball valve to OFF position.
2. Remove outlet pressure tap plug from gas control valve and connect pressure gauge.
3. Return electrical power to heater and plug to power source and turn ball valve to ON position.
4. To obtain an accurate manifold pressure reading, heater must be cycled on and off several times to stabilize the pressure regulator diaphragm.
5. Return the heater to operation and read pressure gauge.
6. If necessary, adjust pressure regulator on gas control valve to the acceptable manifold pressure found on rating plate and page 1 of owner's manual.
7. Remove pressure regulator adjustment screw.
8. Using a screwdriver, turn inner adjustment screw clockwise to increase or counter clockwise to decrease manifold pressure to burner.
9. Always replace cap screw and tighten firmly to prevent gas leakage.
10. Unplug heater from power source and turn ball valve to OFF position.
11. Remove pressure gauge and replace outlet pressure tap plug.
12. Return heater to operation and observe through at least one complete cycle to ensure all controls are operating properly.
13. Perform gas leak test at outlet pressure tap plug. (Soap and water work well).

11.2 Chart 1 First Visual Check

**Chart 1
First Visual Check**

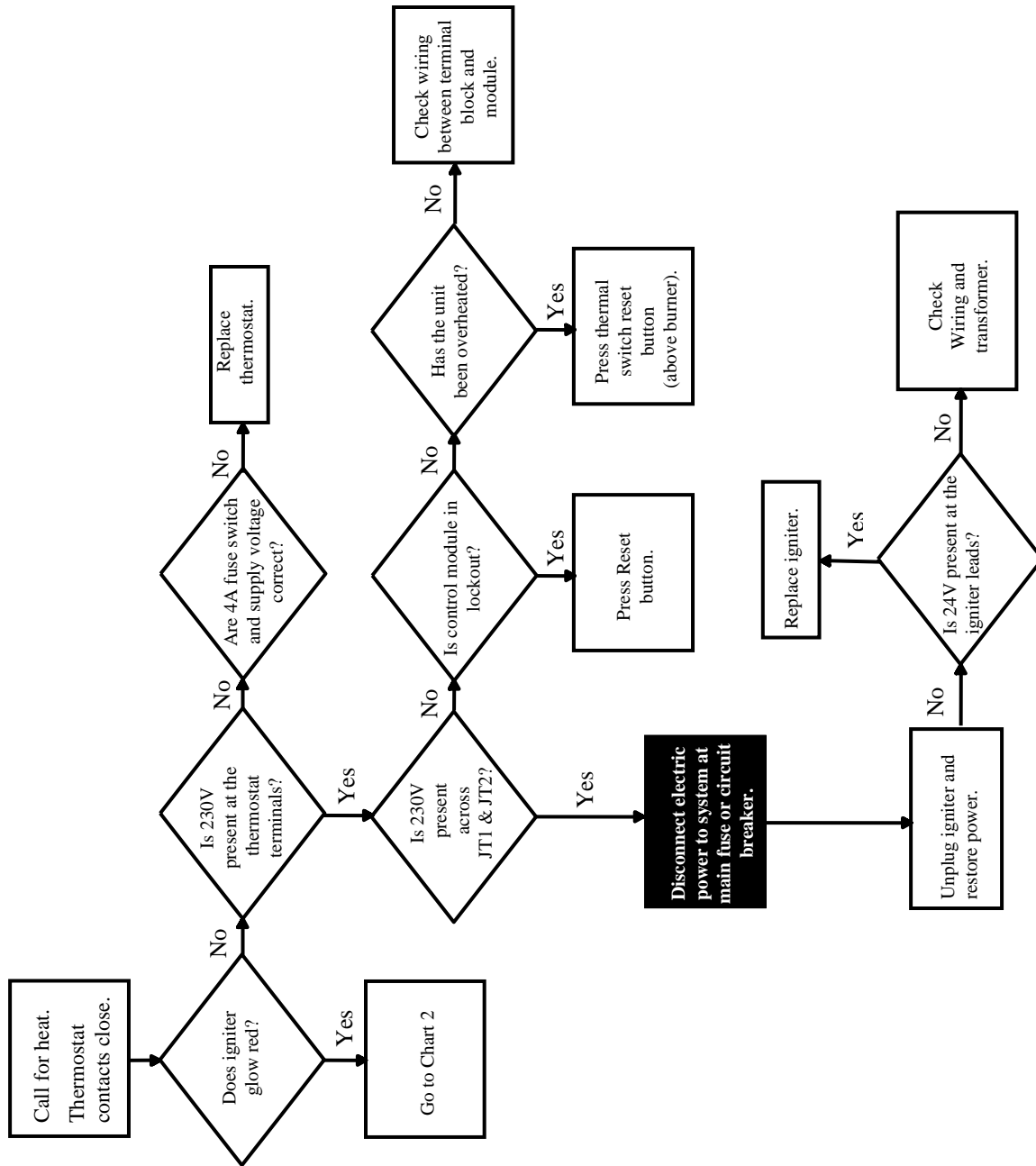

11.3 Chart 2 Second Visual Check

**Chart 2
Second Visual Check**

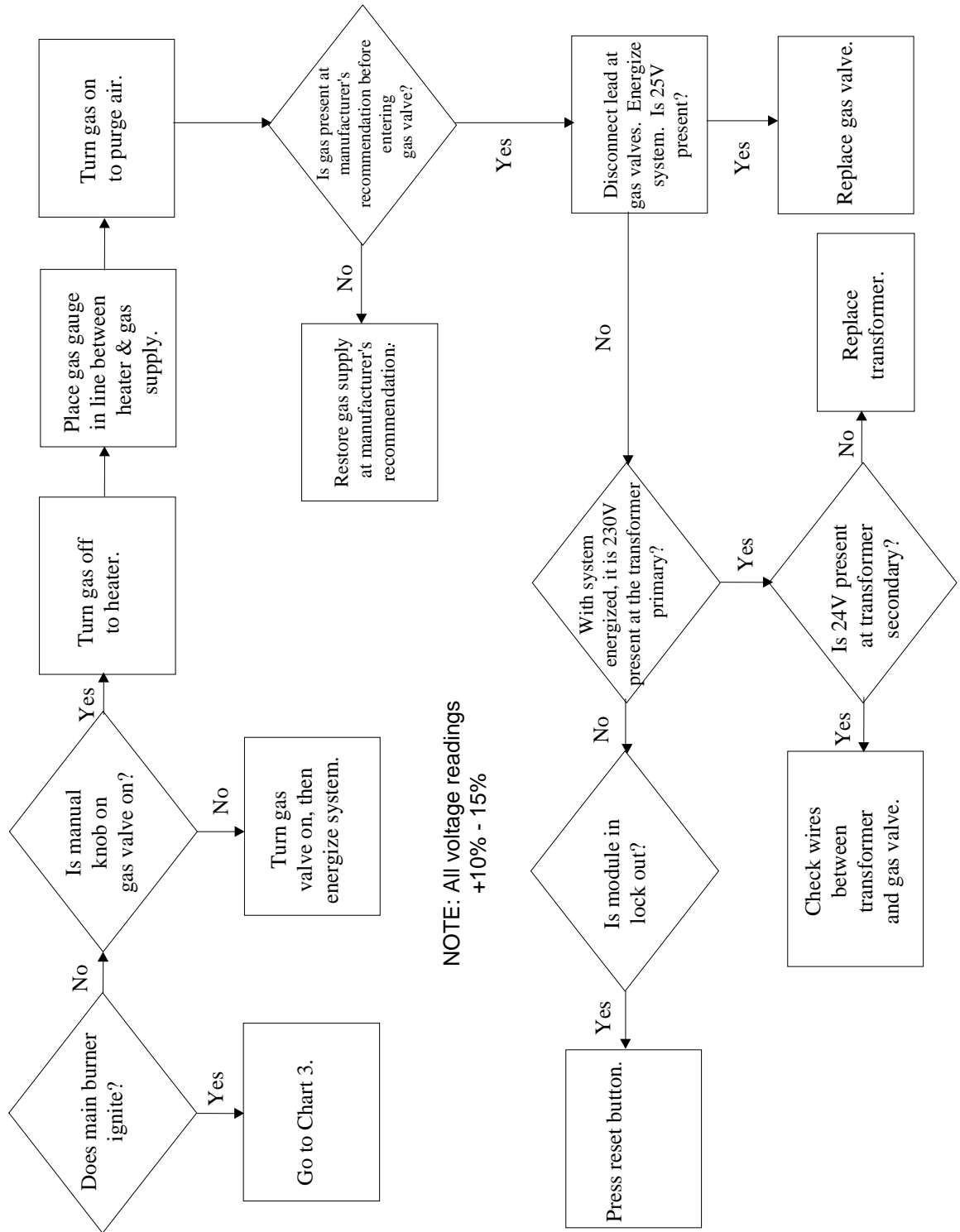

NOTE: All voltage readings +10% - 15%

11.4 Chart 3 Third Visual Check

**Chart 3
Third Visual Check**

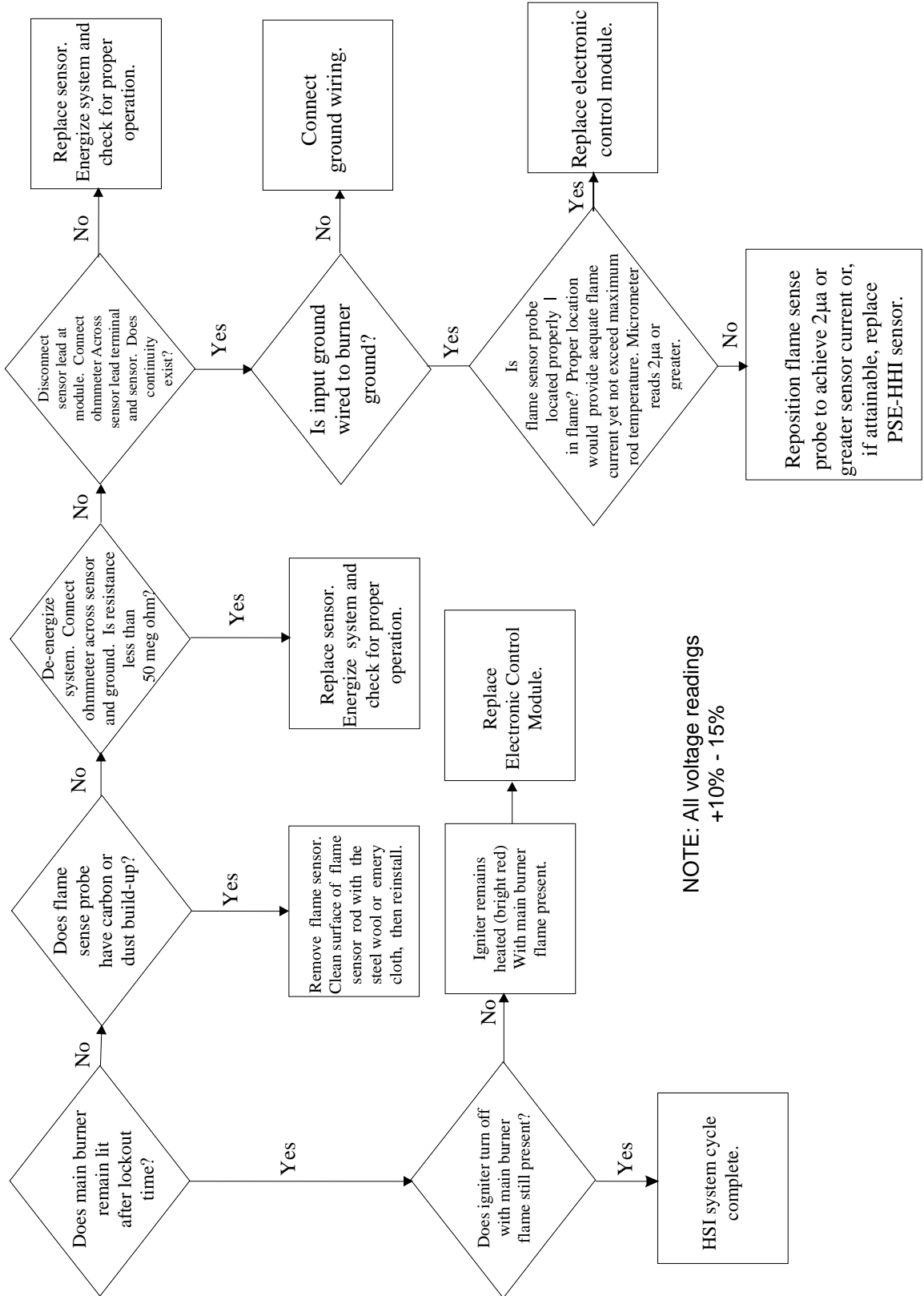

NOTE: All voltage readings +10% - 15%

12. Pipe Sizing For Sufficient Gas Service

THESE GUIDELINES ARE BASED ON THE U. S. STANDARDS.
REFER TO LOCAL AND NATIONAL LAWS AND PRACTICE WHICH MAY SUPERSEDE THE FOLLOWING.

- Using a system schematic, label each piping section of the system starting at the meter or regulator. A different pipe section starts where the gas demand of the system changes, usually at a junction.
- Determine the *Heating Value Required* (HVR) in kWh (kilowatt hours) for each section of pipe. **HVR = (no. of heaters supplied with gas by pipe section) x (heat output per heater)**
- Determine The *Equivalent Length Of Pipe* (ELOP) required for sufficient gas service. **ELOP = (length from gas meter to most remote heater) + (Minor loss equivalents of the system).** **Important:** Use the ELOP value from this equation for size determination of all pipe sections.
- Use the ELOP value from step 3, and the HVR of each pipe section to determine the required pipe size from table 'Maximum Capacity of Pipe' for either Natural Gas (Table 3) or LP (Table 4).

Directions For Reading Pipe Size From Tables:

EXAMPLE: Four 12 kW (40,000 BTUH) heaters will be installed on the gas pipe line as in 'Arbitrary Piping System' diagram.

- Refer to the pipe sections labeled in 'Arbitrary Piping System' diagram below.
- Determine the HVR value of each pipe section of the system.

Pipe Section	# Heaters	HVR Calculation	HVR Value
a-b	4	4 x 12 kW	48 kW
b-c	2	2 x 12 kW	24 kW
c-e	1	1 x 12 kW	12 kW
b-d	1	1 x 12 kW	12 kW
b-f	1	1 x 12 kW	12 kW
c-g	1	1 x 12 kW	12 kW

- Determine ELOP:

Length from meter to most remote heater = length from a to e (or g) = 30 meters (m) + 8 m = 38 m.
 m. Minor loss equivalents from Table 2 = (1 gate valve) x (1m / valve) + (3 tees) x (4 m / tee) = 13 m
 ELOP = 38 m + 13 m = 51 m. Round up to nearest value listed in Table 3: ELOP = 60 m.

Arbitrary Piping System

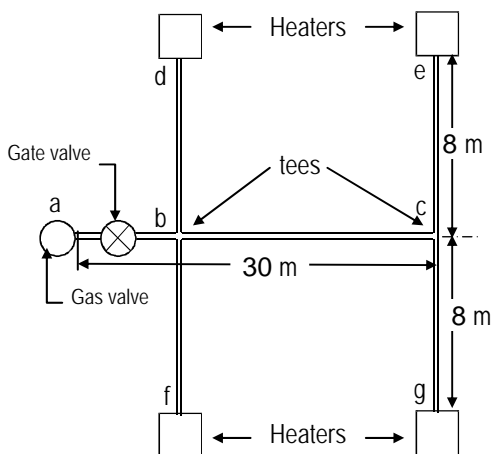

IMPORTANT

Arbitrary piping system diagram is for example only and in no way demonstrates proper heater placement or gas line configurations. Minor loss equivalent values will vary depending upon your system configuration.

Table 2 Minor Loss Equivalents (meters per fitting)

Fitting	52mm IPS Or Smaller	52 mm IPS To 102 mm IPS
45° Elbow	1	2
90° Elbow	2	3
Tee	4	6
Gate Valve	1	1
Angle Valve	9	18
Swing Valve	5	9

4. In the appropriate table, NG (Table 3) or LP (Table 4), select the column showing the ELOP or the next longer length if the table does not give the exact length. Use this column to compare table values to the HVR values. In this example, the Natural Gas (NG) table is selected. From step 3, ELOP = 60 m. Locate the column labeled 60 m in Table 3.
5. Select a pipe section and read down the ELOP column to find the maximum gas capacity that matches the HVR for that pipe section. If the exact figure is not shown, choose the next larger figure in the column. In this example, start with pipe section c-e. For pipe section c-e, HVR = 12 kW. Since 12 kW is not listed, read the next higher value from the table. The next higher value is 21.
6. Follow the row leftward until you reach the column labeled 'Nominal Iron Pipe Size', or 'Internal Diameter', and read the number of the pipe size for the particular pipe section. Example: For pipe section c-e, the iron pipe size is 19.1 mm (3/4 in.) (Table 3: Locate 21 in the 60 m column, read left).
7. Repeat steps 5-6 for each pipe section in the system. Use 60 m column for all readings. Example: The table 'Pipe Sizes Determined For Arbitrary Piping System', summarizes the pipe sizes determined in this example.

IMPORTANT !

Tables 3 and 4 are based on values given in the Gas Engineers Handbook and are intended as a guide only. Consult your gas supplier for gas capacity and pipe size information for your particular piping system.

Pipe Sizes Determined For Arbitrary Piping System			
Pipe Section	HVR Value (from step 2)	Closest value from Table 3	Pipe Size Determined From Table 3
a-b	48	82	31.8 mm (1-1/4 in.)
b-c	24	40	25.4 mm (1 in.)
b-d	12	21	19.1 mm (3/4 in.)
b-f	12	21	19.1 mm (3/4 in.)
c-e	12	21	19.1 mm (3/4 in.)
c-g	12	21	19.1 mm (3/4 in.)

Nominal Iron Pipe Size		Internal Diameter (IPS)		Table 3. Maximum Capacity Of Pipe In kWh (kilowatt hour) Natural Gas (Methane) @ Pressure Drop Of 0.20 mbar (0.08 in. w.c.) Values listed are for 0.6 sp.gr. based on Heat Of Combustion of 10.2 kWh/m ³													
				Length Of Pipe, meters													
m	in.	mm	in.	3	6	9	12	15	18	21	24	27	31	46	60	75	90
12.7	.5	15.8	.622	51	35	28	24	22	19	18	17	15	14	12	10	8	7
19.1	.75	20.9	.824	106	73	59	50	44	40	37	35	32	30	25	21	17	16
25.4	1	26.7	1.05	199	138	110	94	84	76	70	65	60	57	47	40	32	29
31.8	1.25	35.1	1.38	410	278	226	193	170	155	144	135	126	117	95	82	64	60
38.1	1.5	40.9	1.61	615	427	346	290	264	237	220	202	190	182	146	126	95	90
50.8	2	52.6	2.07	1158	806	645	556	492	445	410	380	357	337	278	234	180	175
63.5	2.5	62.7	2.47	1846	1275	1032	879	776	703	659	600	571	542	439	375	283	278
76.2	3	78.0	3.07	3223	2256	1831	1554	1392	1260	1143	1084	1011	952	776	668	544	492
102	4	102	4.03	6741	4630	3751	3195	2843	2579	2374	3198	2110	1964	1611	1348	1109	1005

Nominal Iron Pipe Size		Internal Diameter (IPS)		Table 4. Maximum Capacity Of Pipe In kWh (kilowatt hour) Liquid Propane (LP) @ Pressure Drop Of 0.20 mbar (0.08 in. w.c.) Values listed are for 1.6 sp.gr. based on Heat Of Combustion of 25.8 kWh/m ³												
				Length Of Pipe, meters												
mm	in.	mm	in.	3	6	9	12	15	18	21	24	27	31	38	46	
12.7	.5	15.8	0.622	275	189	152	129	114	103	96	89	83	78	69	63	
19.1	.75	20.9	0.824	567	393	315	267	237	217	196	185	173	162	146	132	
25.4	1	26.6	1.049	1071	732	590	504	448	409	378	346	322	307	275	252	
31.8	1.25	35.0	1.380	2205	1496	1212	1039	913	834	771	724	677	630	567	511	
38.1	1.5	40.9	1.610	3307	2299	1858	1559	1417	1275	1181	1086	1023	976	866	787	
50.8	2	52.5	2.067	6221	4331	3465	2992	2646	2394	2205	2047	1921	1811	1606	1496	

13. Parts & Assemblies

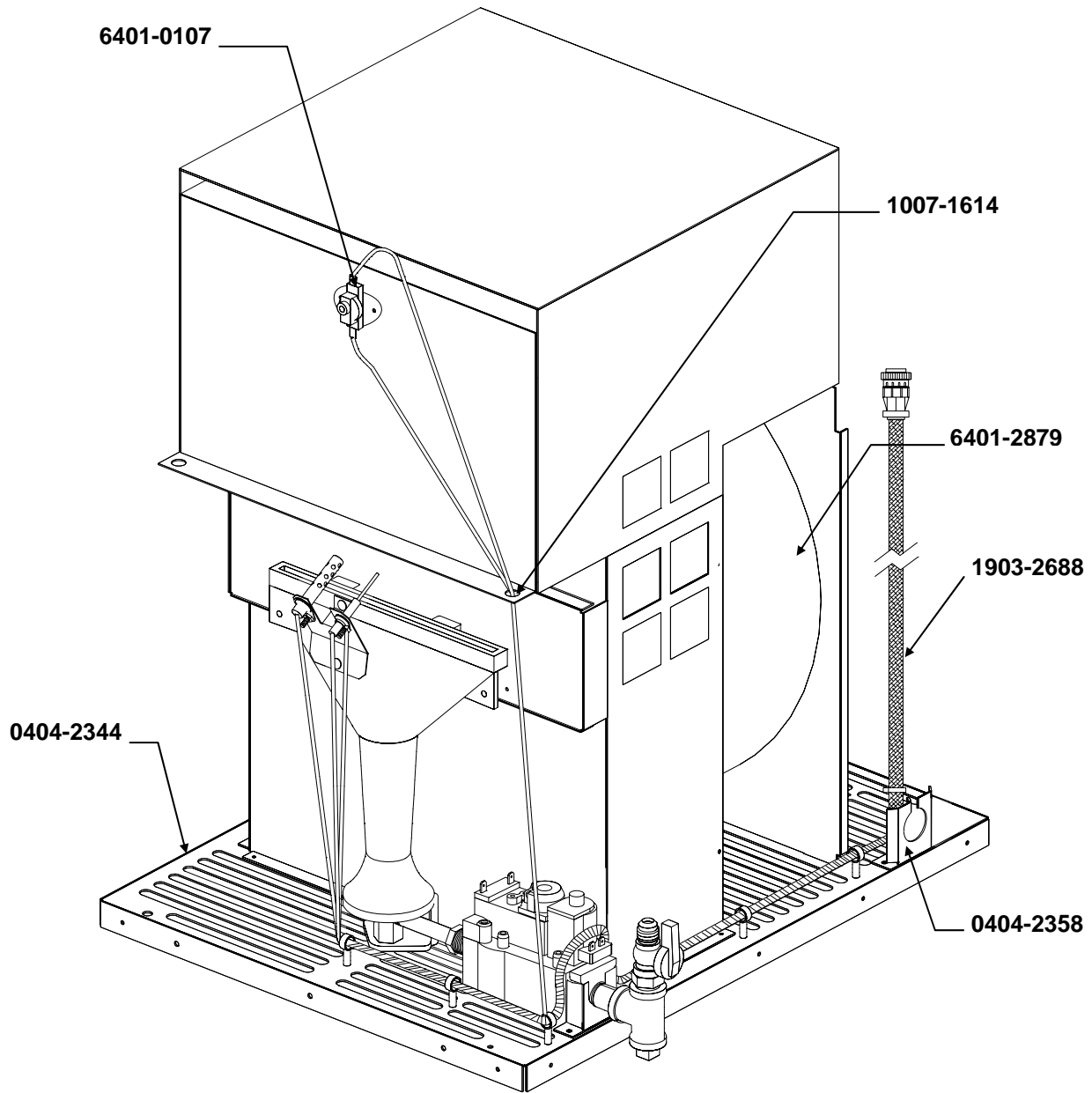

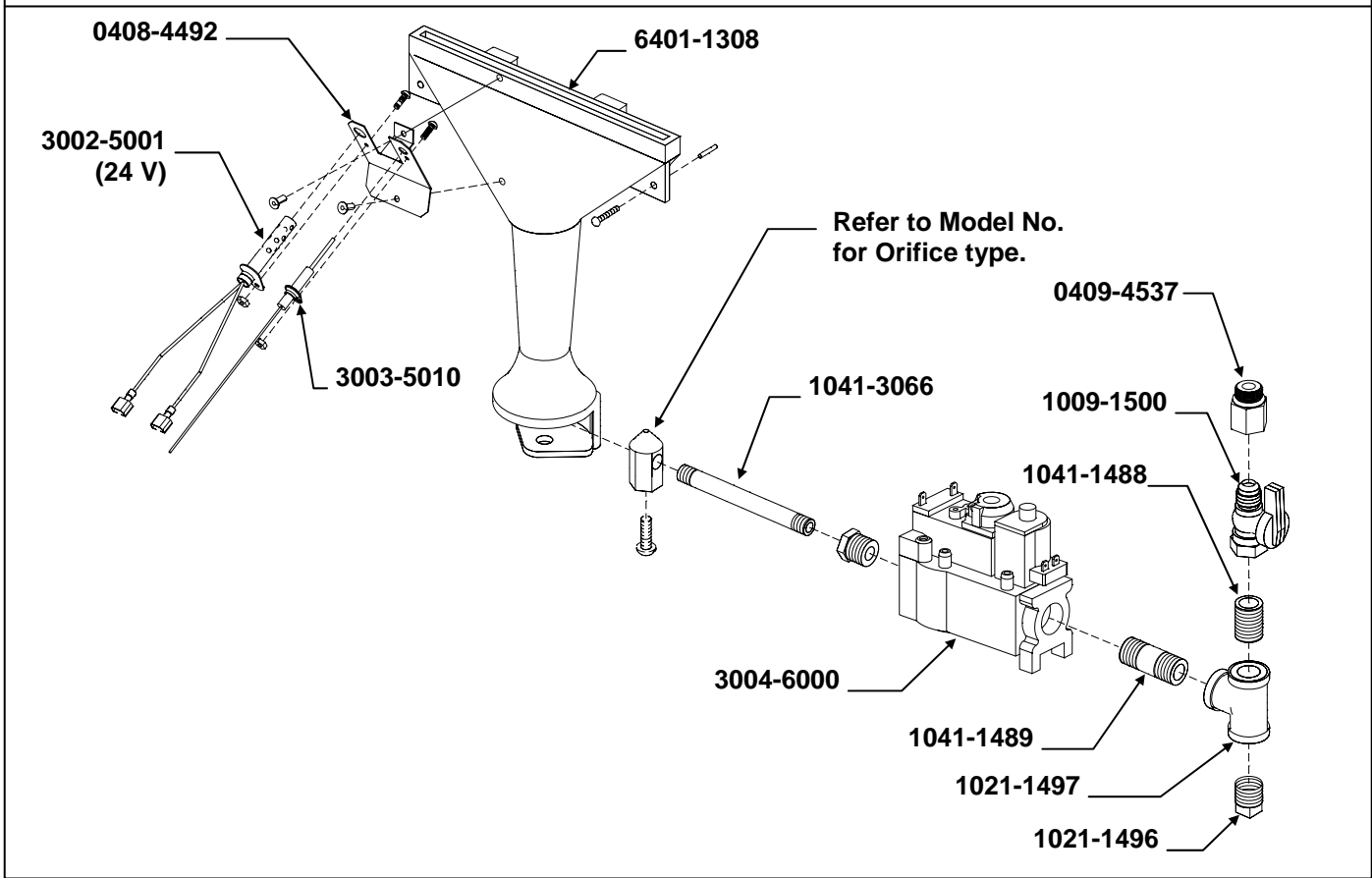
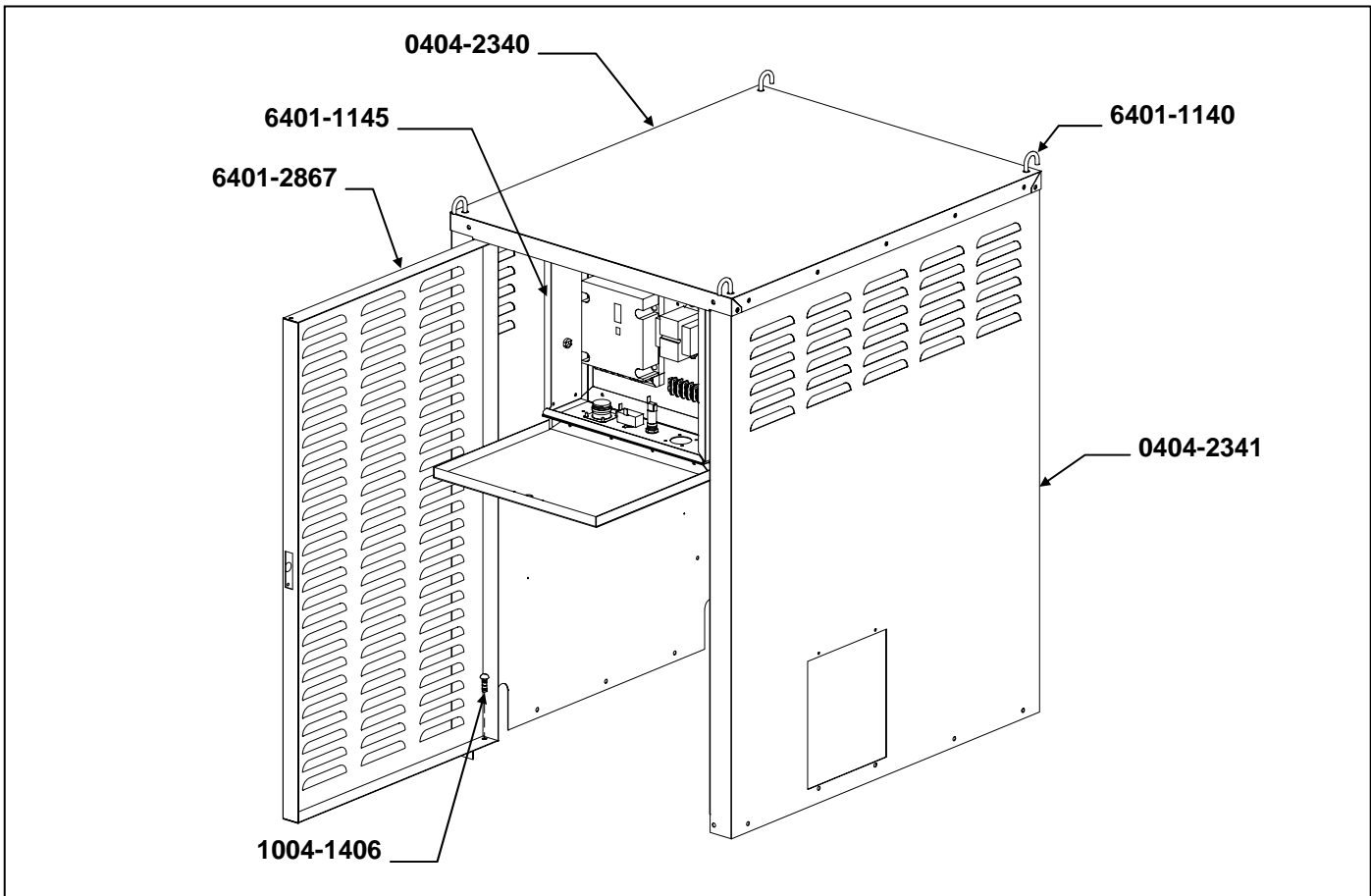

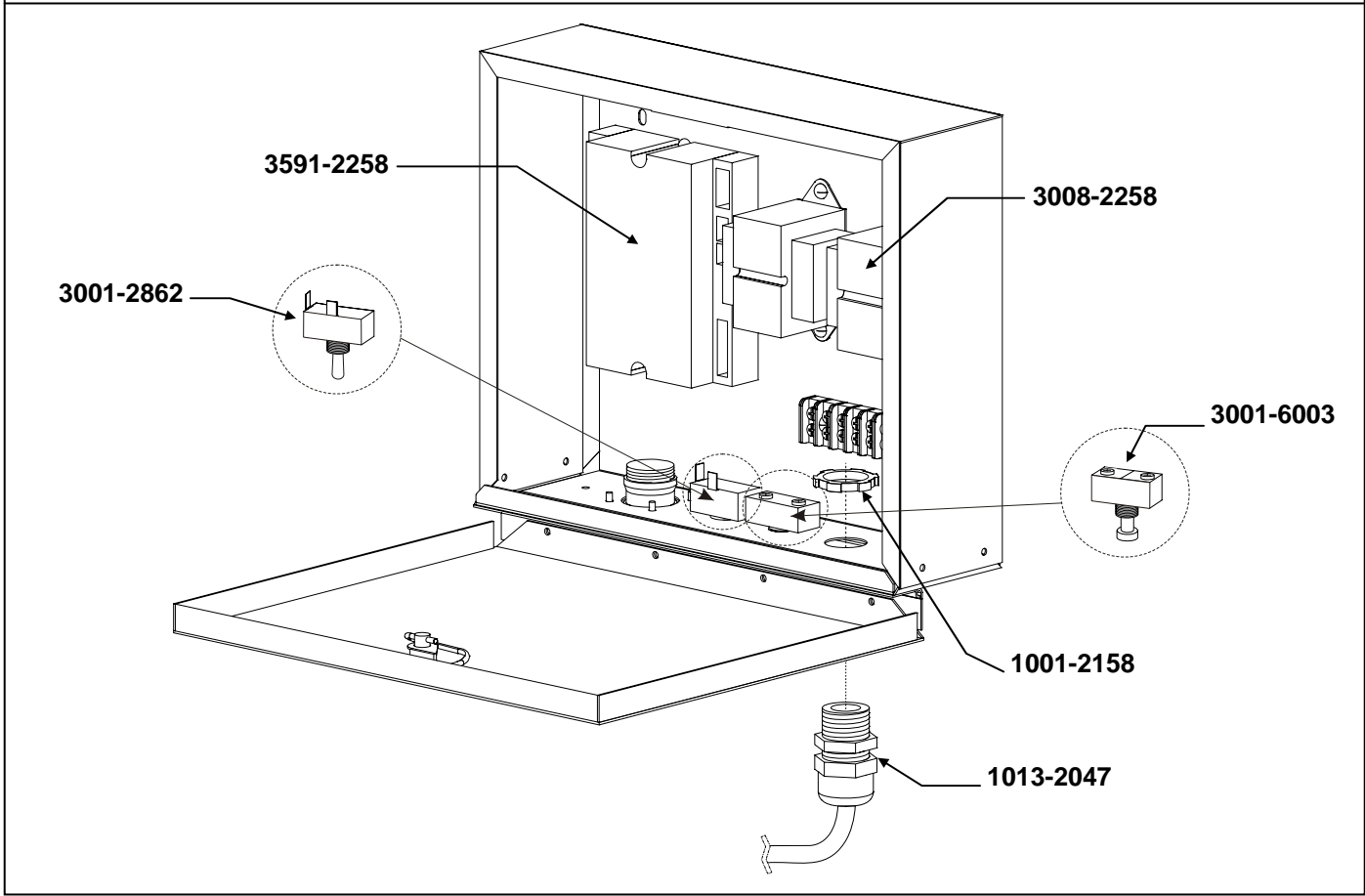
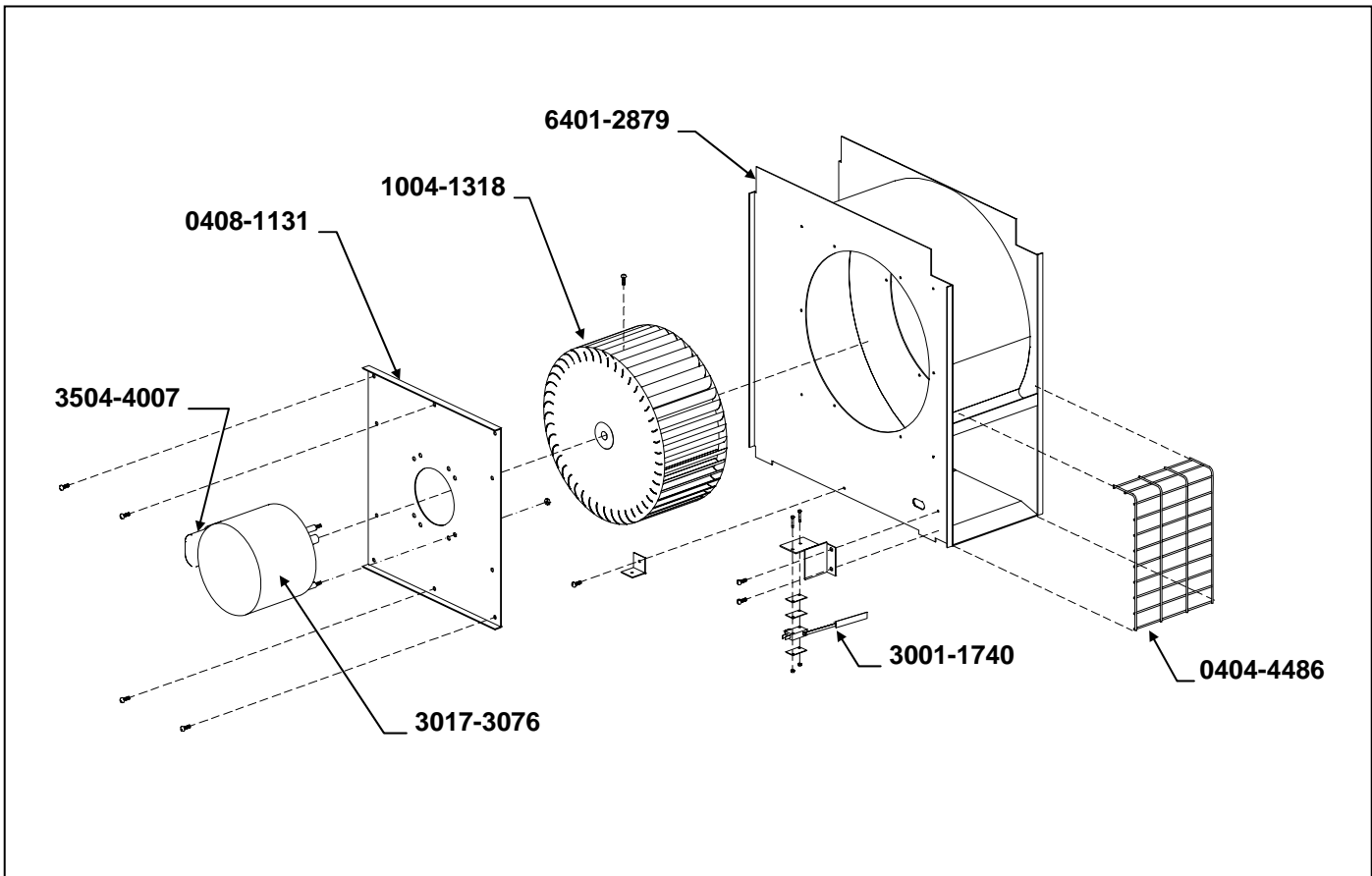



HIRED-HAND®

PARTS LIST

When Ordering Service Parts, Please Reference Model Number And Gas Type.

Ref. Number	Description	Ref. Number	Description
3005-0107	High Limit Thermo-Disc 160°C (320°F)	3001-2862	Toggle Switch
1007-1614	¼ Strain Relief	6404-2867	Door Assembly
1903-2688	Lg Heater Wiring Harness 230V, 50/60 Hz	3016-3076	Motor, 1/3 Hp, 230v
6401-1147	Galvanized Control Plate, 230v, 50/60 Hz	0408-4492	Mounting Bracket
3002-5001	24V Igniter Used For 230v, 50/60 Hz	3001-6003	Push Button Switch
3003-5010	1.25 Flame Sense Probe	3591-2258	Control Module
1041-3066	¼ x 4-½ Pipe Nipple	0409-4537	CE Heater BSPP Adapter
1009-1500	½ x ½ Brass Ball Valve		
1041-1488	½ Close Pipe Nipple		
1021-1496	½ Pipe Plug		
1041-1491	½ x 2 Pipe Nipple		
3001-2862	Single-Pole Throw (On/Off)		
3001-1740	Sail Switch		
0404-4486	Outlet Finger Guard		
0409-3001	Orifice, Butane/Propane		
0409-3002	Orifice, Propane		
0409-3006	Orifice, Natural Gas		
0404-2358	Cord Connector Support		
0404-2344	Panel Cabinet Bottom		
0408-1131	Motor Mount		
6401-1318	Blower Wheel		
6401-2879	Blower Housing		
0408-1315	Baffle Inlet		
6401-1145	Enclosure For Control Plate		
0404-2340	Cabinet Top Panel		
0404-2341	Cabinet Front Panel		

Copyright © 2008 by  Group
Printed in the USA