

# Curtain Controller

*Featuring the Enclosed Limit Switch and Pulley Covers*

## Installation and Operation Manual

PNEG-620-2

Date: 01-11-12



**Intertek**



PNEG-620-2



BY THE

**GSI GROUP**



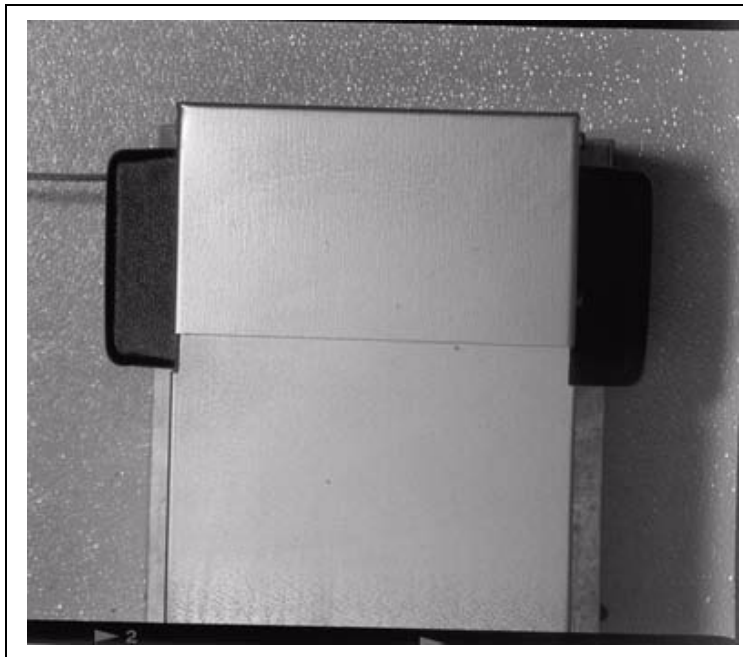

**This equipment shall be installed in accordance with the current installation codes and applicable regulations which should be carefully followed in all cases. Authorities having jurisdiction should be consulted before installation occurs.**

## Contents

<b>Chapter 1 Safety</b> .....	<b>4</b>
Safety Guidelines .....	4
General Safety Statement .....	5
<b>Chapter 2 Safety Decals</b> .....	<b>7</b>
<b>Chapter 3 Installation</b> .....	<b>8</b>
<b>Chapter 4 Header Pulley</b> .....	<b>10</b>
Cable Configurations .....	10
<b>Chapter 5 Pulley Cover Mounting</b> .....	<b>11</b>
Pulley Cover Mounting Instructions .....	11
<b>Chapter 6 Maintenance</b> .....	<b>12</b>
<b>Chapter 7 Troubleshooting Guide</b> .....	<b>13</b>
<b>Chapter 8 Parts List</b> .....	<b>14</b>
Enclosed Limit Switch Assembly .....	14
Motor Components .....	16
<b>Chapter 9 Installation Kit</b> .....	<b>20</b>
AC180-A Installation Kit (Purchased Separately) .....	20
AC180-B Installation Kit (Purchased Separately) .....	21
<b>Chapter 10 Wall Mount</b> .....	<b>23</b>
Outside Endwall Mount .....	23
Outside Sidewall Mount .....	24
Inside Endwall Mount .....	25
<b>Chapter 11 Wiring Diagrams</b> .....	<b>26</b>
Potentiometer Wiring Diagram .....	26
Control Box Wiring .....	27
Wiring Diagram for 110V 60 Hz .....	28
Wiring Diagram for 220V 50/60 Hz .....	29
<b>Chapter 12 Warranty</b> .....	<b>31</b>

### Safety Guidelines

This manual contains information that is important for you, the owner/operator, to know and understand. This information relates to protecting **personal safety** and **preventing equipment problems**. It is the responsibility of the owner/operator to inform anyone operating or working in the area of this equipment of these safety guidelines. To help you recognize this information, we use the symbols that are defined below. Please read the manual and pay attention to these sections. Failure to read this manual and its safety instructions is a misuse of the equipment and may lead to serious injury or death.



**This is the safety alert symbol. It is used to alert you to potential personal injury hazards. Obey all safety messages that follow this symbol to avoid possible injury or death.**



**DANGER** indicates a hazardous situation which, if not avoided, will result in death or serious injury.



**WARNING** indicates a hazardous situation which, if not avoided, could result in death or serious injury.



**CAUTION**, used with the safety alert symbol, indicates a hazardous situation which, if not avoided, could result in minor or moderate injury.



**NOTICE** is used to address practices not related to personal injury.

### General Safety Statement

Our foremost concern is your safety. This manual is to help you understand safe operating procedures and some problems that may be encountered by the operator and other personnel.

As owner and/or operator, you are responsible to know what requirements, hazards, and precautions exist and inform all personnel associated with the equipment or in the area. Safety precautions may be required from the personnel. Avoid any alterations to the equipment, which may produce a very dangerous situation, where SERIOUS INJURY or DEATH may occur.

### Electrical Safety

An adequate and safe power supply to the Curtain Controller unit is essential for safety. A competent and qualified electrician must undertake all electrical wiring. All wiring is to be installed according to the National Standards and Regulations relevant to your Country and Region.

Be sure to properly ground all motors and electrical equipment employed. Permanent wiring must be employed if required by local codes. Permanent wiring must also be installed according to applicable local codes.

### User's Manual

This manual contains information and instructions essential to the safe installation and use of the Curtain Controller System. Read this manual thoroughly **before** attempting any installation or use of the Curtain Controller System. Keep this manual with the Curtain Controller System or in a location where it can be readily accessed. Failure to read this manual and its safety instructions is a misuse of the equipment.

### Correct Uses of Your Curtain Controller

The Curtain Controller System is designed solely for the purpose of controlling temperature curtains in livestock (swine and chicken) houses. Use of the system in any other way is a misuse of the system and may endanger safety and health.

Only genuine AP/Cumberland parts are to be used in the installation and use of the Curtain Controller System. Use of other non-genuine parts is a misuse of the system and may lead to dangerous situations imperilling the safety and health of you and others.

### Controls

The Curtain Controller is designed for use with manual or automatic temperature control. GSI recommends the use of genuine GSI controls. Use of any controllers that do not meet this specification can pose a risk to health and safety and will lead to malfunction and failure of the Curtain Controller.

This machine is not designed for use in atmospheres where there is a risk of explosion. Use of the Curtain Controller System in such an environment is prohibited. If in doubt, contact your dealer or GSI.

### Safety Guards

The Curtain Controller System contains many moving and electrical parts, which will cause serious injury or death if touched. Guards are placed on the machine for your protection. Operating the machine at any time with guards removed or incorrectly fitted is a serious misuse of the machine and endangers safety.

## 1. Safety

### Safety in Handling the Curtain Controller System

The Curtain Controller unit weights:

Model #	Weight
CC2415	104 lbs./47 kg
CC2430	
CC2460	
I2430-50	
CC3615	119 lbs./54 kg
CC3630	
CC3660	
I3630-50	
CC4815	135 lbs./61 kg
CC4830	
CC4860	
I4830-50	
CC6015	151 lbs./69 kg
CC6030	
CC6060	
I6030-50	

All precautions should be taken when lifting and/or moving the unit, to prevent the risk of physical injury.

### Maximum Load

The Curtain Controllers with 15 RPM and 30 RPM gear motors can lift a maximum of 4000 lbs./1814 kg at a 2:1 pulley ratio. 60 RPM Gear motors can lift a maximum of 1000 lbs./453 kg at a 2:1 pulley ratio.

### Safety in Maintenance

While the Curtain Controller is designed to keep maintenance to a minimum, some maintenance will be necessary in the course of the life of the machine. Do not attempt any repairs on the machine unless you are competent to do so. Remember that the Curtain Controller may operate under automatic control and start without warning. Never attempt any work on the Curtain Controller without first isolating the machine from the main power and locking the isolator so that only you can turn the power back ON.

Follow all guidelines given in the maintenance section on [Page 12](#) of this manual.

Before restarting the Curtain Controller, ensure that all electrical enclosures are locked closed and all guards and other safety measures are correctly fitted.

If in any doubt, contact your dealer or GSI for assistance.

### Noise

Tests on this machine indicate noise levels at a position one meter from the drive unit, and 1.6 meters above the ground do not exceed 70 dBa, continuous "A" weighted sound pressure or 63 Pa, instantaneous "C" weighted sound pressure.

This page shows you exactly where the safety signs should be placed on your Curtain Controller. If a decal is missing, damaged or unreadable, please contact your dealer or the GSI group, for a free replacement.

For guidance or assistance on any issues relating to the safe use of the Curtain Controller System,

**Contact:**

**GSI Group**

1004 E. Illinois St.  
Assumption, IL. 62510  
Phone: 1-217-226-4421



DC-1948 is located above the electrical box on the outside of the Curtain Controller.

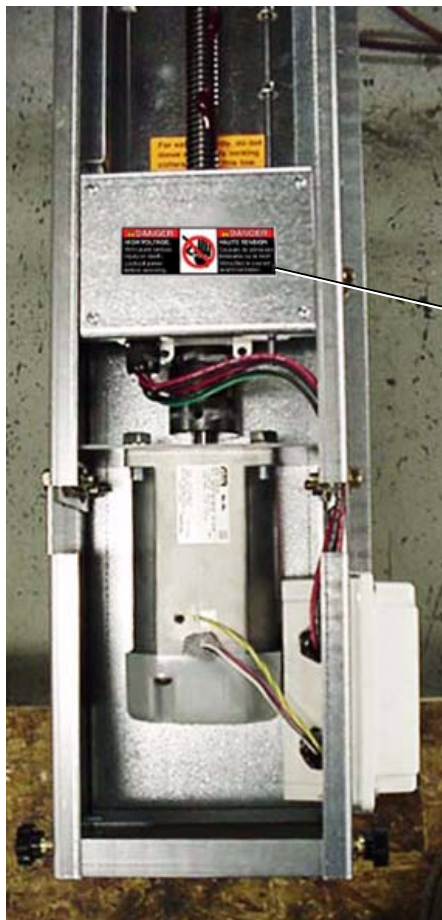

DC-1948 is located on the electrical unit within the Curtain Controller.



### 3. Installation

This manual outlines the recommended sequence for the installation of the Curtain Controller system. The curtain controller may be installed either inside or outside. Following the sequence will prove the safest and easiest method of installation. Above all, connection of the system to the electrical mains should be the final stage of installation. Failure to observe this could lead to a fatal accident.

1. Unpack the Curtain Controller, remove the front cover and inspect the machine for visible defects.
2. Select mounting configuration. (See examples of: wall mount on [Pages 23-25](#).)
3. Screw one 3/8" x 3" lag bolt 6-1/2" below the desired height of the Curtain Controller.  
**NOTE:** Leave 1-1/2" between the bolt head and the wall. (See [Figure 3A](#).)

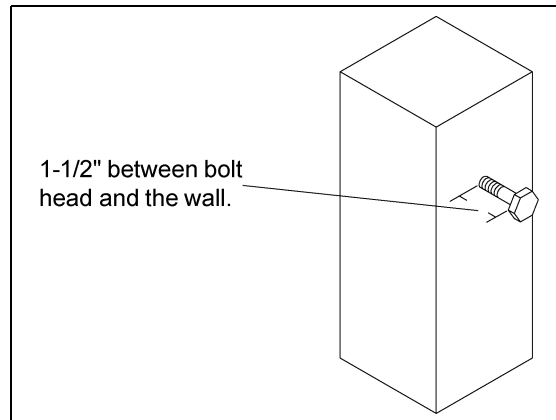

**Figure 3A**

4. Using the "keyhole" slot in the back of the Curtain Controller, hang the machine on the 3" lag bolt. (See [Figure 3B](#).) **NOTE:** The 3" lag bolt should only be used to hang the machine to the wall. Do not attempt to operate the machine until it is fully secured.

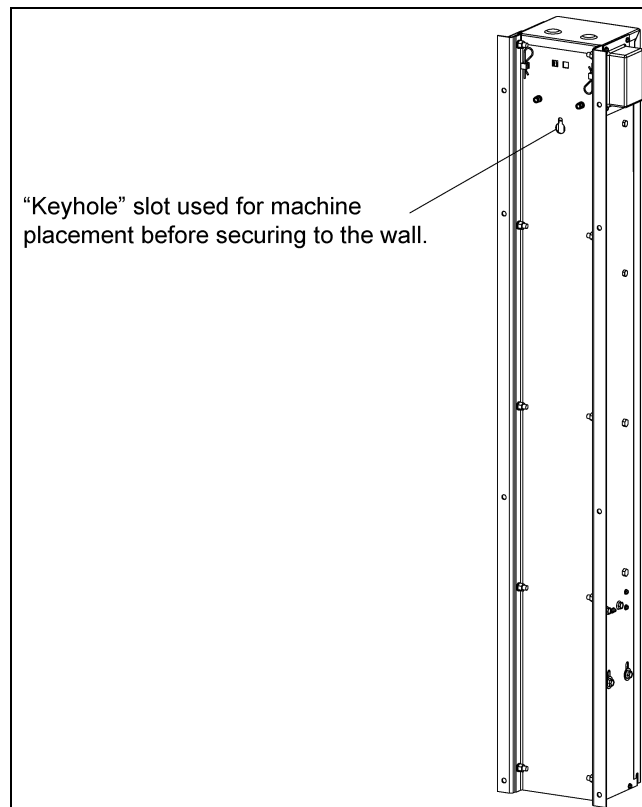

**Figure 3B**

5. Secure the machine to the wall by using the six (6) 3/8" x 2" lag bolts provided. (See Figure 3C.)

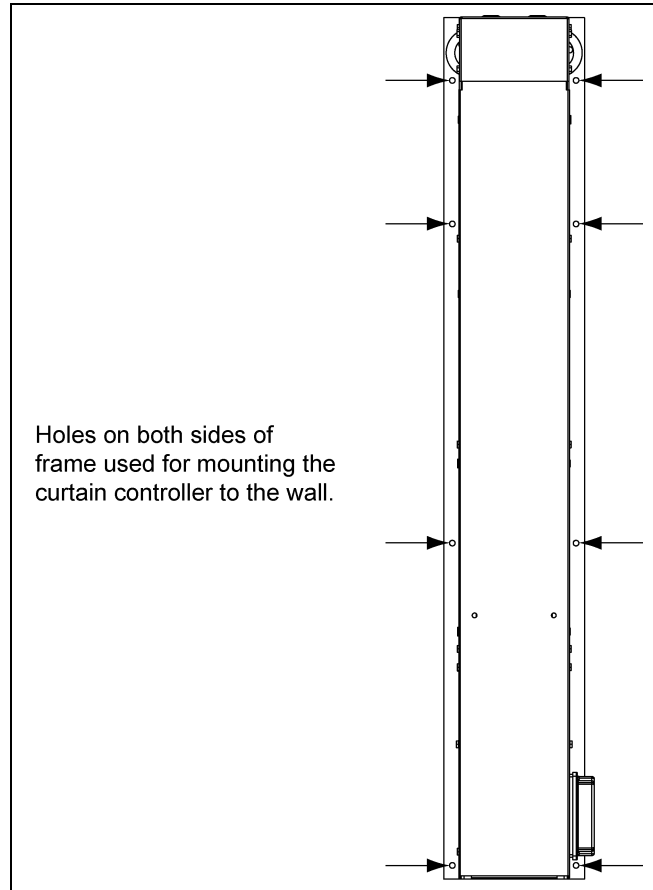

Figure 3C

6. Install pulleys, brackets, hand winches etc., according to the appropriate mounting configuration.
7. Install the cabling through the pulleys, brackets, hand winches etc., according to appropriate mounting configuration. Recommended cable size is 3/16".
8. Install the cable into the Curtain Controller pulley cover and loop the cable around the pulley.
9. While the drive block is near the closed position (bottom of the drive screw), loop the incoming cable through the U-bolt and fasten the cable to itself using three (3) 3/16" cable clamps per cable.
10. Wire the Curtain Controller to the appropriate control. (See wiring diagrams on [Pages 26-29](#).)



**Be sure to properly ground all motors and electrical equipment.**

11. Close the curtains/vents fully using the manual mode of the controls. Set the lower limit using the lower limit adjustment collar. **NOTE:** Be sure to tighten the limit switch adjustment collar. Failure to do so can cause damage to the machine and barn. Take up excess slack in the cable using the manual winch while paying close attention not to overtighten.
12. Open the curtains/vents to the desired height using the manual mode of the controls. Set the upper limit switch adjustment collar. **NOTE:** Be sure to tighten the limit switch adjustment collar. Failure to do so can cause damage to the machine and barn.
13. Attach the door to the machine. This will protect the integrity of the machine and ensure the safety of those working on or near the machine.

## 4. Header Pulley

### Cable Configurations

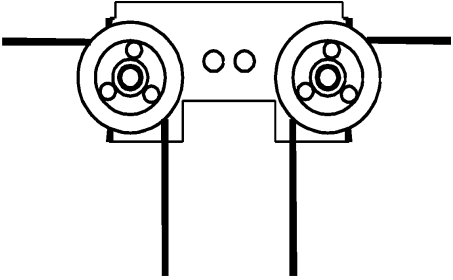
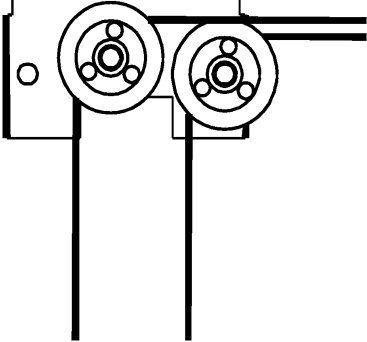
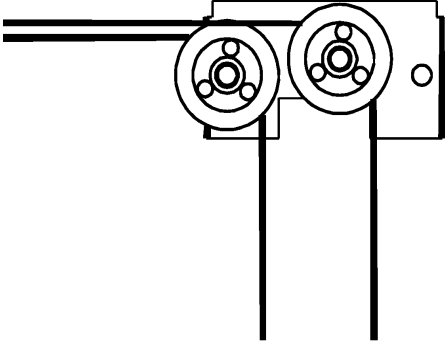
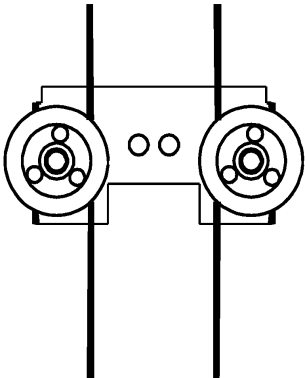
Pulley Configuration(s)	Used when
	<p>Pulling two (2) curtains with the Curtain Controller.</p>
	<p>Pulling one curtain to the right of the Curtain Controller.</p>
	<p>Pulling one curtain to the left of the Curtain Controller.</p>
	<p>Curtain Controller is mounted horizontally. Remove the cap plugs in the top of the machine and run cables through the top holes.</p>

## Pulley Cover Mounting Instructions

### Attaching Pulley Covers to Pre-Existing Cable

**NOTE:** If you do not have pre-existing cable, drill a 1/4" hole in the appropriate dimple and proceed to [Step 4](#).

**Step 1:** Determine on which side of the machine the pulley cover will be mounted. This will affect where the slot will be cut in [Step 2](#).

**Step 2:** Using a saw, cut a slot from the bottom of the pulley cover lip to the dimple on the cover's face. When slotting the right pulley cover, use the right dimple for placement. When slotting the left pulley cover, use the left dimple for placement. (See [Figure 5A](#) for slot placement.)

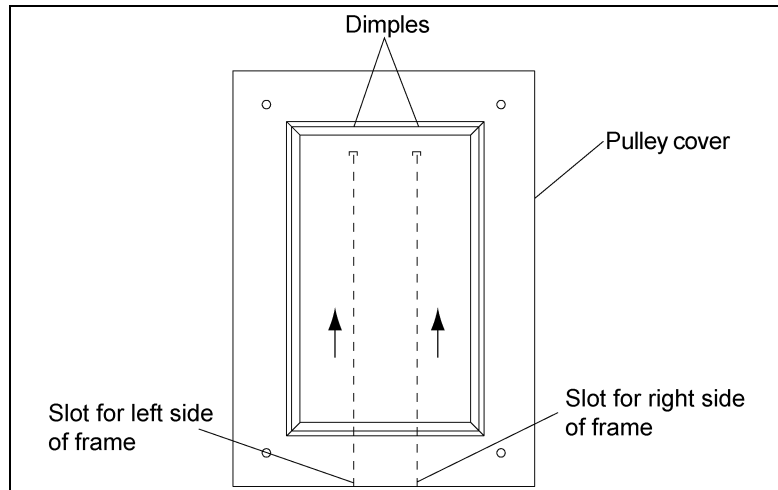

Figure 5A

**Step 3:** Slide the existing cable into the slot until it reaches the dimple.

**Step 4:** Remove existing sheet metal screw. (See [Figure 5B](#) for pulley cover fastening.)

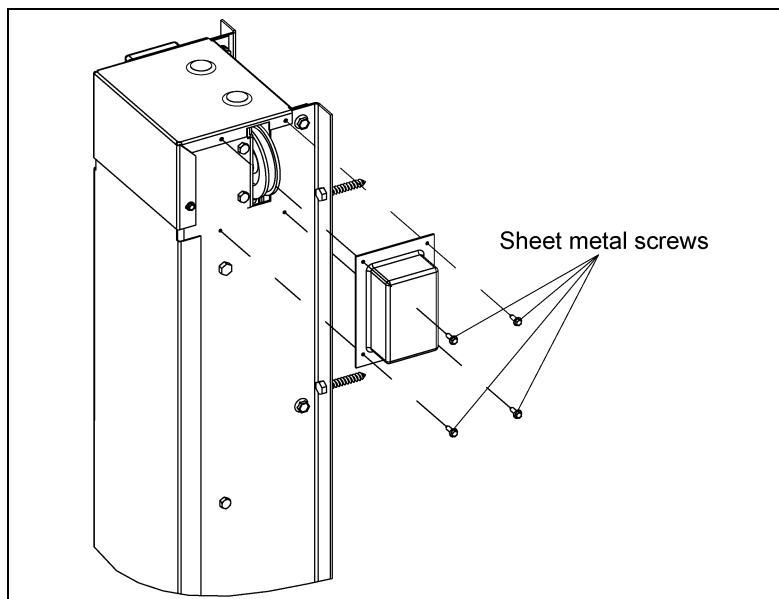

Figure 5B

**Step 5:** Fasten the pulley cover to the machine using four (4) #10-16 x 5/8" sheet metal screws. The top of the pulley cover should be flush with the top of the machine.

## 6. Maintenance

---

### Safety in Maintenance and Repairs

Before starting any repairs or maintenance on the Curtain Controller System or control units, observe the following safety steps:

1. Isolate the system from the electricity supply by switching OFF the power isolator and lock it in the OFF position.
2. Keep the key in your possession.
3. Do not reconnect the power supply until all work is completed and all guards are correctly refitted.

It is recommended that the end user practices a monthly inspection of the Curtain Controller and all items used in conjunction (cables, pulleys, brackets, hand winches etc.) with the machine.

1. Inspect the drive screw. Lubricate liberally with a lithium grease of an NLGI No. 2 consistency (extreme pressure properties).
2. Inspect and tighten the locking collars on the adjustment rod to ensure activation of limit switches.
3. Inspect cable, pulleys, brackets, hand winches etc., for alignment and premature wear. Realign and/or replace as needed.
4. Inspect bearings checking for smooth rotation and listening for squeaks.
5. Inspect set screws in couplers and in pillow block bearing.
6. Manually run machine in both directions to ensure positive shut off and unrestricted cable movement.
7. Inspect drive screw for debris in the threads. Debris in threads may cause premature failure of drive block.
8. Inspect the thrust bearing. Lubricate as needed.

## 7. Troubleshooting Guide

Problem	Possible Cause	Corrective Action
1. Will not run in manual mode.	<ol style="list-style-type: none"> <li>Control not in manual mode.</li> <li>Toggle switch failure.</li> </ol>	<ol style="list-style-type: none"> <li>Move switch to manual setting. Check for loose wire connection.</li> <li>Replace toggle switch.</li> </ol>
1. Machine operates in opposite direction in response to temperature change.	<ol style="list-style-type: none"> <li>Control wired incorrectly.</li> </ol>	<ol style="list-style-type: none"> <li>Re-wire to wiring schematic instruction.</li> </ol>
<ol style="list-style-type: none"> <li>Runs in both directions (automatic mode), but only one direction (manual mode).</li> <li>Will not run in either direction (manual or automatic modes).</li> </ol>	<ol style="list-style-type: none"> <li>Control failure.</li> <li>No power (circuit breaker or fuse).</li> <li>Tripping may indicate machine overload or electrical wire short. Repair or replace before reenergizing circuit.</li> <li>Motor failure.</li> <li>Primary switch failure.</li> </ol>	<ol style="list-style-type: none"> <li>Check for loose wire connection.</li> <li>Replace control.</li> <li>Check main panel circuit breaker or fuse.</li> <li>Check control circuit breaker and/or fuse.</li> <li>Motor designed with internal thermal protection. Before replacing, allow motor to cool down and reset. May indicate machine overload. Contact factory for machine restrictions.</li> <li>Replace primary switch.</li> <li>Check to see if secondary switch is not depressed.</li> </ol>
1. Will not run in automatic but <b>does</b> operate in manual.	<ol style="list-style-type: none"> <li>Control not in automatic mode.</li> <li>Control failure</li> </ol>	<ol style="list-style-type: none"> <li>Move switch to automatic setting.</li> <li>Replace control.</li> </ol>
1. Runs in one direction only, both automatic and manual.	<ol style="list-style-type: none"> <li>Broken or loose wire.</li> <li>Limit switch catching on adjustment rod mechanism.</li> <li>Limit switch failure.</li> <li>Control failure.</li> </ol>	<ol style="list-style-type: none"> <li>Repair broken or loose wire.</li> <li>Free switch and adjust as needed.</li> <li>Replace switch.</li> <li>Replace control.</li> </ol>

# Enclosed Limit Switch Assembly

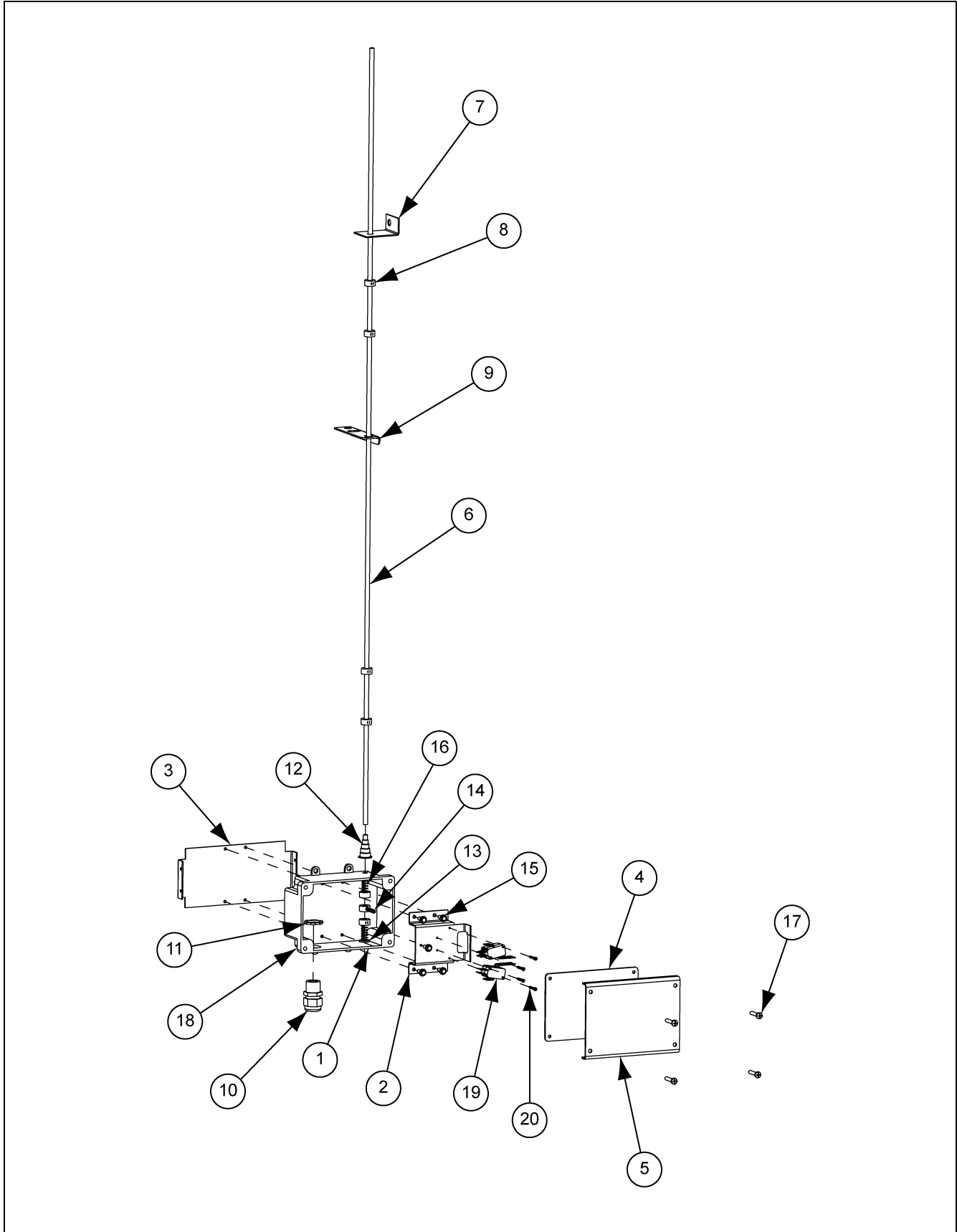

## Enclosed Limit Switch Assembly Parts List

Ref #	Part #	Description
1	52-0323	Limit Switch Box
2	52-0319	Bracket, Limit Switch Support
3	52-0320	Channel, Electrical Box Mounting 4" x 6"
4	52-0322	Gasket, Flat 4" x 6" Box
5	52-0318	Lid 4" x 6" Flat
6	50-0144	24" Travel Adjustment Rod
6	50-0145	36" Travel Adjustment Rod
6	50-0146	48" Travel Adjustment Rod
6	50-0147	60" Travel Adjustment Rod
7	52-0321	Adjustment Rod Retainer 4" x 6"
8	50-0159	Adjustment Collar
9	52-0171	Angle, Limit Actuator
10	FH-1310	Cord Connector, Heyco
11	FH-1309	Lock Nut 1/2" #401 ARL.
12	52-0331	Water Shield
13	S-2126	1/4" SAE Washer
14	S-7967	Set Screw #10-32 x 1-1/4"
15	S-280	Screw, SDS #10-16 x 5/8" HWH ZN
16	52-0170	Spring, Adjustment Rod Extension
17	S-7377	Screw, MS #10-24 x 1" RHP ZN Grade 2
18	S-849	Hex Nut #10-24 ZN Grade 2
19	S-7974	Straight Actuator Micro Switch
20	S-8810	Screw, SMSAB #4 x 1" PHP ZN



Motor Components (Continued)

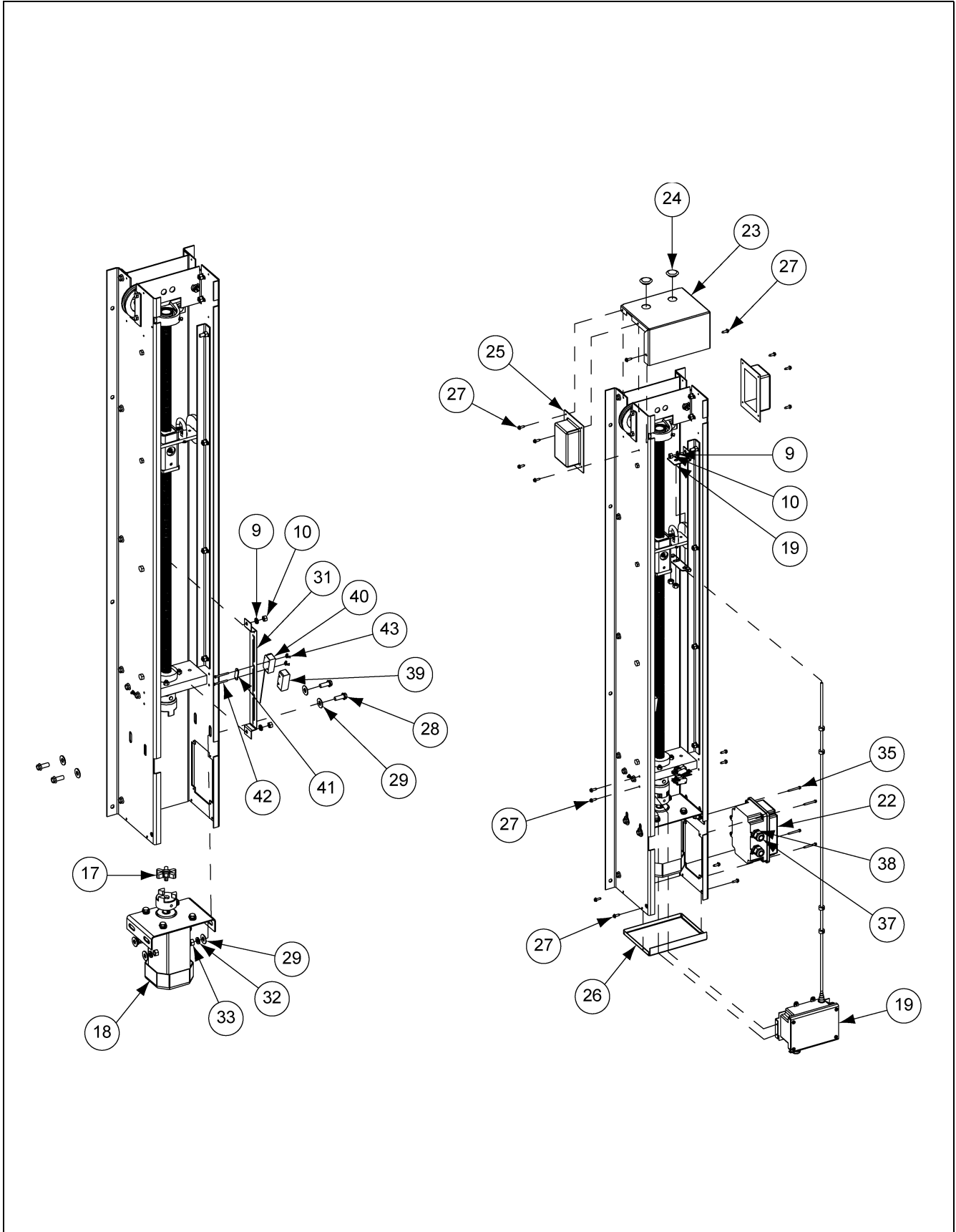

# Motor Components (Continued)

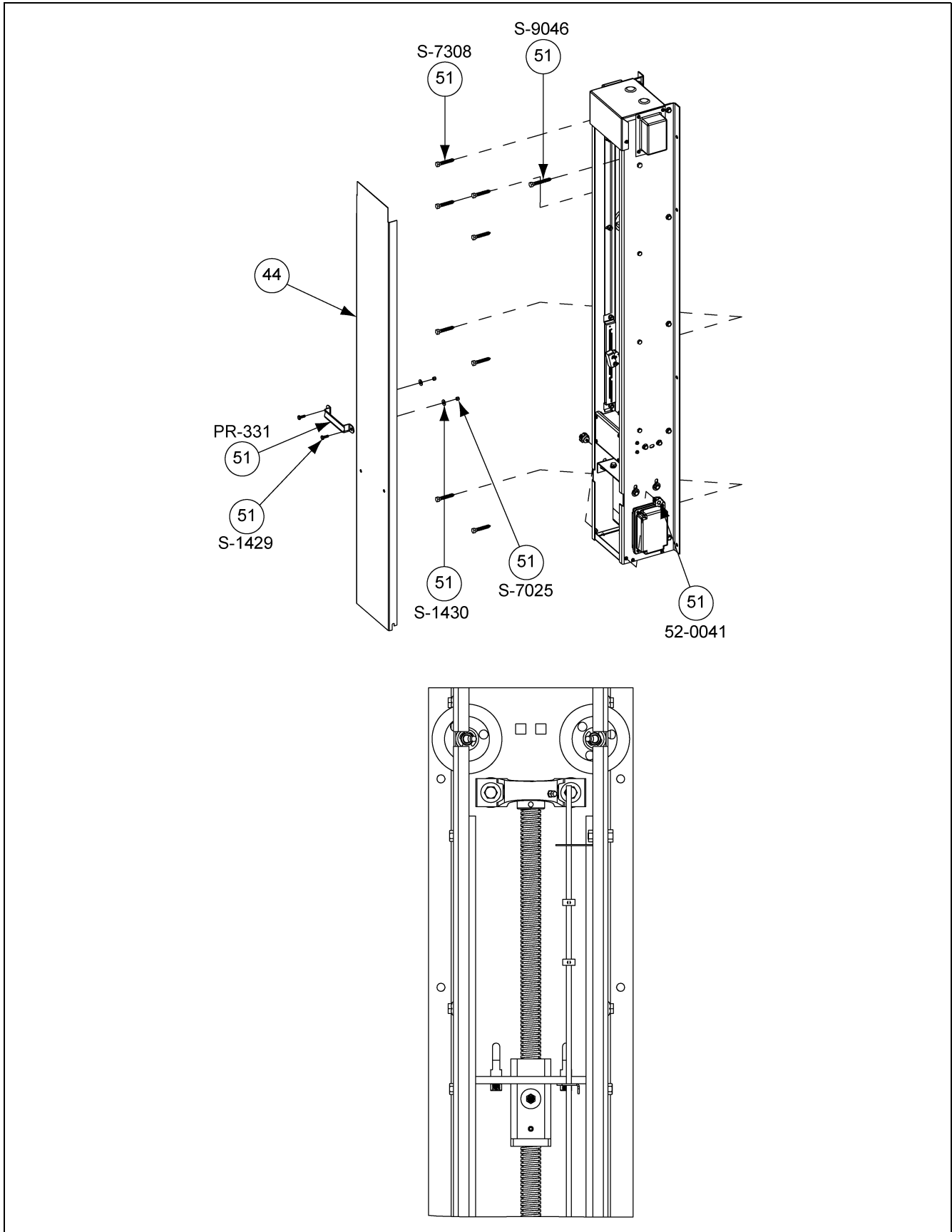

## Motor Components Parts List

Ref #	Part #	Description	Qty
1	52-0004	Base Plate 3'	1
2	52-0001	Frame Side Left 3'	1
3	52-0002	Frame Side Right 3'	1
4	52-0006	Pulley Support Plate	1
5	52-0188M	Sprocket/Pulley Shoulder Bolt	2
6	52-0010	Pulley Spacer	2
7	50-0089	Pulley w/ Needle Bearing	2
8	S-8072	Bolt, HHCS 5/16"-18 x 3/4" ZN	9
9	S-1147	Split Lock Washer 5/16" ZN	12
10	S-396	Nut 5/16"-18	15
11	52-0007	Angle (Drive Block) 3	2
12	50-0043	Nutsert 3/8"-16 ALS7-616-150	2
13	S-8739	Flat Washer 3/8" x 1-1/2" x 1/4" TH	2
14	52-0348	Bearing, 1" Pillow Block with Set Screws	1
15	50-0056	Drive Screw, 36" Travel	1
16	52-0330	Coupler, Drive One Piece Machined	1
17	52-0012	Coupler, Spider Hytrel 7/8" F/LO95 Love Joy	1
18	52-0051	Motor Assembly, 30 RPM CC	1
19	52-0172	Limit Switch Assembly 3'	1
20	52-0276	Drive Block Assembly w/ Nylon Insert	1
21	AC52-0174	Bearing Kit w/ Bearing Cover Nut	1
22	52-0195	4" x 6" Electrical Box Assembly CC MAC	1
23	52-0021	Top Cover	1
24	52-0044	Caplug, BPF-1	2
25	53-0007	Pulley Cover	2
26	52-0022	End Cap	1
27	S-280	Screw, SDS #10-16 x 5/8" HWH ZN	18
28	S-7927	Flange Bolt 3/8"-16 x 1" ZN Grade 8	18
29	S-248	Flat Washer 3/8" 7/16" I.D. x 1" O.D. YDP	10
30	S-1146	Bolt, HHCS 5/16"-18 x 1" ZN Grade 2	3
31	52-0036	Latch Out Switch Bracket	1
32	S-1054	Lock Washer, 3/8"	14
33	S-456	Hex Nut 3/8"-16 YDP Grade 5	14
34	S-8979	Nutsert 1/4"-20 Yellow Dichromate	2
35	S-8798	Screw, SDS #10-16 x 5/8" HWH ZN	4
36	S-2086	Bolt, HHCS 3/8"-16 x 1-1/2" ZN Grade 8	2
37	FH-1310	Cord Connector, Heyco	2
38	FH-1309	Lock Nut 1/2" #401 ARL.	2
39	1573	Regular Limit Switch	1
40	1568	Whisker Switch/Limit Switch	1
41	S-7148	Weld Nut 6-32 Tap 1" Centers	1
42	S-8780	Screw, MS #6-32 x 2-1/2"	2
43	S-8940	Wing Nut #6-32 ZN Grade 2	2
44	52-0025	Front Cover 3' AVS Curtain Control	1
45	DC-889	Decal, Danger High Voltage	1
46	DC-1516	Decal, Caution Automatic Equipment	1
47	DC-818	Decal, New CC Front Panel	1
48	DC-1345	Decal, Danger Sprocket/Chain	1
49	DC-1538	Decal, CC-Grease Zerk Locations	1
50	DC-789	Decal, Orange Adjustment Line	2
51	52-0211	CC Hardware Package	1
52	S-9319	Clevis Pin 1/4" x 2"	1
53	S-6626	Cotter Pin 3/32" x 1/2" ZN Grade 2	1
N/S	7098659	Trim Sof-Tone Red Double Lip 1/16"	1

## AC180-A Installation Kit (Purchased Separately)

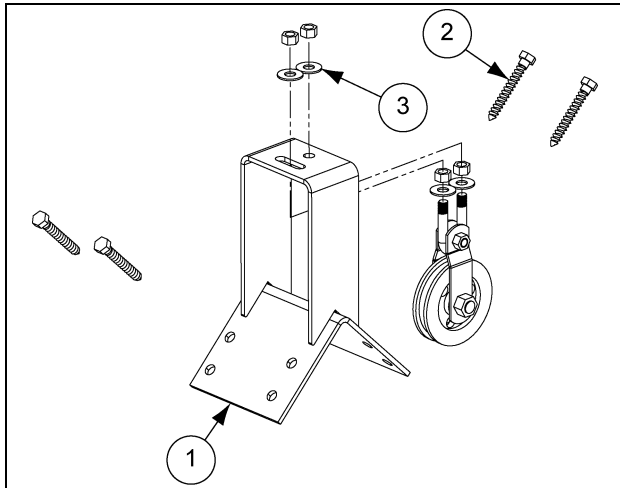

Figure 9A AC1820 Assembly

AC1820 Bracket - Outside Corner Assembly			
Ref #	Part #	Description	Qty
1	BAC1820	Corner Bracket Assembly	1
2	S-9046	Screw, Lag 3/8" x 3" HH ZN Grade 2	4
3	S-248	Flat Washer 3/8" 7/16" I.D. x 1" O.D. YDP	4
4	S-6554	Tie, Wire 8" Plastic	1

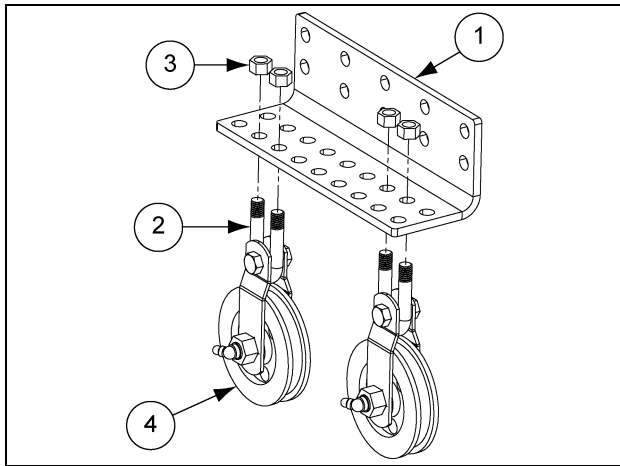

Figure 9B AC1821 Assembly

AC1821 Bracket - 3" x 3" x 9" 2 Pulleys Assembly			
Ref #	Part #	Description	Qty
1	1821	Bracket - 3" x 3" x 9" for 2 Pulleys	1
2	S-9206	Bolt, U-Bolt 3/8"-16 x 2" Long x 1"	2
3	S-456	Hex Nut 3/8"-16 YDP Grade 5	4
4	1902AA	Pulley, 3-1/2" O.D. Cast Iron WI	2

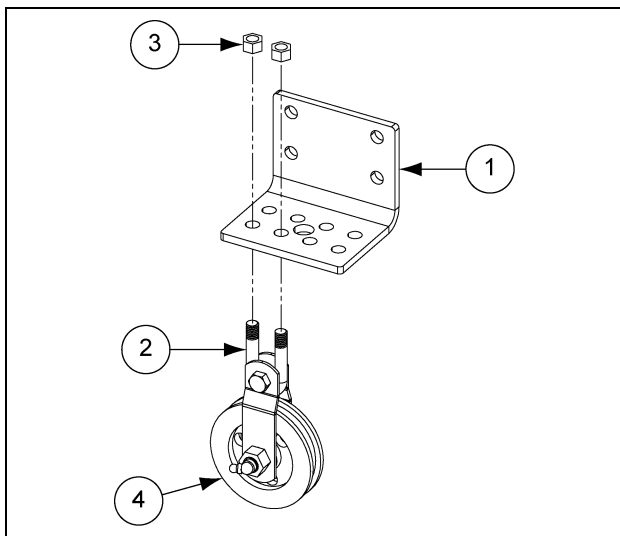
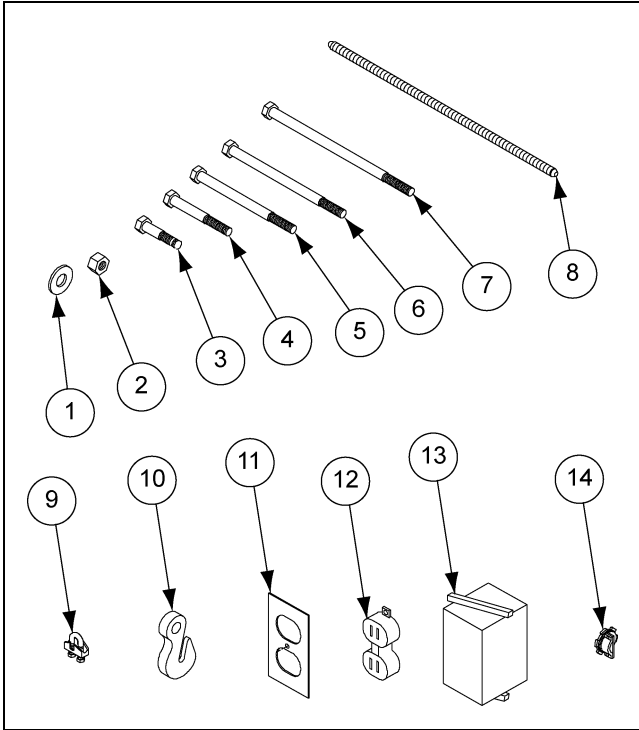

Figure 9C AC1822 Assembly

AC1822 Bracket - 3" x 3" x 3" 1 Pulley Assembly			
Ref #	Part #	Description	Qty
1	1822	Bracket - 3" x 3" x 3" for 1 Pulley	1
2	S-9206	Bolt, U-Bolt 3/8"-16 x 2" Long x 1"	1
3	S-456	Hex Nut 3/8"-16 YDP Grade 5	2
4	1902AA	Pulley, 3-1/2" O.D. Cast Iron WI	1

**AC180-A Installation Kit (Purchased Separately) (Continued)**



Ref #	Part #	Description	Qty
1	S-248	Flat Washer 3/8" 7/16" I.D. x 1" O.D. YDP	50
2	S-456	Hex Nut 3/8"-16 YDP Grade 5	20
3	S-7522	Bolt HHCS 3/8"-16 x 2" ZN Grade 2	5
4	S-7249	Bolt HHCS 3/8"-16 x 3" ZN Grade 5	6
5	S-7373	Bolt HHCS 3/8"-16 x 5" ZN Grade 2	2
6	S-7248	Bolt HHCS 3/8"-16 x 6" ZN Grade 2	2
7	S-8395	Bolt HHCS 3/8"-16 x 7" ZN Grade 2	4
8	8195	Rod Threaded 3/8"-16 x 12" Grade 2	4
9	S-8762	3/16" Cable Clamp, ZN Plated	11
10	1926	Hook Grab 1/4" Chain	2
11	1780	Handy Box Cover-Galvanized	1
12	1781	Duplex Receptacle-115V with Ground	1
13	1785	Handy Box-Surface Mount Nail On	1
14	1782	Connector, 3/8" Romex, 1/2" Thread	1

Figure 9D

NOTE: Assembly parts can be purchased separately.

**AC180-B Installation Kit (Purchased Separately)**

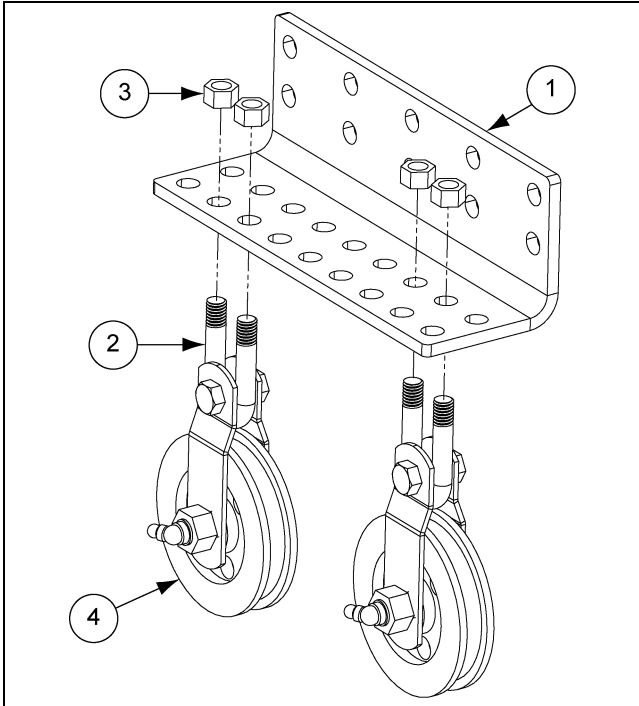

AC1821 Bracket - 3" x 3" x 9" 2 Pulleys Assembly			
Ref #	Part #	Description	Qty
1	1821	Bracket - 3" x 3" x 9" for 2 Pulleys	1
2	S-9206	Bolt, U-Bolt 3/8"-16 x 2" Long x 1"	2
3	S-456	Hex Nut 3/8"-16 YDP Grade 5	4
4	1902AA	Pulley, 3-1/2" O.D. Cast Iron WI	2

Figure 9E AC1821 Assembly

## 9. Installation Kit

### AC180-B Installation Kit (Purchased Separately) (Continued)

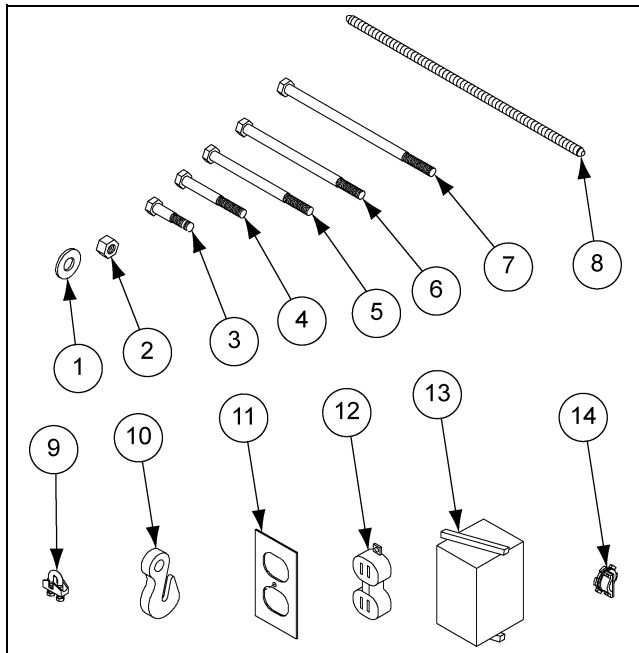

Ref #	Part #	Description	Qty
1	S-248	Flat Washer 3/8" 7/16" I.D. x 1" O.D. YDP	50
2	S-456	Hex Nut 3/8"-16 YDP Grade 5	21
3	S-7522	Bolt, HHCS 3/8"-16 x 2" ZN Grade 2	3
4	S-7249	Bolt, HHCS 3/8"-16 x 3" ZN Grade 5	3
5	S-7373	Bolt, HHCS 3/8"-16 x 5" ZN Grade 2	2
6	S-7248	Bolt, HHCS 3/8"-16 x 6" ZN Grade 2	2
7	S-8395	Bolt, HHCS 3/8"-16 x 7" ZN Grade 2	2
8	8195	Rod Threaded 3/8"-16 x 12" Grade 2	4
9	S-8762	3/16" Cable Clamp, ZN Plated	8
10	1926	Hook Grab 1/4" Chain	2
11	1780	Handy Box Cover-Galvanized	1
12	1781	Duplex Receptacle-115V with Ground	1
13	1785	Handy Box-Surface Mount Nail On	1
14	1782	Connector, 3/8" Romex, 1/2" Thread	1

Figure 9F

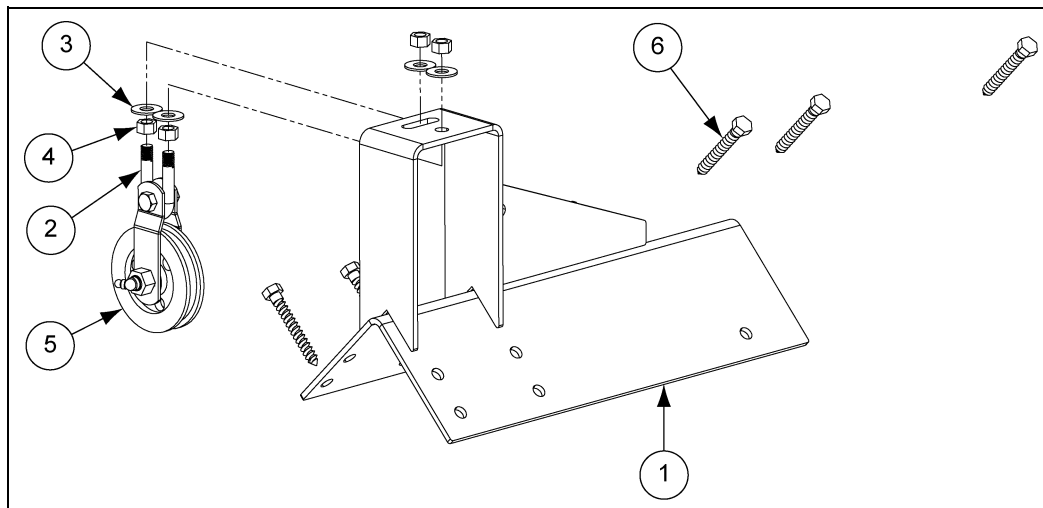

Figure 9G AC1820C Assembly

AC1820C Heavy Duty Outside Corner Bracket			
Ref #	Part #	Description	Qty
1	1820C1	Bracket - Outside Corner	1
2	S-9206	Bolt, U-Bolt 3/8"-16 x 2" Long x 1"	1
3	S-248	Flat Washer 3/8" 7/16" I.D. x 1" O.D. YDP	4
4	S-456	Hex Nut 3/8"-16 YDP Grade 5	4
5	1902AA	Pulley, 3-1/2" O.D. Cast Iron WI	1
6	S-9046	Screw, Lag 3/8" x 3" HH ZN Grade 2	6

**NOTE:** Assembly parts can be purchased separately.

## Outside Endwall Mount

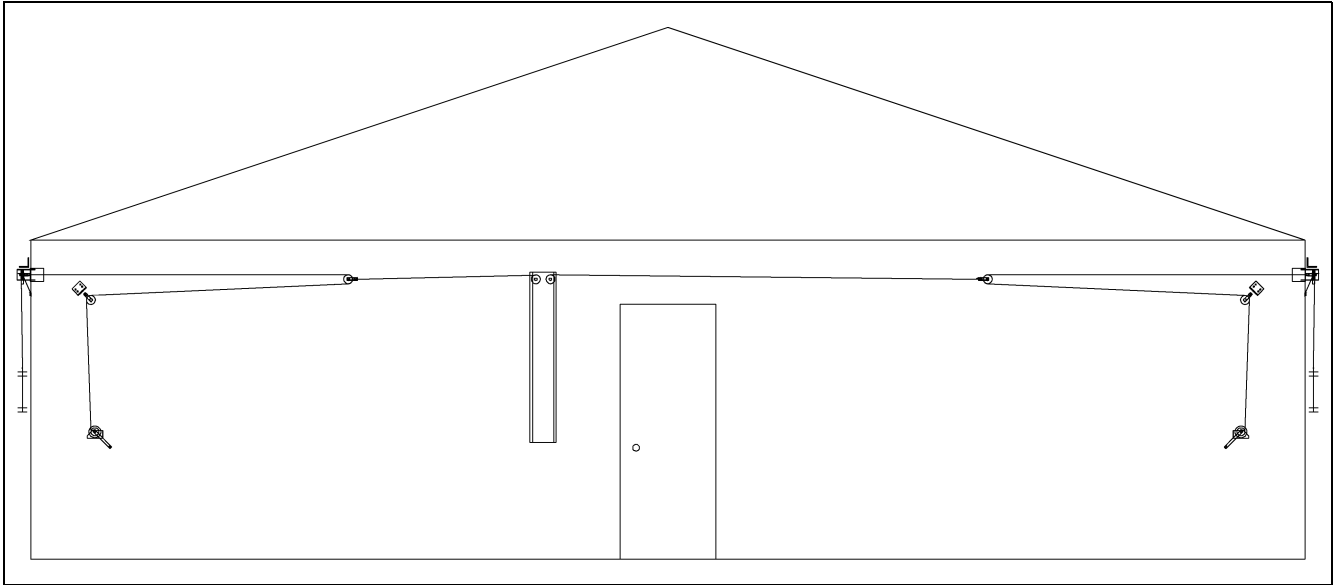

Figure 10A

The [Figure 10A](#) shows 1:2 cable configuration. This means: 1 foot (1') of cable movement at the machine equals 2 feet (2') of cable movement at the curtain.

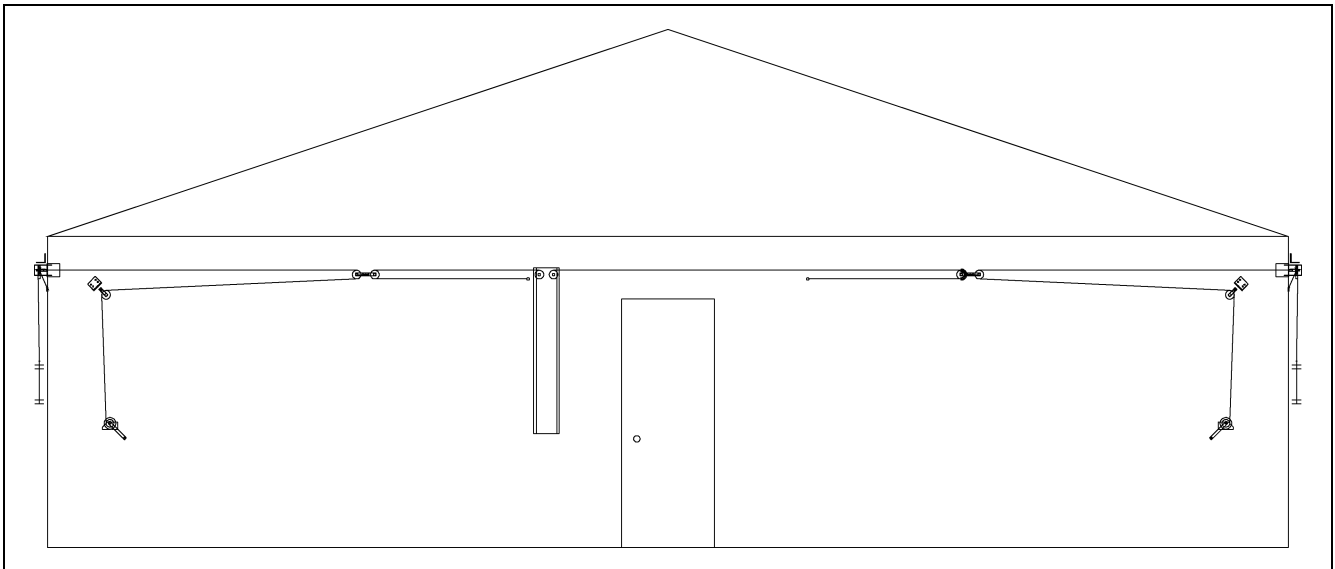

Figure 10B

The [Figure 10B](#) shows 1:1 cable configuration. This means: 1 foot (1') of cable movement at the machine equals 1 foot (1') of cable movement at the curtain.

## Outside Endwall Mount (Continued)

Illustration shows cable configuration of the sidewall.

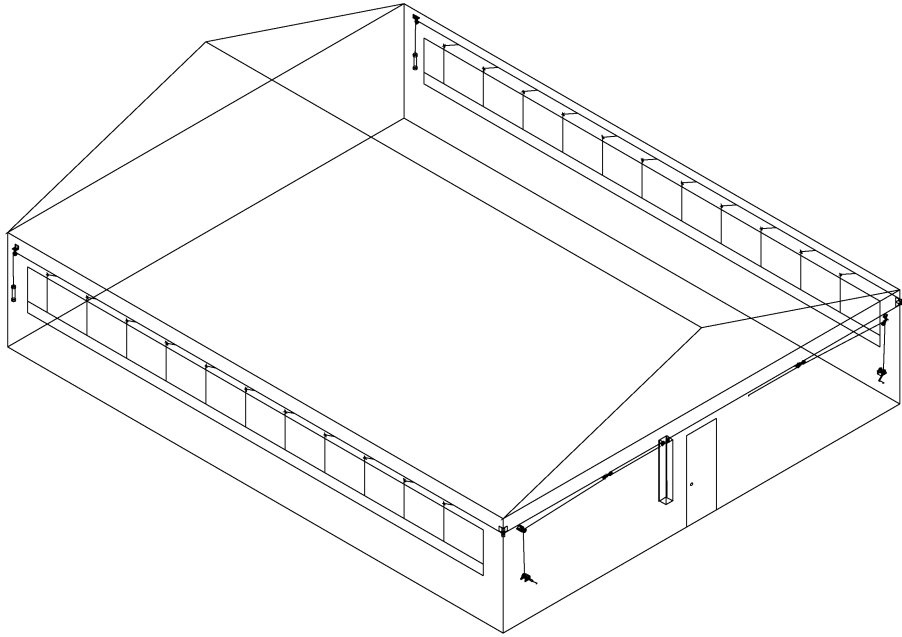

Figure 10C

The [Figure 10C](#) shows 1:1 cable configuration. This means: 1 foot (1') of cable movement at the machine equals 1 foot (1') of cable movement at the curtain.

## Outside Sidewall Mount

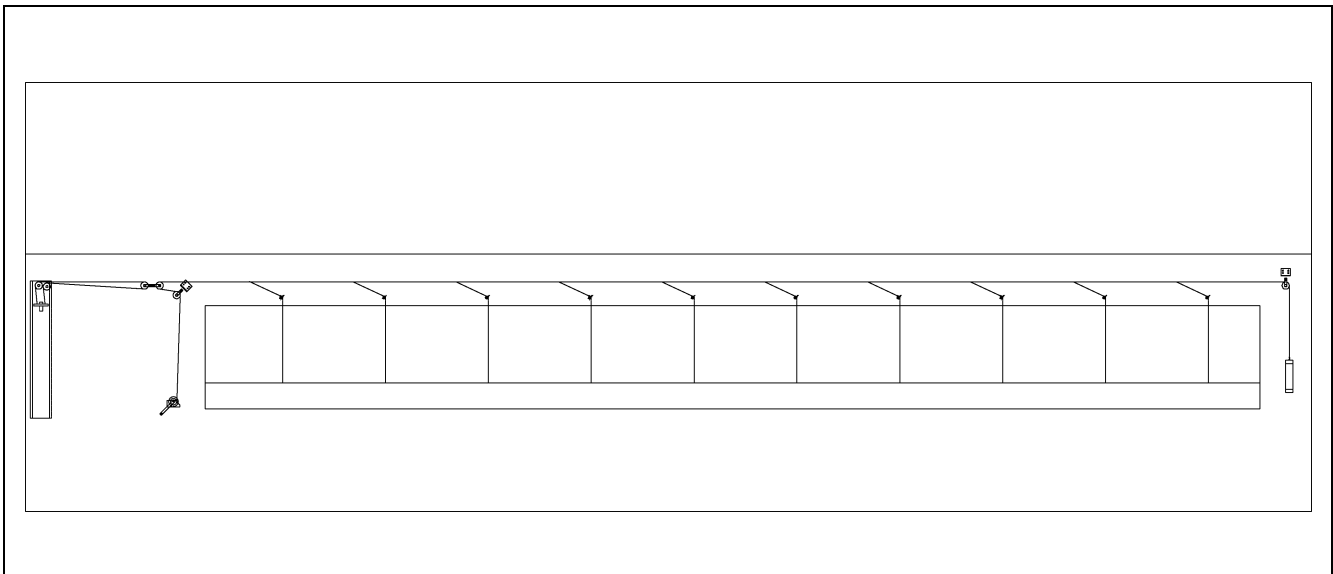
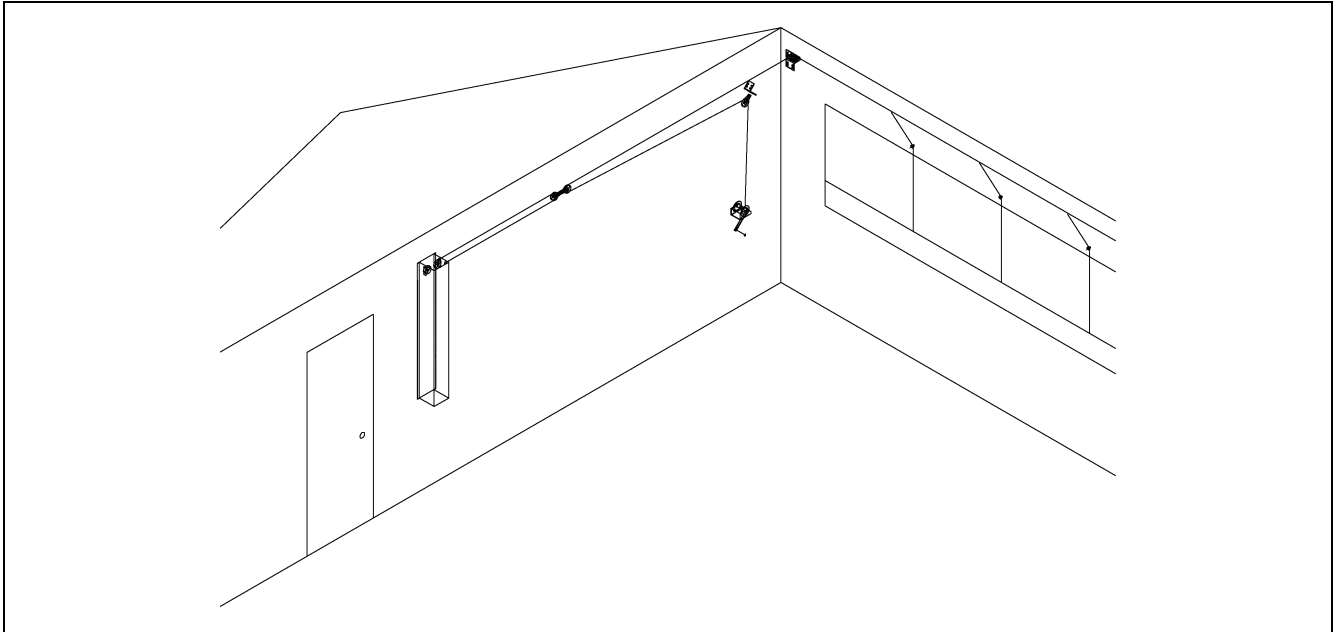

Figure 10D

The [Figure 10D](#) shows 1:2 cable configuration. This means: 1 foot (1') of cable movement at the machine equals 2 feet (2') of cable movement at the curtain.

## Inside Endwall Mount



**Figure 10E**

The [Figure 10E](#) shows 1:1 cable configuration. This means: 1 foot (1') of cable movement at the machine equals 1 foot (1') of cable movement at the curtain.

# Potentiometer Wiring Diagram

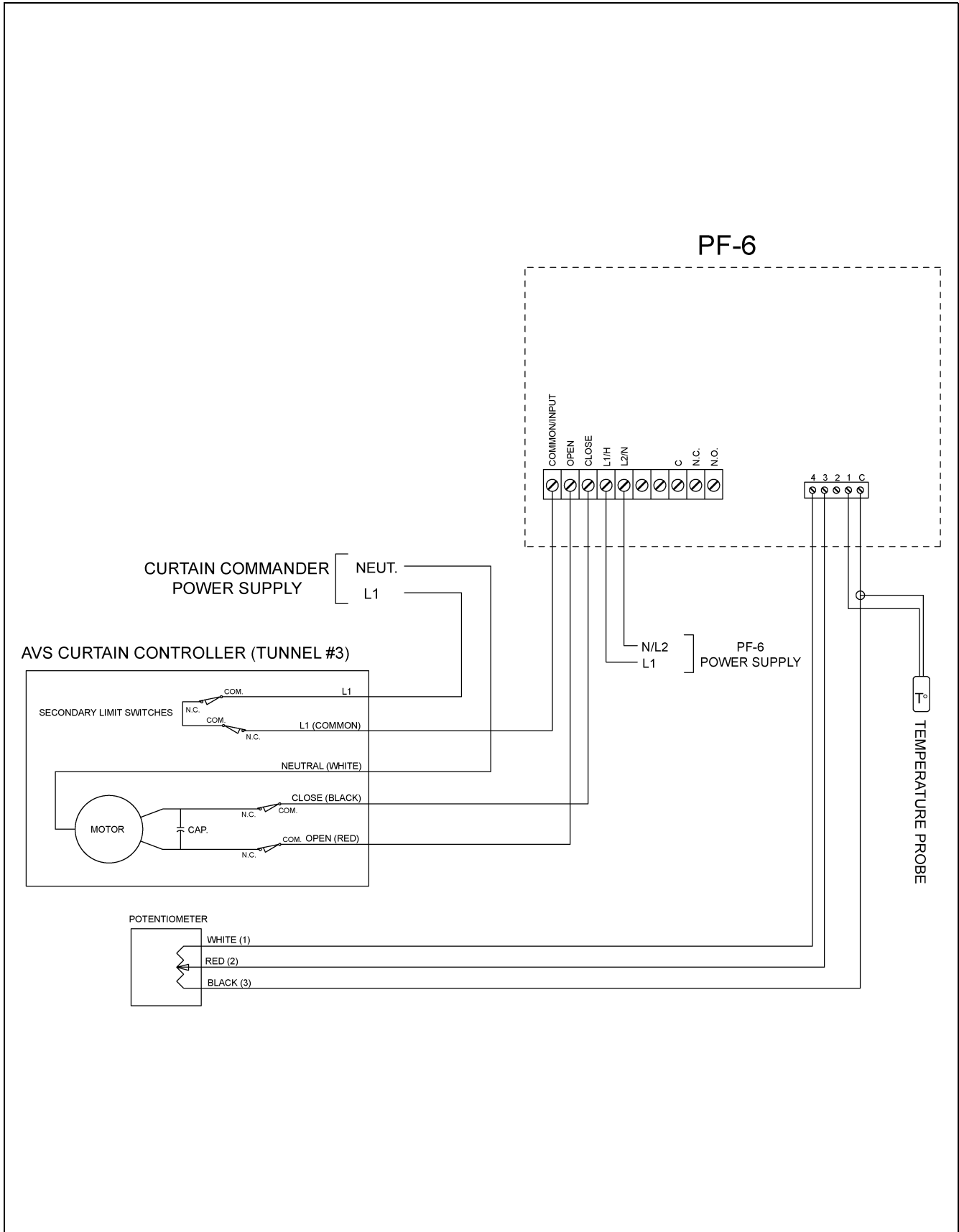

## Control Box Wiring

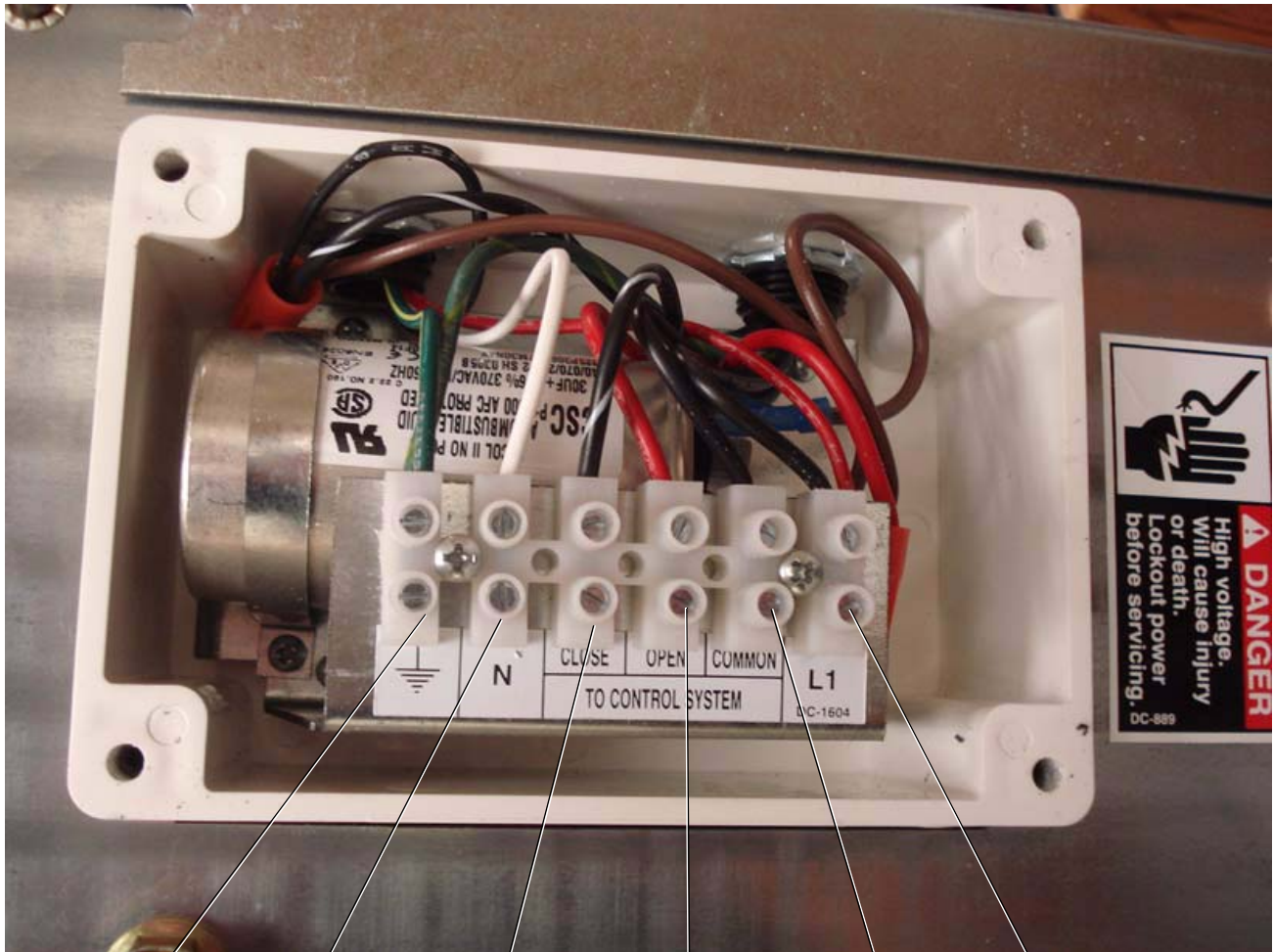

Ground

Neutral or L2

Close signal  
from controller

Open signal  
from controller

Common to  
controller

L1 Power

# 11. Wiring Diagrams

## Wiring Diagram for 110V 60 Hz

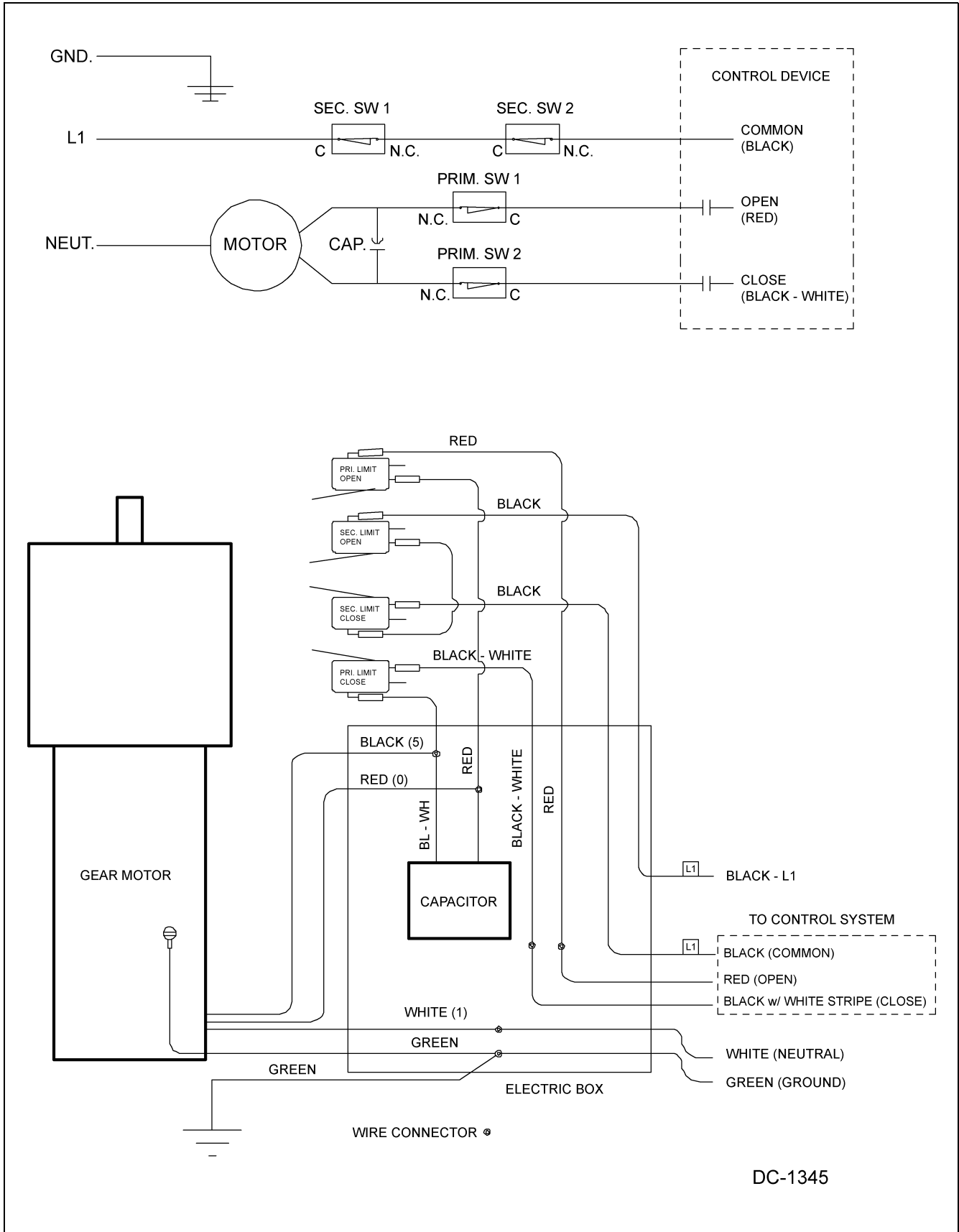

# Wiring Diagram for 220V 50/60 Hz

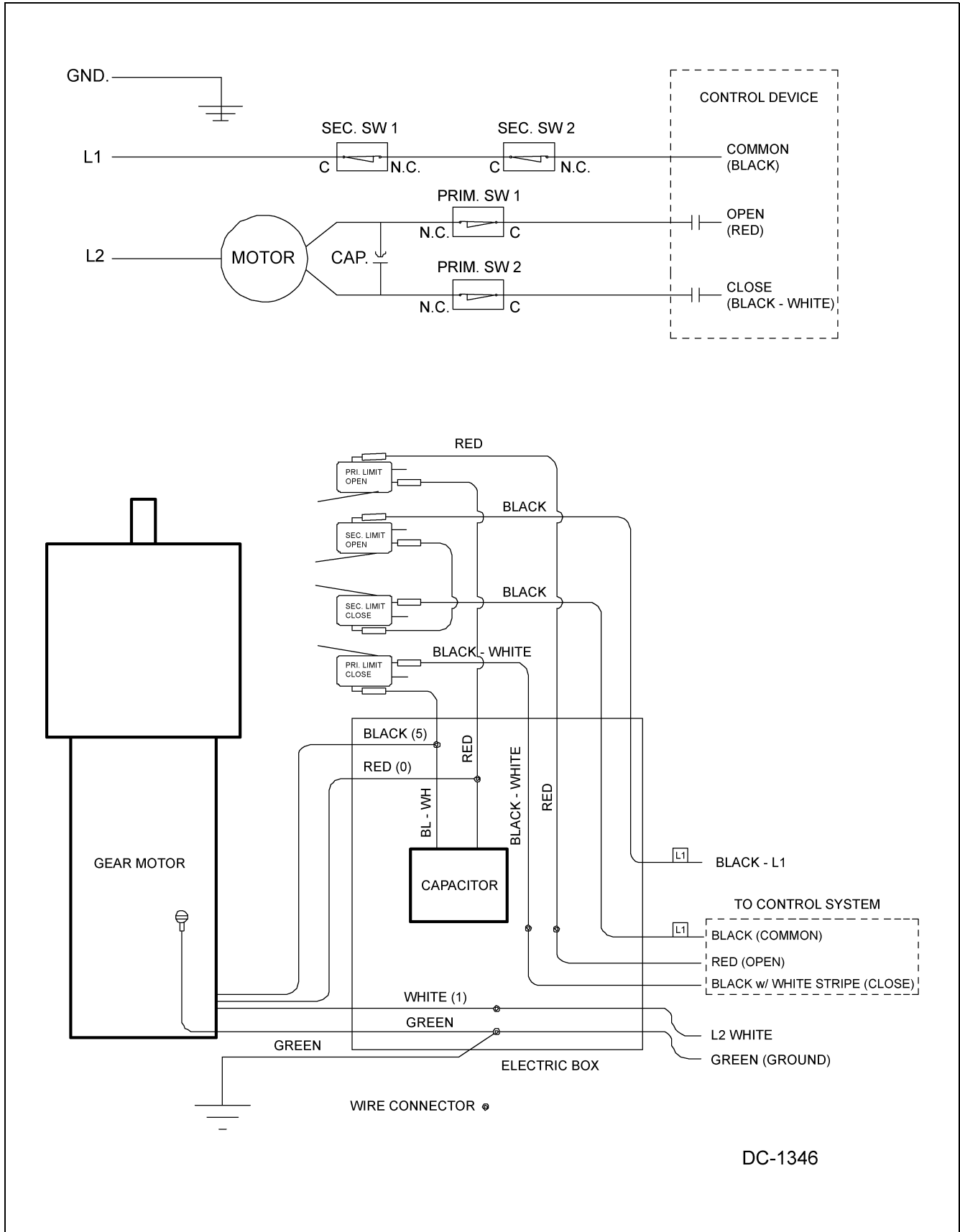

---

# NOTES

## GSI Group, LLC Limited Warranty

The GSI Group, LLC ("GSI") warrants products which it manufactures to be free of defects in materials and workmanship under normal usage and conditions for a period of 12 months after sale to the original end-user or if a foreign sale, 14 months from arrival at port of discharge, whichever is earlier. The end-user's sole remedy (and GSI's only obligation) is to repair or replace, at GSI's option and expense, products that in GSI's judgment, contain a material defect in materials or workmanship. Expenses incurred by or on behalf of the end-user without prior written authorization from the GSI Warranty Group shall be the sole responsibility of the end-user.

### Warranty Extensions:

The Limited Warranty period is extended for the following products:

	Product	Warranty Period
<b>AP Fans and Flooring</b>	Performer Series Direct Drive Fan Motor	3 Years
	All Fiberglass Housings	Lifetime
	All Fiberglass Propellers	Lifetime
<b>Cumberland Feeding/Watering Systems</b>	Feeder System Pan Assemblies	5 Years **
	Feed Tubes (1-3/4" and 2.00")	10 Years *
	Centerless Augers	10 Years *
	Watering Nipples	10 Years *
<b>Grain Systems</b>	Grain Bin Structural Design	5 Years
<b>Grain Systems Farm Fans Zimmerman</b>	Portable and Tower Dryers	2 Years
	Portable and Tower Dryer Frames and Internal Infrastructure †	5 Years

\* Warranty prorated from list price:  
 0 to 3 years - no cost to end-user  
 3 to 5 years - end-user pays 25%  
 5 to 7 years - end-user pays 50%  
 7 to 10 years - end-user pays 75%

\*\* Warranty prorated from list price:  
 0 to 3 years - no cost to end-user  
 3 to 5 years - end-user pays 50%

† Motors, burner components and moving parts not included. Portable dryer screens included. Tower dryer screens not included.

GSI further warrants that the portable and tower dryer frame and basket, excluding all auger and auger drive components, shall be free from defects in materials for a period of time beginning on the twelfth (12<sup>th</sup>) month from the date of purchase and continuing until the sixtieth (60<sup>th</sup>) month from the date of purchase (extended warranty period). During the extended warranty period, GSI will replace the frame or basket components that prove to be defective under normal conditions of use without charge, excluding the labor, transportation, and/or shipping costs incurred in the performance of this extended warranty.

### Conditions and Limitations:

THERE ARE NO WARRANTIES THAT EXTEND BEYOND THE LIMITED WARRANTY DESCRIPTION SET FORTH ABOVE. SPECIFICALLY, GSI MAKES NO FURTHER WARRANTY OF ANY KIND, EXPRESS OR IMPLIED, INCLUDING, WITHOUT LIMITATION, WARRANTIES OF MERCHANTABILITY OR FITNESS FOR A PARTICULAR PURPOSE OR USE IN CONNECTION WITH: (I) PRODUCT MANUFACTURED OR SOLD BY GSI OR (II) ANY ADVICE, INSTRUCTION, RECOMMENDATION OR SUGGESTION PROVIDED BY AN AGENT, REPRESENTATIVE OR EMPLOYEE OF GSI REGARDING OR RELATED TO THE CONFIGURATION, INSTALLATION, LAYOUT, SUITABILITY FOR A PARTICULAR PURPOSE, OR DESIGN OF SUCH PRODUCTS.

GSI shall not be liable for any direct, indirect, incidental or consequential damages, including, without limitation, loss of anticipated profits or benefits. The sole and exclusive remedy is set forth in the Limited Warranty, which shall not exceed the amount paid for the product purchased. This warranty is not transferable and applies only to the original end-user. GSI shall have no obligation or responsibility for any representations or warranties made by or on behalf of any dealer, agent or distributor.

GSI assumes no responsibility for claims resulting from construction defects or unauthorized modifications to products which it manufactured. Modifications to products not specifically delineated in the manual accompanying the equipment at initial sale will void the Limited Warranty.

This Limited Warranty shall not extend to products or parts which have been damaged by negligent use, misuse, alteration, accident or which have been improperly/inadequately maintained. This Limited Warranty extends solely to products manufactured by GSI.

Prior to installation, the end-user has the responsibility to comply with federal, state and local codes which apply to the location and installation of products manufactured or sold by GSI.

This equipment shall be installed in accordance with the current installation codes and applicable regulations which should be carefully followed in all cases. Authorities having jurisdiction should be consulted before installations are made.



1004 E. Illinois St.  
Assumption, IL 62510-0020  
Phone: 1-217-226-4421  
Fax: 1-217-226-4420  
[www.gsiag.com](http://www.gsiag.com)