

Mounting Instructions — Leave a clearance of at least 16" (400 mm) to the left of the controller box to allow the cover to be removed for maintenance.

Cable Entry — Punch holes at the bottom of the enclosure to allow wires to be introduced in the controller. Do not drill the top or side panels of the enclosure.

Alarm System — Installation of a good quality alarm system is strongly suggested to warn of power failures and high/low temperatures.

Surge Protection — Provide a surge protection (including lightning protection) from the power supply to the controller and from the control to the sensors. Consult a certified electrician if required.

3-Phase Power — Same phases must be used to power the variable fans and the controls on 3 phases power.

Low Voltage Wires — Install low voltage cables at least 12 inches (300 mm) away from high voltage cables (120, 230 or 380Vac or 24Vdc). Always use twisted shielded cables to wire low voltage devices and always cross high and low voltage cables at a 90° angle. This applies to :

- Sensor cables
- Potentiometer cables
- Communication cables
- Computer link cables
- 0-10V loads
- All other low voltage devices.

Water Meter — The water meter output should be a dry contact and should not pulse faster than 60 times a second (60Hz). A 22/12 AWG gauge cable no longer than 2000 feet (0.6 km) can be used to connect the water meter. Do not use a cable longer than 2000 feet even if a larger cable is used. **Do not run the meter cable outside the building!**

Relays — Dry Contact, 15 A RES, 50/60 Hz
16 FLA @ 120 Vac (1HP, 746 W)
12 FLA @ 240 Vac (2HP, 1490 W)
Max tungsten light: 8.3A @ 120Vac.

Load Supplies — 120-240 Vac, 50-60HZ 12-24 Vdc.

Backup Thermostats — The backup thermostats are shown for illustration purposes only. Sufficient backup thermostats must be used to ensure ventilation if the controller loses power.

Fuse Box — We recommend installing a fuse box on each stage.

Potentiometer's Color Legend

| Wire # | Commander Actuator | VonWeise Actuator |
|--------|--------------------|-------------------|
| 1 | White | Red |
| 2 | Red | Black |
| 3 | Black | White |

| WIRING DIAGRAM | |
|----------------|--------|
| EXPERT WW | |
| 891-00401 | Rev.04 |

Module & PC Line Connections

Set the end of line jumper to the "Yes" position on the first and last device of each communication line (MODULE & PC lines).

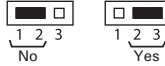

Connecting a Relay Panel (MODULE Line)

Relés 1-16, ID n°1

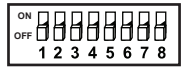

Relés 17-32, ID n°2

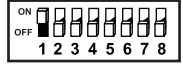

CS model >
(relay panel with 3 communication wires)

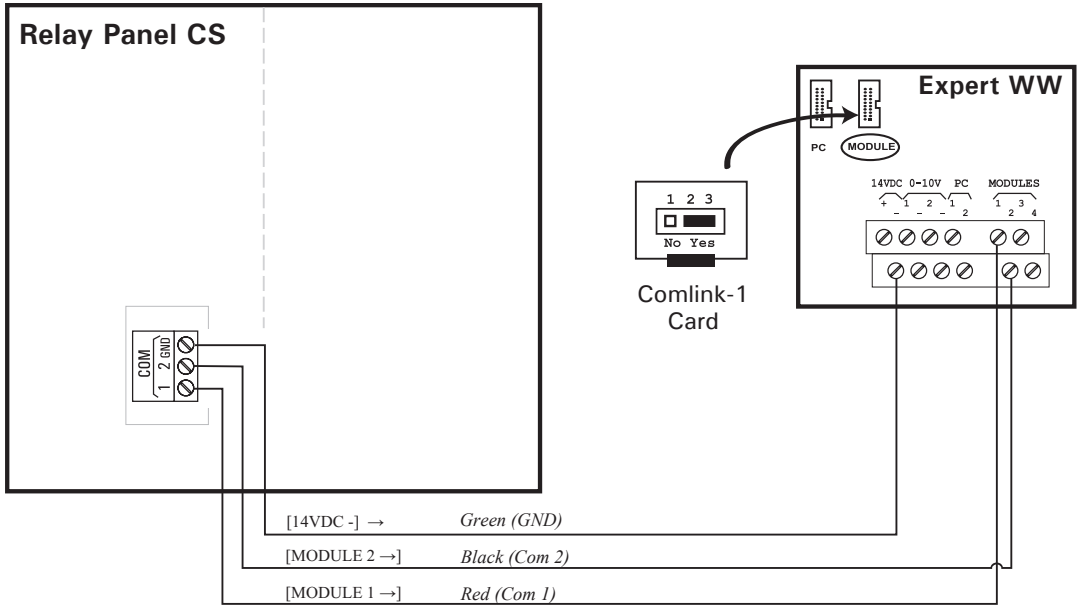

Non-CS model >
(relay panel with 4 communication wires)

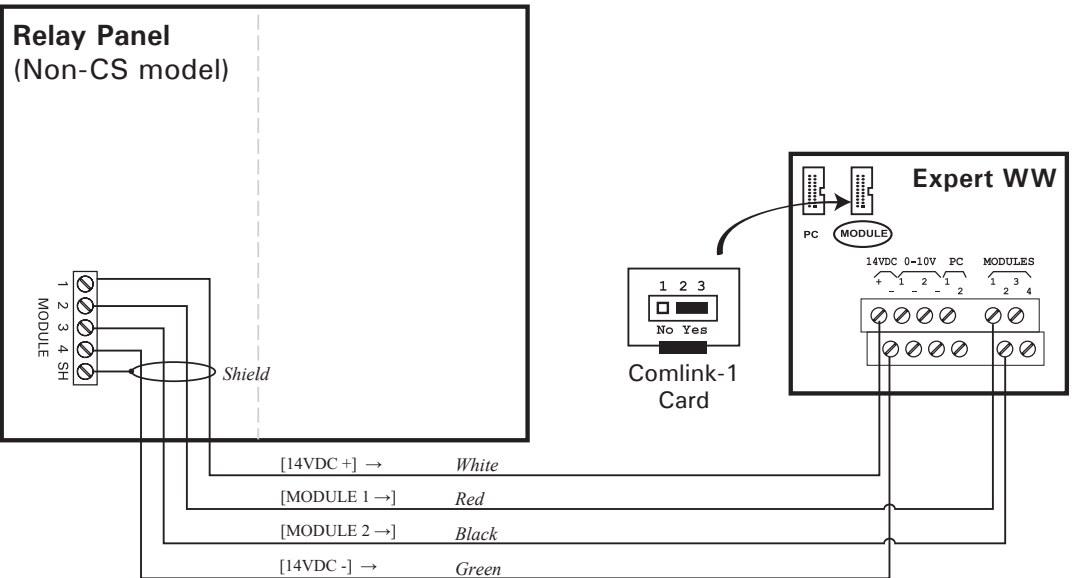

Connecting a Water Meter Module > (MODULE Line)

WME-8 Module ID # 3

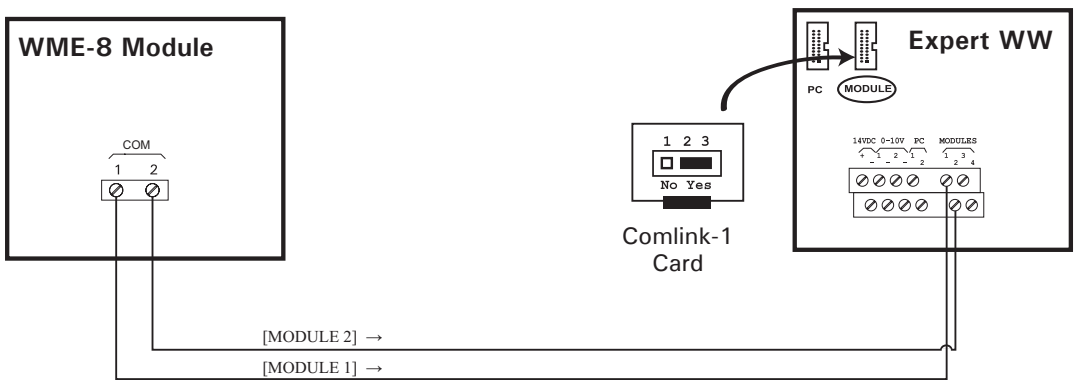
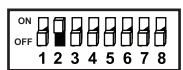

Connecting the ABOX > (PC Line)

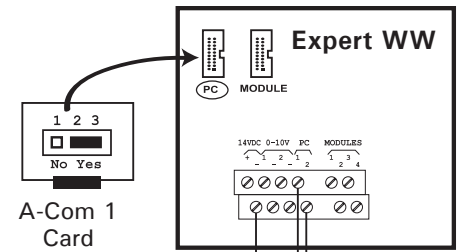
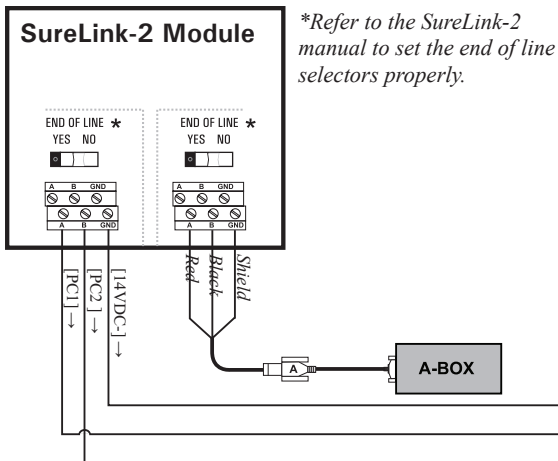

| WIRING DIAGRAM | |
|----------------|--------|
| EXPERT WW | |
| 891-00401 | Rev.04 |