

# EXPERT WW

## Temperature controller

### User's Manual

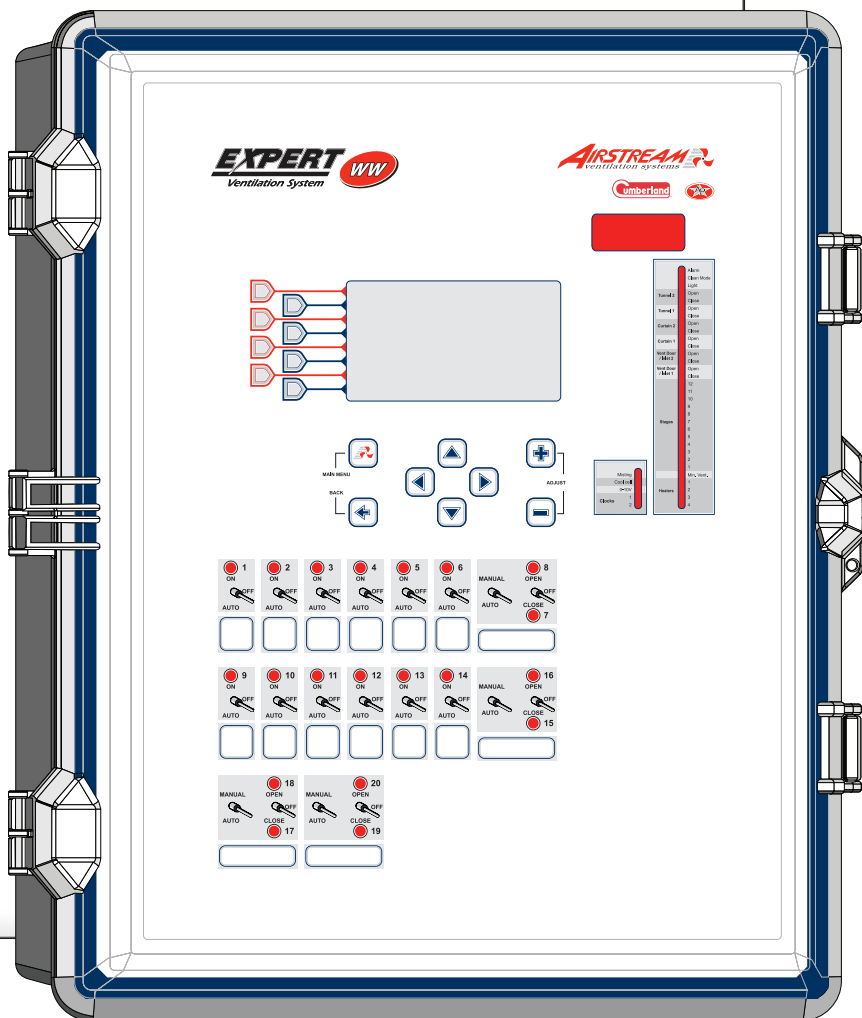

## **WARNINGS**

The warranty can be void if this product is used in a manner not specified by the manufacturer.

Every effort has been made to ensure that this manual is complete, accurate and up-to-date. The information contained in it is however subject to change without notice due to further developments.

## TABLE OF CONTENTS

<b>1. INTRODUCTION</b> .....	<b>5</b>	<b>6. VENTILATION &amp; COOLING</b> .....	<b>19</b>
1.1. Precautions .....	5	6.1. Minimum Ventilation .....	19
1.2. Symbols of the Manual .....	5	6.1.1. Minimum Ventilation Cycles .....	19
1.3. Controller's Overview .....	5	6.1.2. Minimum Vent. Settings.....	19
1.4. Main Features.....	6	6.1.3. Minimum Ventilation Curve.....	19
<b>2. MOUNTING INSTRUCTIONS</b> .....	<b>6</b>	6.2. Fan Stages .....	20
2.1. Installing the Controller on the Wall .....	6	6.2.1. Principle of Operation .....	20
2.2. Connections .....	6	6.2.1.1. Operation of Fan Stages.....	20
2.2.1. Main Wiring.....	6	6.2.2. Stage 1 Ramping.....	20
2.2.2. Alarm Connection .....	7	6.2.3. Fan Stage Settings .....	20
2.2.3. Sensor Inputs .....	7	6.2.4. 0-10V Ventilation Outputs .....	21
2.2.4. 0-10V Output Connection .....	7	6.3. Natural Ventilation Curtains .....	22
<b>3. USER INTERFACE</b> .....	<b>7</b>	6.3.1. Principle of Operation .....	22
3.1. Location of the Controls.....	7	6.3.2. Transition Between Natural & Tunnel Vent. .	23
3.2. Parameter Adjustment .....	8	6.3.3. Natural Ventilation Settings .....	23
3.3. Language Selection .....	8	6.3.4. Curtain Compensation.....	24
3.4. LED Meaning .....	8	6.3.5. Stopping the Fans in Natural Vent. ....	24
<b>4. INSTALLATION SETUP</b> .....	<b>9</b>	6.3.6. Purge.....	25
4.1. Setting the Time & Date .....	9	6.4. Tunnel Doors.....	25
4.2. Password .....	9	6.4.1. Pressure-based Tunnel Doors .....	25
4.2.1. Changing the Password .....	9	6.4.2. Temperature-Based Tunnel Doors .....	26
4.2.2. Retrieving a Lost Password.....	9	6.4.3. Tunnel Door Settings .....	27
4.3. Controller Programs.....	9	6.5. Vent Doors (Inlets) .....	28
4.3.1. Program Selection & Settings .....	9	6.5.1. Timer-based Vent Doors (Inlets) .....	28
4.3.2. Copying & Pasting Programs.....	10	6.5.1.1. Principle of Operation.....	28
4.4. Measuring Units.....	10	6.5.1.2. Vent Door Settings .....	28
4.5. Installation Setup .....	11	6.5.1.3. Actuator Reset.....	29
4.6. RH Compensation Setup .....	13	6.5.2. Potentiometer-based Vent Doors (Inlets).....	30
4.7. Probe Setup .....	13	6.5.2.1. Principle of Operation.....	30
4.7.1. Probe Activation .....	13	6.5.2.2. Vent Door Settings .....	30
4.7.2. Probe & Water Meter Calibration .....	13	6.5.2.3. Vent Door Calibration.....	31
4.7.3. Probe Assignment .....	14	6.5.3. Static Pressure-Based Vent Doors (Inlets) ....	31
4.8. Relay Assignment .....	14	6.5.3.1. Principle of Operation.....	31
4.8.1. Assigning Relays to the Outputs .....	14	6.5.3.2. Vent Door Settings .....	32
4.8.2. Assigning Min. Vent. Relays .....	15	6.6. 0-10V Air Inlet.....	32
4.9. Night Settings.....	15	6.7. Cool Cell.....	33
4.10. Clean Mode.....	15	6.8. Misting Output.....	33
4.11. Test Mode.....	16	<b>7. HEATING</b> .....	<b>34</b>
4.12. Version .....	16	<b>8. LIGHTS</b> .....	<b>35</b>
<b>5. TEMPERATURE &amp; SET POINT SETTINGS</b> .....	<b>17</b>	<b>9. CLOCK OUTPUTS</b> .....	<b>36</b>
5.1. Temperature Set Point .....	17	<b>10. RELATIVE HUMIDITY (RH) COMPENSATION</b> .....	<b>37</b>
5.2. Static Pressure Set Points .....	17	<b>11. ALARMS</b> .....	<b>38</b>
5.3. Temperature Curve.....	18	11.1. Alarm Log .....	38
5.3.1. Principle of Operation .....	18	11.2. Alarm Conditions .....	38
5.3.2. Settings .....	18	11.3. Alarm Settings.....	39
5.3.3. Modifying Curve Points.....	18		

<b>12.</b>	<b>MONITORING FUNCTIONS .....</b>	<b>40</b>
12.1.	Current Conditions .....	40
12.2.	Run Time Histories .....	40
12.3.	History Menus .....	40
12.4.	Animal Age & Count.....	41
12.5.	Automatic Reminder .....	41
<b>13.</b>	<b>TECHNICAL SPECIFICATIONS .....</b>	<b>42</b>
<b>14.</b>	<b>MEMORY CARD .....</b>	<b>43</b>
14.1.	Principle of Operation .....	43
14.2.	Accessing the Transfer Menu .....	43
14.3.	Configuration Transfer .....	43
14.3.1.	Installing a New Configuration .....	43
14.3.2.	Saving a Configuration on the Card .....	43
14.4.	Firmware Update.....	44
14.5.	Erasing the Memory Card .....	44
<b>15.</b>	<b>INDEX .....</b>	<b>45</b>

## 1. INTRODUCTION

### 1.1. Precautions

 **WARNING: Read and save these instructions!**

Safety may be jeopardized if the equipment is used in a manner not specified by the manufacturer. Carefully read and keep the following instructions for future reference.

We strongly recommend installing supplementary natural ventilation as well as a backup thermostat on at least one cooling stage.

Although fuses at the input and outputs of the controller protect its circuits in case of an overload or over-voltage, we recommend installing an additional protection device on the controller's supply circuit.

The room temperature where the controller is located must always remain between 32°F and 104°F (0°C to 40°C). Indoor use only!

To avoid exposing the controller to harmful gases or excessive humidity, it is preferable to install it in a corridor.

If the equipment is used in a manner not specified by the manufacturer, the protection provided by the equipment may be impaired.

Do not spray water on the controller! In order to clean the control, wipe it with a damp cloth.

 **Before servicing or cleaning unit, switch power off at service panel and lock the switch disconnecting means to prevent power from being switched accidentally. When the service disconnecting means cannot be locked, securely fasten a prominent warning device, such as a tag, to the service panel.**

### 1.2. Symbols of the Manual



**Warning.** Read the following text carefully; it contains important information which, if ignored, may cause the controller to operate improperly.



**High Voltage. Hazard of electrical shock.** Read the message and follow the instructions carefully.



**Pay attention.** The following text contains very useful information.



**Press on the proper menu selector.**



**Press the "Main Menu" push-button.**



**Both direct and alternating current (AC/DC).**



**Direct current (DC).**



**Alternating current (AC).**



**Earth Ground Terminal**  
Primarily used for functional earth terminals which are generally associated with test and measurement circuits. These terminals are not for safety earthing purposes but provide an earth reference point.

**For Customer Use:** Enter below the serial number located on the side of the alarm system and keep this information for future reference.

Model:	EXPERT WW
Serial number:	_____
Date installed:	_____

### 1.3. Controller's Overview

The EXPERT WW is an electronic device used for environmental control in livestock buildings. It combines sidewall and tunnel ventilation into one powerful system.

20 built-in relays &  
32 optional relays to control:

- 4 heating stages;
- 12 fan stages;
- 2 tunnel doors;
- 2 natural ventilation curtains;
- 2 vent doors (inlets);
- 2 clock outputs;
- 1 misting output;
- 1 cool cell output;
- 4 feeders;
- 1 backup relay;

1 built-in 0-10V output to control an inlet or variable-speed fans;

1 built-in 0-10V output to control lighting equipment.

#### INPUTS:

- 8 inside temperature sensors;
- 2 outside temperature sensors;
- 1 inside humidity sensor;
- 1 outside humidity sensor;
- 1 static pressure probe;
- 9 water meters.

 **Refer to the end of this manual to connect the sensors and loads.**

## 1.4. Main Features

### Very Large LCD Display

A large LCD screen provides an efficient interface for displaying, monitoring and adjusting the parameters.

### 3 Controller Programs

The controller allows using 3 different programs to control the room temperature. It is thus possible to activate a specific program, that uses particular temperature settings, in accordance with the animal age for instance.

### Status LEDs

Pilot lights that indicate the status of the controller outputs are located on the faceplate of the controller. These LEDs allow monitoring the system's operation without having to enter the building.

### Minimum Ventilation Cycle

When ventilation is not required to reduce the room temperature, fan outputs can run either continuously or intermittently to reduce humidity levels and supply oxygen to the room.

### 8 Indoor Temperature Sensors

Up to eight temperature sensors can be connected to the controller to obtain an accurate reading of the average room temperature and a faster reaction time.

### Natural Ventilation Curtains

The controller can open 2 natural ventilation curtains and stop all ventilation when the outside temperature is sufficiently warm.

### Tunnel Ventilation

When the room temperature rises, tunnel ventilation reduces the actual temperature perceived by the animals.

### Humidity Control

The inside and outside relative humidity sensors allow controlling humidity levels in the room.

### 0-10V Output

The controller has 2 internal 0-10V outputs. The first 0-10V output can either be used to control an air inlet or variable-speed fans and the second output can control lighting equipment.

### Control Of The Air Inlet Movement

The movement of vent doors (inlets) can be coordinated with the operation of the fans using a potentiometer located on the panel drive or a timer. This allows the vent doors (inlets) to be adjusted correctly, without the influence of uncontrollable factors such as wind or air from adjoining rooms

### History Menus

History menus allow monitoring the sensor readings and verify the run time of some outputs. The controller comes with the following histories menus:

- Minimum & maximum sensor readings:
  - Ambient temperature..... 60 days
  - Inside temperature sensors ..... 10 days
  - Outside temperature sensor ..... 75 days
  - Inside humidity sensor..... 75 days
  - Outside humidity sensor ..... 75 days
  - Static pressure sensor ..... 75 days
- Run time of each heater ..... 75 days
- Run time of each feeder..... 75 days
- Daily water consumption ..... 75 days

### Alarm Management

The controller provides alarms for high-low temperatures, defective sensors and other system failures. It keeps in memory the 20 most recent alarm conditions.

### Password Protection

A password can be enabled to restrict access to the setup functions of the controller.

### Backup Battery

A backup battery allows the unit to keep time in case of a power failure.

### Overload And Overvoltage Protection

Resettable fuses are provided at low-voltage inputs of the controller to protect its circuitry in the case of an overload or overvoltage.

### Computer Control

The controller can be connected to a computer, thus making it possible to centralize the management of information and diversify control strategies.

### Test Mode

A test mode allows you to simulate temperature changes and verify controller performances.

## 2. MOUNTING INSTRUCTIONS

### 2.1. Installing the Controller on the Wall

Fasten the two metal brackets on the mounting holes located behind the controller using six screws. Then, mount the enclosure on the wall using four other screws. Leave a clearance of at least 16" to the left of the enclosure to allow the cover to be removed for maintenance.

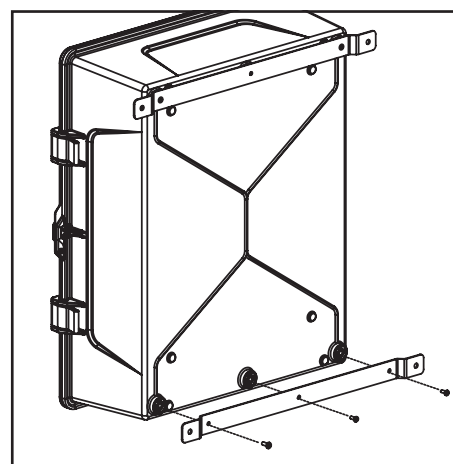

### 2.2. Connections

#### 2.2.1. Main Wiring

Refer to the wiring diagram enclosed with this user's manual to connect the controller. Drill holes at the bottom of the enclosure to pass the wires and install watertight connectors to prevent water from entering in the enclosure. Do not make any holes at the side and top of the enclosure.



**All wiring must be done by an authorized electrician and must comply with applicable codes, laws and regulations. Make sure power is off before doing any wiring to avoid electrical shocks and equipment damage.**





### 3.2. Parameter Adjustment

Use the navigation buttons to select the desired parameter on the main screen. A parameter that can be modified blinks when it is selected; non-blinking parameters cannot be changed.

### 3.3. Language Selection

The user interface of the controller can be displayed in multiple languages. Follow these steps to change the language selection:

1. Select:

-  Main menu
-  More [Otros]
-  Español [English]

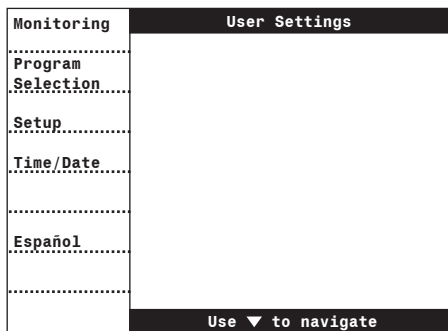

2. The controller automatically changes the language display.

 **Press and hold the main menu button for 5 seconds to switch the language selection.**



### 3.4. LED Meaning

LED		MEANING
ALARM	Solid LED:	"An alarm condition is active. A corrective action is required."
	Flashing LED:	"An alarm condition occurred but no longer exists. "
CLEAN MODE	Solid LED:	Clean mode is active.
LIGHTS	Solid LED:	Lights are ON.
TUNNEL 2	Open	Solid LED: tunnel door #2 is opening.
	Close	Solid LED: tunnel door #2 is closing.
TUNNEL 1	Open	Solid LED: tunnel door #1 is opening.
	Close	Solid LED: tunnel door #1 is closing.
CURTAIN 2	Open	Solid LED: natural ventilation curtain #2 is opening.
	Close	Solid LED: natural ventilation curtain #2 is closing.
CURTAIN 1	Open	Solid LED: natural ventilation curtain #1 is opening.
	Close	Solid LED: natural ventilation curtain #1 is closing.
VENT DOOR / INLET 2	Open	Solid LED: vent door (inlet) #2 is opening.
		Flashing LED: the controller opens vent door (inlet) #2 to reset the actuator's position.
	Close	Solid LED: vent door (inlet) #2 is closing
		Flashing LED: the controller closes vent door (inlet) #2 to reset the actuator's position.
VENT DOOR / INLET 1	Open	Solid LED: vent door (inlet) #1 is opening.
		Flashing LED: the controller opens vent door (inlet) #1 to reset the actuator's position.
	Close	Solid LED: vent door (inlet) #1 is closing
		Flashing LED: the controller closes vent door (inlet) #1 to reset the actuator's position.
STAGES 1-12	Solid LED:	fan stage #x is active.
MINIMUM VENTILATION	Solid LED:	On Time of the minimum ventilation timer.
	Flashing LED:	Off Time of the minimum ventilation timer.
HEATERS 1-4	Solid LED:	Heating output #x is active (if Hi Fire option is not used) or the Hi and Lo fire steps are ON.
	Flashing LED:	the Hi or Lo fire heating step is on
MISTING	Solid LED:	the misting output is active.
COOL CELL	Solid LED:	the cool cell output is active.
O-10V OUTPUT	Solid LED:	O-10V output #1 is active.
CLOCK 1-2	Solid LED:	clock output #x is active.

## 4. INSTALLATION SETUP

### 4.1. Setting the Time & Date

1. Select:

-  Main menu
-  Time / Date

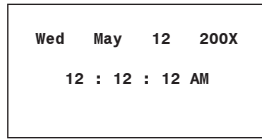

2. Press the right-arrow key once. The current month flashes on the display.
3. Use the adjustment buttons to adjust the month.
4. Press the right-arrow key to step to the next parameter.
5. Proceed in similar fashion to set the whole time and date.

### 4.2. Password

The controller can use 3 password levels:

#### User 1 password [1-1-1-1]

This password provides access to temperature set points, minimum ventilation settings and to the animal count menu.

#### User 2 [2-2-2-2]

This password provides access to all menus except for installation setup menus. This password can be modified as explained below.

#### Installer password [0-6-1-0]



This password provides access to all functions of the controller. It can be modified as explained below.

 **Choose an easy-to-remember password and write it down in a safe place!**

Using passwords is optional. Refer to the Installation Setup section of this manual to enable or disable passwords and to choose the default password level (section 4.5). The default user level is selected after 15 minutes of inactivity.

#### 4.2.1. Changing the Password

1. Select:

-  Main menu
-  Setup \*
-  User
-  Password

\* A password may be required to access this menu.

Password	
Current mode	Installer
Change User	0 * * *
Change Password	* * * *





2. Use the adjustment buttons to set the first number of the password then press the right-arrow key. Proceed the same way to enter all numbers of the password then press the right-arrow key. The user is then identified.

3. If the installation password or user 2 password is posted, the prompt "Change Password" appears on screen. Use the adjustment buttons to set the new password code.

4. Use the adjustment buttons to confirm the new installer password then press the right-arrow key to confirm the new password.

#### 4.2.2. Retrieving a Lost Password

1. Select:

-  Main menu
-  Setup \*
-  User
-  Password
-  User Password\*\*

\* If the controller prompts for a password, enter the factory password (contact your dealer).

\*\*This menu is accessible from the factory level only.

User	Password
User 1:	1111
User 2:	2222
Installer:	0000

2. The password of all user levels are displayed on screen.

### 4.3. Controller Programs

#### Program definition:

Programs are an assembly of settings (temperature settings, relay assignment, probe assignment, etc.) that can be enabled at different moment of the breeding process. In all, the controller can use 3 different programs.

#### Automatic program selection:

The controller can automatically switch the program selection when the animals reach a certain age and/or as a function of outside temperature. Refer to the Installation Setup section of this manual to enable or disable the automatic program switch (see section 4.5).

 **Refer to the Installation Setup section of this manual to set the number of programs in use and to enable or disable the automatic program switch (section 4.5).**

#### 4.3.1. Program Selection & Settings

The controller can automatically switch the program selection when the animals reach a certain age and/or as a function of outside temperature. If the automatic program switch option is enabled in the Installation setup (sec. 4.5), you must indicate the moment at which each program starts.

 **Make sure the right program is selected before adjusting any parameter.**

1. Select:

-  Main menu
-  Setup \*
-  Program

\* A password may be required to access this menu.

Program Settings	
Program 2 above day:	10
Program 3 above day:	20
Program 2 above Out T:	50.0
Program 3 above Out T:	75.0
Show Settings :	Program 1
[ or ]	
Running Prog.:	Program 1
Use ▼ to navigate	

2. Set the following parameters:

**Program #x above** — If the program switch is based on the animal age, select the day at which programs 2 and 3 start; if the switch is based on the outside temperature, select the outside temperature above which each program starts. Note that program 1 is automatically used when the animal age (or outside temperature) is lower than the value defined for programs 2 and 3.

**Show settings of** — Even when a program is running you can still display parameter settings of other programs without changing the program in use. Select the desired program to be displayed on screen. *\*Only the programs that are enabled in the Installation Setup are available (see sec. 4.5).*

**Running program** — This message is shown when the program selection is made manually (i.e., it is not selected as a function of the day and/or outside temperature). Select the running program. *\*Only programs that are enabled in the Installation Setup are available (see sec. 4.5).*

 *The day number refers to the animal age.*

## 4.3.2. Copying & Pasting Programs

Use the copy-paste function to duplicate all parameter settings associated to a program onto another program. This avoids repeating the same programming sequence several times.

1. Select:

-  Main menu
-  Setup \*
-  Copy/Paste

*\* A password may be required to access this menu.*

Program Settings	
Copy From:	Program 1
Copy to:	Program 2
Confirm?	No

2. Set the following parameters:





**Copy From** — Select the source program. The one that will be duplicated.

**Copy to** — Select the target program. The one on which the copied program will be pasted.

3. Once a different source and target programs are selected, the message "Confirm?" is displayed. Select "Yes" to start the program duplication. The message "Copy in progress" is displayed. Wait until the data transfer is over.

## 4.4. Measuring Units

1. Select:

-  Main menu
-  Setup \*
-  User
-  Units

*\* A password may be required to access this menu.*

Unit Selection	
Time Display	AM/PM
Temperature	Deg F
Water	Liter
Static Pressure	"WC

2. Select the proper measuring units:

**Time display** — AM/PM / 24 hours;

**Temperature units** — Celsius (Deg C) or Fahrenheit (Deg F).

**Water** — Gallons / Liters

**Static Pressure** — Inches of water ("WC) or Pascal (Pa).

 *Measuring units are common to all programs of the controller.*

## 4.5. Installation Setup

The following section shows how to customize the controller for your particular application. It shows how to enable and set the outputs of your controller. Normally, this setup needs to be done only once.

The following parameters must be set separately for each controller program in use.

1. Select:

-  Main menu
-  Setup \*
-  User
-  Install

\* A password may be required to access this menu.

Installation	
# Feeders	4
# Heater stages	4
Use Heater Lo/Hi Fire?	Yes
# Fan stages	8
# Clocks	2
# Natural Curtain	2
# Tunnel Curtain	2
# Light Programs	3
# Vent Doors/Inlets	2
Vent Door/Inlet 1 Mode	Time
Vent Door/Inlet 2 Mode	S.P.
#Static.P Set Points	3
Tunnel Curtains Mode	SP
Tunnel Follows Natural	Yes
Close Vents in Natural	No
Use 0-10V Output	Yes
0-10V Type	0-10V
0-10V Mode	Ventil.
0-10V Follow SetP	Yes
0-10V For Min Vent ?	No

Use ▼ to navigate

 **Hint:** use the right and left arrow keys to move up and down through the display by pages.

2. Set the following parameters:

**Number of feeders** — The controller has 4 inputs that are used to monitor the run time of feeder motors. Enable the proper number of feeder inputs (0 to 4 feeders).

**Number of heating stages** — Enable the proper number of heating stages — (0 to 4 heating stages).

**Use Heater Lo/Hi Fire?** — Select “Yes” to activate the heating outputs’ Lo & Hi fire option. This function allows doubling the number of

heating stages. *\*[This parameter is common to all programs].*

**Number of fan stages** — Enable the proper number of fan stages (0 to 12 fan stages).

**Number of clock outputs** — Enable the proper number of clock outputs (0 to 2 clock outputs).

**Number of natural ventilation curtains** — Enable the proper number of natural ventilation curtains (0 to 2 natural ventilation curtains).

**Number of tunnel curtains** — Enable the proper number of tunnel curtains (0 to 2 tunnel curtains).

**Number of light programs** — Enable the proper number of light programs (0 to 10 light programs). Note that lighting programs are based on the animal age. Consequently, enabling a light program automatically enables age-based functions.

**Number of vent doors / inlets** — Enable the proper number of vent door (inlet) outputs (0 to 2 outputs).

**Vent door/inlet 1-2 mode** — Vent doors (inlets) can operate 3 different ways (see below): *\*This parameter is accessible if a vent door (inlet) output is enabled above. [This parameter is common to all programs].*

**1. Time** — The vent door (inlet) opens or closes in timer mode, as a function of temperature.

**2. Potentiometer (Pot.)** — The vent door (inlet) reaches predefined positions with the help of a potentiometer, as a function of temperature. Only the first vent door (inlet) output can use a potentiometer.

**3. Static pressure (S.P.)** — The vent door (inlet) opens or closes as a function of static pressure.

**Number of static pressure set points** — The controller can use up to 3 groups of static pressure set points and each group starts at a user-defined fan stage. *\*This parameter is accessible if at least one air inlet output (inlet, vent door or tunnel curtain) operates according to the static pressure level.*

**Tunnel Curtain’s Mode** — Does the tunnel door opens and closes according to the static pressure level (S.P.) or according to the room temperature. *\*This parameter is accessible if the tunnel curtain is activated above. The static pressure option is only available if the static pressure sensor is activated in section 4.7.1.*

**Tunnel follows Natural** — Select “Yes” to use tunnel doors in natural ventilation. When they are used in natural ventilation, tunnel doors follow the same progression as natural ventilation curtains (tunnel door 1 follows curtain 1, tunnel door 2 follows curtain 2); select “No” to disable this function.

**Close vents in natural** — Select “Yes” for vent doors (inlets) to close when the controller enters in natural ventilation. *\*This parameter is accessible if natural ventilation curtains and vent doors/inlets are enabled.*

**0-10V output** — Select “Yes” to enable the 0-10V output. This output can either be used to control an air inlet or a variable fan stage.

**0-10V Type** — Select the type of signal used by the 0-10V output (0-10V or 10-0V). *\*Accessible the 0-10V output is enabled above. [This parameter is common to all programs].*

**0-10V mode** — Select the function of the 0-10V output: *\*This parameter is accessible if the 0-10V output is enabled above. [This parameter is common to all programs].*

**1. 0-10V ventilation output** — When it is used for ventilation, the 0-10V output runs similarly as a variable-speed fan stage and uses independent temperature settings.

**2. 0-10V inlet** — When it is used as an air inlet, the 0-10V output opens and closes an actuator as a function of the ventilation level.

**0-10V output follows set point** — Operating temperatures of the 0-10V output can either be related to the set point – which means the controller automatically adjusts them when the set point changes – or they can be set as absolute values. Select “Yes” if they follow the set point or select “No” if they set as absolute values. *\*This parameter is accessible if a 0-10V ventilation output is enabled above and it is common to all programs.*

Installation		
0-10V For Min Vent ?	No	
Use Curtain 1 Compens?	Yes	
Use Curtain 1 Whisker?	Yes	
Use Curtain 2 Compens?	Yes	
Use Curtain 2 Whisker?	Yes	
Use Ramping in Stage1?	Yes	
Use Purge?	Yes	
Use Misting?	Yes	
Mist Follow Set Point?	Yes	
Use Cool Cell?	Yes	
Use Backup Relay	Yes	
Use RP-16	No	
Use RP-32	Yes	
Use Age?	Yes	
Use Temperature Curves?	Yes	
Number of Programs	3	
Switch Program by Age	Yes	
Switch Program by OutT	Yes	
Use Password?	Yes	
Use Password Level	User 1	
Clear Alarm Log?	No	
Digit Display	T°	

Use ▼ to navigate

**0-10V For Min Vent ?** — Select “Yes” to use the 0-10V fan output in minimum ventilation or select “No” to disable this function. Refer to section 6.2.4 for further information on this type of output. *\*This parameter is accessible if a 0-10V ventilation output is enabled above and it is common to all programs.*

**Curtain compensation** — Select “Yes” to enable a compensation on the opening of natural ventilation curtains as a function of the outside temperature. *\*This parameter is accessible if natural ventilation curtains are enabled above and if an outside temperature sensor is enabled in section 4.7.1.*

**Whisker switch** — Whisker switches tell the controller when natural ventilation curtains are sufficiently opened. Select “Yes” to enable the whisker switch input of each curtain or select “No” if these switches are not used. *\*[This parameter is common to all programs].*

**Ramping in stage 1** — Select “Yes” to activate the ramping function on stage 1 fans. This function allows smoothing out transition between minimum ventilation cycles and stage 1.

**Purge** — The purge function allows opening natural ventilation curtains on a short period of time to purge the air continuously. Select “Yes” to enable this function.

**Misting** — The controller can control one misting output. Select “Yes” to enable this output.

**Misting output follows the set point** — Operating temperatures of the misting output can either be related to the set point – which means the controller automatically adjusts them when the set point changes – or they can be set as absolute values. Select “Yes” if they follow the set point or select “No” if they set as absolute values. *\*This parameter is accessible if the misting output is enabled above. [This parameter is common to all programs].*

**Cool cells** — The controller can control one cool cell output. Select “Yes” to enable this output.

**Backup relay** — The controller can control one backup relay. Select “Yes” to use a backup relay. *\*[This parameter is common to all programs].*

**Use RP-16 / Use RP-32** — It is possible to connect one (1) external relay panel to the controller. If required, enable the proper type of panel: RP-16 or RP-32. *\*[This parameter is common to all programs].*

**Use age-based functions ?** — Some functions of the controller are based on the age of the animals (temperature curve, controller programs and lighting programs). Select “Yes” to use age-based functions or select “No” to disable them. *\*[This parameter is common to all programs].*

**Temperature curve** — The temperature curve is used to change the temperature set point over time. Select “Yes” to use this curve. *\*This parameter is accessible if age-based functions are enabled above. [This parameter is common to all programs].*

**Number of programs** — The controller can use several temperature programs. Enable the desired number of programs (1 to 3 programs) *\*[This parameter is common to all programs].*

**Switch program by Age / Out T° ?** — The controller can automatically enable a new program when the animals reach a certain age and/or as a function of outside temperature. Specify what factor causes a change in the program selection: “Age” and/or “ Out T” . Answer “No” to both questions if you do not want the controller to change the program automatically. *\*[These parameters are common to all programs].*

**Use password?** — Select “Yes” to enable the password protection or “No” to disable it. *\*[This parameter is common to all programs].*

**Use password level** — Select the default user level used by the controller (user 1, user 2 or installer). *\*This parameter is accessible if the password protection is enabled above. [This parameter is common to all programs].*

**Clear alarms?** — Select “Yes” to reset the alarm log. *\*This parameter is common to all programs].*

**Digit display** — Select what piece of information must be shown on the red LED display:

T° : temperature;

SP : static pressure;





T°/SP : temperature alternating with the static pressure;

*\*[This parameter is common to all programs].*

## 4.6. RH Compensation Setup

The controller offers different ways to compensate for high and low relative humidity (RH) levels in the barn. This section shows how to enable the desired RH compensation functions.

1. Select:

-  Main menu
-  Setup \*
-  User
-  RH Compens\*\*

\* A password may be required to access this menu.

\*\* This menu is accessible if a humidity sensor is enabled (sec. 4.7.1).

RH Compensation		
.....	RH Compens Heaters?	Yes
.....	Use Mist Shutoff?	Yes
.....	Use Mist on Lo %RH	Yes
.....	Use Cool Cell Shutoff	Yes

2. Enable or disable the following relative humidity (RH) compensation options:

 *The following parameters are common to all programs of the controller.*

**RH compensation with heaters** — The controller can compensate for high humidity levels by activating heating outputs in timer mode. Select “Yes” to use this compensation method.

**Mist Shutoff** — The controller can deactivate the misting output when humidity levels are too high. Select “Yes” to use this compensation method.

**Misting on low humidity levels (% RH)** — The controller can activate misting outputs when humidity levels are too low. Select “Yes” to use this compensation method.



**Cool cell shutoff** — The controller can deactivate the cool cell output when humidity levels are too high. Select “Yes” to use this compensation method.

## 4.7. Probe Setup

### 4.7.1. Probe Activation

Follow these steps to enable or disable the probe inputs.

1. Select:

-  Main menu
-  Setup \*
-  User
-  Probes

\* A password may be required to access this menu.

Probe Selection		
.....	Number of Inside Probe	4
.....	Use Inside RH Probe?	Yes
.....	Use Outside RH Probe?	Yes
.....	# Water Meter	8
.....	# Outside T° Probe	2
.....	Use SP Probe?	Yes

2. Enable or disable the following probe inputs:

 *The following parameters are common to all programs of the controller.*

**Inside probe** — Select the number of inside temperature probes that are connected to the controller (1 to 8 probes).

**Inside relative humidity (RH) probe** — Select “Yes” if an indoor humidity probe is connected to the controller.

**Outside relative humidity (RH) probe** — Select “Yes” if an outdoor humidity probe is connected to the controller.

**Water meter** — Enable the desired number of water meter inputs (1 to 9). Note that the controller only has 1 built-in water meter input. Connect water meters 2-9 to an external water meter module.

**Outside T°** — Select the number of outside temperature probes that are connected to the controller (0 to 2 probes).

**Static pressure (SP) probe** — Select “Yes” if a static pressure sensor is connected to the controller.

### 4.7.2. Probe & Water Meter Calibration

You can slightly adjust the reading of each probe input in order to obtain accurate and uniform readings from all probes. In addition, if a water meter is used, you must calibrate its water flow rate.

1. Select:

-  Main menu
-  Setup \*
-  User
-  Prb Calib

\* A password may be required to access this menu.

Probe Calibration		
.....	Temperature Probe 1	0.0 °F
.....	Temperature Probe 2	0.0 °F
.....	Temperature Probe 3	0.0 °F
.....	Temperature Probe 4	0.0 °F
.....	Outside Probe 1	0.0 °F
.....	Outside Probe 2	0.0 °F
.....	Inside Humidity	0%
.....	Outside Humidity	0%
.....	Static Pressure	.000 "WC
.....	Water 1 Calibration	1 g/p
.....	Water 2 Calibration	1 g/p
.....	Water 3 Calibration	1 g/p

Use ▼ to navigate

2. Adjust the reading of the probes (if required).

 *The following parameters are common to all programs of the controller.*

**Temperature probes (indoor & outdoor)** — The reading of inside and outside temperature probes can be adjusted of ±5°F (±2.8°C).

**Relative humidity probe** — The reading of inside and outside humidity probes can be adjusted of ±3%.

**Static pressure probe** — The reading of the static pressure probe can be adjusted of ±0.030"WC (±8Pa).

**Water meter calibration** — Specify the flow rate of each water meter. It can be adjusted from 1 to 100 gallons (or liters) per pulse.

## 4.7.3. Probe Assignment

This section explain how to select temperature probes that are used to measure the room temperature and how to assign temperature probes that are used to control/ monitor the outputs of the controller.

### Room Temperature Sensors:





Most cooling outputs of the controller (misting output, tunnel fans, stir fans, etc.) operate according to the average temperature in the room. The user must choose what temperature probes are used to measure this room temperature.

### Probe Set 2:

The selection of probes that is used to measure the room temperature can be changed in tunnel ventilation to compensate for changes in airflow patterns that can distort the room temperature calculation. If the second probe

set is enabled in the Installation Setup (sec. 4.5), you must assign temperature probes to this second probe set.

1. Select:

-  **Main menu**
-  **Setup \***
-  **Probe Assignment**
-  **Select the desired output\*\*:**
  - Room;
  - Probe Set 2;
  - Heaters 1-4 ;
  - Heaters 1-4 Hi fire (opt.) ;
  - 0-10V output;
  - Natural ventilation curtain 1-2;

\* A password may be required to access this menu.

\*\* Only outputs that are enabled in the Setup menu are displayed (sec. 4.5).

Heater 1 Probe Assignment					
.....	1 ---	2 ---	3 ---	4 ---	5 ---
.....	6 ---	7 ---	8 ---		

2. Assign the desired temperature probes to the selected output: select "✓" to assign a probe or select "- -" for probes that are not assigned to the output.





 **A template is available at the end of this manual to write down your selection of sensors.**

## 4.8. Relay Assignment

### 4.8.1. Assigning Relays to the Outputs

You must assign On/Off relays to each output of the controller. Use provided output stickers to identify the function of each relay on the faceplate of the controller.

1. Select:

-  **Main menu**
-  **Setup \***
-  **Relay**
-  **Select the desired output**

\* A password may be required to access this menu.

\*\*Only outputs that are enabled in the Setup menu are available (sec. 4.5).

Fan Stage 6 Relay Assignment					
.....	1 ---	2 ---	3 ---	4 ---	5 ---
.....	6 ✓	7 TMR	8 ---	9 ---	10 ---

2. Select a relay then set its status as follows:

- ✓ : The relay is assigned to the output;
- - - : The relay is not assigned to the output;
- TMR : The load connected to the relay will run in timer mode (available on fan stage outputs only).

 **Relays 21-52 correspond to the relays of an external relay panel (RP-16 or RP-32).**

3. Proceed in similar fashion to assign relays to each output in use:

**Fan stages 1-12** — Fan stages can either activate regular on/off relays and/or timer-based relays. When a timer-based relay is assigned to a fan stage, the relay runs in timer mode when the fan stage is active. This is useful to operate misting units for instance. To use timer-based relays, set the relay status to "TMR" (see example above). *\*Note that stage 1 cannot use timer-based relays.*

**Tunnel 1-2 / Vent door (inlet) 1-2 / Natural ventilation curtains 1-2** — Relays 7-8 and relays 15-20 have specially been designed for the connection of actuators. When actuators are connected to these relays, their open and close relays can never be activated at the same time.

**Feeding output** — Feeder relays are used to stop feeders when a feeder run time alarm occurs. These normally closed relays open when the alarm condition is detected. *\*This parameter is accessible if the feeder alarm condition is enabled (sec. 11.3).*

**Backup relay** — The backup relay box relay is a normally closed relay which opens in case of a power failure.

**Shutoff fans in natural ventilation** — It is possible to shutoff some fan output when the controller enters in natural ventilation (on/off fans and variable fans). Refer to the natural ventilation section of this manual to get further information about this feature.

**Heating stages 1-4 & Hi Fire 1-4 (opt.);**

**Misting output;**

**Cool cell output;**

**Clock outputs 1-2;**



**Light output.**

 **Worksheet showing default relay assignment and empty templates are available the end of this manual.**

## 4.8.2. Assigning Min. Vent. Relays

This procedure shows how to assign on/off relays to minimum ventilation cycles. Chosen relays will switch during the "On Time" portion of minimum ventilation cycles. Refer to section 6.1 for further information about minimum ventilation cycles.

1. Select:

-  Main menu
-  Min. Vent.
-  MinV Relays\*

\* A password may be required to access this menu.

Min Vent. Relay Assignment					
1	2	3	4	5	
---	---	---	---	---	
6	7	8	9	10	
---	---	---	---	---	
11	12	13	14	15	
---	---	---	---	---	
16	17	18	19	20	
---	---	---	---	---	
Use ▼ to navigate					

2. Set the status of each relay: select "✓" if the relay is used in minimum ventilation or select "-" if it is not.

 Relays 21-52 correspond to the relays of an external relay panel (RP-16 or RP-32).

## 4.9. Night Settings

Night functions allow changing the target room temperature and the minimum ventilation level when the night comes.

1. Select:

-  Main menu
-  Setup \*
-  User
-  Day/Night

\* A password may be required to access this menu.

Day Night Settings	
Night SetPoint?	Yes
Day Time	6:00A h:m
NightTime	6:00P h:m
Transition	60 min

2. Set the following parameters:

**Night Set Point?** — Select "Yes" to use a different target temperature at night; select "No" to disable this function.

**Day Time** — Set the time at which day settings start being used. \*This parameter is accessible if a night function is enabled above.

**Night Time** — Set the time at which night settings start being used. \*This parameter is accessible if a night function is enabled above.

**Transition** — If the night set point is enabled above, a transition is made from one set point to the other. Set this transition time to the desired value.

## 4.10. Clean Mode

The clean mode is used to interrupt regular operations of the controller when the room is empty. When this mode is enabled, the controller closes the tunnel door and the curtains. It also makes the vent doors (inlets) go to their "closed" position and then only provides a minimum level of heat and a minimum level of ventilation (optional). While the clean mode is enabled, the letters "CLn" are shown on the LED display.



### Clean mode set point

In clean mode, the fans that are used to provide minimum ventilation and the heaters operate according to the clean mode set point: heaters turn on when the room temperature is lower than the clean mode set point. Refer to section 5.1 to adjust the clean mode set point.

### Low temperature alarm

The controller can sound an alarm if the temperature gets too low while the controller is in clean mode. Refer to section 11.3 to set the clean mode alarm limit.

1. Select:

-  Main menu
-  Clean Mode

\* A password may be required to access this menu.

Clean Mode	
Clean Mode Status:	Off
Use Min Ventilation ?	No
Detect Lo Temperature?	Yes

2. Set the following parameters:

**Clean mode status** — Select "On" to enable the clean mode; select "Off" to disable it.



**Use minimum ventilation?** — Select "Yes" to activate minimum ventilation cycles during the clean mode. In addition, if 0-10V fans are used in minimum ventilation, these fans will also run at minimum intensity while the clean mode is on.

**Detect low temperature?** — Select "Yes" to enable the low temperature alarm limit or select "No" to disable this alarm condition.

## 4.11. Test Mode

The test mode is used to simulate temperature changes and to verify the controller's performances. When the test is enabled, all outputs of the controller operate according to the simulated temperature.

1. Select:

-  Main menu
-  Setup \*
-  Test Mode

\* A password may be required to access this menu.

Test mode	
Test Mode	Off
Temperature	72.3 °F

2. Set the following parameters:





**Test Mode** — Switch on the test mode status and then set the simulated temperature to the desired value.

 *The test automatically ends after 15 minutes of inactivity. It can also end sooner by switching the test mode status back to "Off".*

## 4.12. Version

This menu shows the version number of your controller program. This piece of information is useful to get technical support.

1. Select:

-  Main menu
-  Setup \*
-  User
-  Version

\* A password may be required to access this menu.



EXPERT WW	
Software	VX.X
<b>Atm Advanced</b>	
Version :	
Release :	
Model :	

## 5. TEMPERATURE & SET POINT SETTINGS

### 5.1. Temperature Set Point

The set point is a target temperature in the room. The activation of most outputs of the controller is based on this reference temperature.

1. Select:

-  Main menu
-  Set Points
-  Temp.

Set Points	
Set Points	
Current	75.5 °F
Day	70.0 °F
Night	75.5 °F
Clean Mode	35.0 °F
Outside	75.0 °F
Curve Offset	0.0 °F

Use ▼ to navigate

2. Set the following parameters:

 **Set point settings are common to all programs of the controller.**

**Current set point** — This is the current temperature set point in use. This value cannot be changed; to modify the set point, change the day or night set points below.

**Day set point** — Set the temperature set point that is used during the day (this set point is used all day long if the night set point is not enabled). The controller can also change the day set point automatically over time by using a curve (see section 5.3). *\*This parameter can only be modified while the temperature curve is inactive (sec. 5.3).*

**Night set point** — A different temperature set point can be used at night. The night set point can be used to lower the target room temperature for instance. The night set point is relative to the day set point, which means that it is automatically adjusted when the day set point changes. Set the night set point to the desired value. *\*This parameter is accessible if the night set point is enabled (see section 4.9).*



**Clean mode set point** — Select what is the target room temperature while the controller operates in clean mode.

**Outside set point** — The controller can adjust the moving speed of natural ventilation curtains as a function of outside temperature. When this function is used, the controller refers to the outside temperature set point to control the moving speed. Set the outside temperature to the desired value. *\*This parameter is accessible if the outside temperature sensor is enabled in section 4.7.1 and if the curtain compensation is enabled in the Installation Setup (section 4.5).*

### 5.2. Static Pressure Set Points

The high & low static pressure set points are the limits above and below which pressure-based air inlets (such as vent doors or tunnel doors) open or close. The controller allows using up to 3 different set point groups; each group starts at a user-defined fan stage. Refer to the Installation Setup section of this manual to enable the desired number of pressure set point groups.

1. Select:

-  Main menu
-  Set Points
-  Static Pressure\*

Set Points	
Set Points	
Low SP1 Set Point	.100 "WC
High SP Set Point	.140 "WC
Use at stage	MinV
Low SP2 Set Point	.060 "WC
High SP2 Set Point	.090 "WC
Use at stage	3
Low SP3 Set Point	.080 "WC
High SP3 Set Point	.100 "WC
Use at stage	5

Use ▼ to navigate

*\*This menu is accessible if at least one pressure-based air inlet output is enabled in the Installation Setup (sec. 4.5).*

2. Set the following parameters:

 **Static pressure set points must be defined separately for each program of the controller.**

**Low / High SP#x Set Point** — Set the low and the high static pressure set point of each group.

**Use at stage** — Set the fan stage at which each pressure set point group starts being used. Note that the 1st group automatically starts in minimum ventilation (or at stage 1 if minimum ventilation is not used). Also note that the controller automatically limits the stage at which each group starts so that the set point groups are activated one after the other (in numerical order).

## 5.3. Temperature Curve

### 5.3.1. Principle of Operation

A curve is composed of 10 steps. Each step specifies a day number and a temperature set point for that day (the day number refers to the animal age). Once the curve is activated, the controller changes the set point every hour in a linear fashion between consecutive steps of the curve. When the last step is reached, the controller keeps using the temperature set point associated to that day.

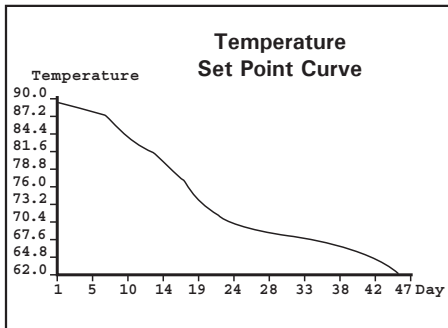

#### Notes

Certain restrictions apply to reduce the risk of errors:

1. The highest possible day number is 450.
2. Decreasing day numbers is not allowed.
3. All ten steps must be specified. If you don't need ten different steps, repeat the last temperature for each unnecessary step.

### 5.3.2. Settings

1. Select:

- Main menu
- Set Point
- SetP Curve\*

*\*A password may be required to access this menu. This menu is accessible if the temperature curve is enabled in the Installation Setup (sec 4.5).*

Temperature Curve Program 1	
Cur. Day	0 day
Set Point	70.0 °F
day 1	78.0 °F
day 10	75.0 °F
day 15	70.0 °F
day 20	65.0 °F
day 25	63.0 °F
day 30	61.0 °F
day 35	60.0 °F
day 40	60.0 °F
day 45	60.0 °F
day 50	60.0 °F
Status	Off

Use ▼ to navigate

The following parameters can only be modified while the curve is off.

If the curve is running, it is still possible to adjust the set point value of all curve steps simultaneously with the curve offset parameter (see sec. 5.3.3).

2. Set the following parameters:

**Current day** — This is the current age of the animals. This value may be changed to move backward or forward on the curve. A change in the current day also changes the animal age in the "Age & mortality" menu.

**Set point** — The day set point is displayed.

**Day numbers** — Set the day at which each step starts. The day number refers to the animal age. It is adjustable from -5 to 450 days. Negative values are used to prepare the house before letting the animals enter. *\*This parameter can only be modified while the curve is disabled.*

**Temperature set points** — Assign a temperature set point to each step of the curve. *\*This parameter can only be modified while the curve is disabled or with the curve offset function (sec. 5.3.3).*

**Status** — Select "Yes" to activate the curve. Once the curve is on, the controller automatically adjusts the set point automatically between consecutive points of the curve; for this reason, curve steps cannot be modified while the curve is running.

### 5.3.3. Modifying Curve Points

You can adjust the temperature set point associated to all curve points while the curve is running.

1. Select:

- Main menu
- Set Points
- Temp.

Set Points	
Set Points	
Current	75.5 °F
Day	70.0 °F
Night	75.5 °F
Clean Mode	35.0 °F
Outside	75.0 °F
Curve Offset	0.0 °F

Use ▼ to navigate

**Temperature curve offset** — Select the number of degrees that need to be removed or added to all set points of the temperature curve (+/- 10°F). *\*This parameter is accessible if the temperature curve is currently running.*

## 6. VENTILATION & COOLING

### 6.1. Minimum Ventilation

#### 6.1.1. Minimum Ventilation Cycles

**Definition:** Minimum ventilation cycles are activated when the room temperature is lower than the start temperature of the first fan stage. Running the fans even though ventilation is not required for reducing the room temperature is useful to reduce humidity levels and supply oxygen to the room. It also prevents the fans from freezing in winter.

**Minimum Ventilation Timer:** The minimum ventilation timer is composed of an “On Time” and of a “Cycle Time”. The fans run during the “On Time” and then stop until the end of the “Cycle Time”. This timer is common to all programs of the controller.

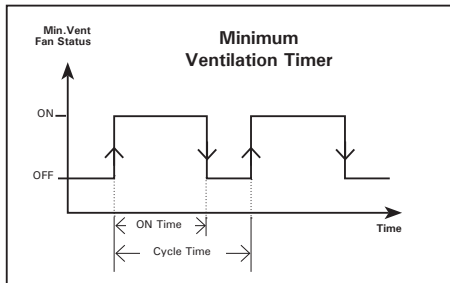

#### Minimum Ventilation Fans:

Minimum ventilation is ensured by a user-defined selection of On/Off fans. Refer to section 4.8.2 to select these fans.

#### Automatic Adjustment of the Minimum Ventilation Level:

The controller can automatically increase minimum ventilation rates over time by increasing the “On Time” portion of minimum ventilation cycles (refer to section 6.1.3).

#### 6.1.2. Minimum Vent. Settings

1. Select:

- Main menu
- Min Vent.

Minimum Ventilation	
Min Vent. Status	On
Minimum Ventilation Timer	
On time	15 sec
Cycle time	120 sec

2. Set the following parameters:

**Minimum ventilation status** — Select “On” to use minimum ventilation cycles or select “Off” to disable them.

**On Time** — Set the “On Time” of the minimum ventilation timer. Note that if the minimum ventilation curve is enabled, the controller automatically defines this value as a function of the animal age (see section 6.1.3). *\*This parameter can only be modified while the curve is inactive (sec. 6.1.3).*

**Cycle** — Set the “Cycle Time” of the minimum ventilation timer. Note that the “Cycle Time” must be longer than the “On Time”.

#### 6.1.3. Minimum Ventilation Curve

The controller can automatically adjust the “On Time” portion of the minimum ventilation timer with time. The minimum ventilation curve is composed of 10 steps and each step associates an “On Time” with an animal age. Once the curve is enabled, the controller changes “On Time” portion of the minimum ventilation cycles every hour in a linear fashion between consecutive steps of the curve. When it reaches the last step, the controller keeps using the last “On Time” associated with that day.

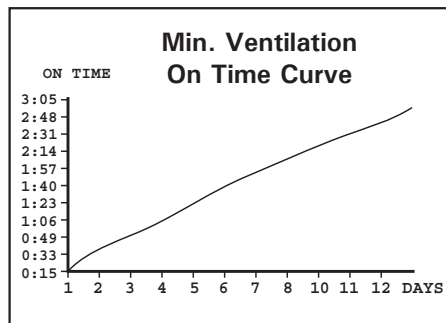

**Notes:** Certain restrictions apply to reduce the risk of errors:

- a) The highest possible day number is 450.
- b) Decreasing day numbers is not allowed.

c) All ten steps must be specified. If you don’t need 10 different steps, repeat the last “On Time” for each unnecessary step.

1. Select:

- Main menu
- Min. Vent.
- Vent Curve\*

*\* A password may be required to access this menu.*

Minimum Vent Curve Program 1		
Cur. Day	0 day	
On Time	15 sec	
day	1	15 sec
day	10	15 sec
day	15	15 sec
day	20	15 sec
day	25	15 sec
day	30	15 sec
day	35	15 sec
day	40	15 sec
day	45	15 sec
day	50	15 sec
Status		Off

Use ▼ to navigate

The following parameters can only be modified while the curve is off.

2. Set the following parameters:

(Refer to the previous section to get further information on these parameters)

**Current day** — This is the current age of the animals. This value may be changed to move backward or forward on the curve. A change in the current day also changes the animal age in the “Age & mortality” menu.

**On Time** — The current minimum ventilation fan “On Time” is displayed.

**Day numbers** — Set the day at which each step starts. The day number refers to the animal age and it is adjustable from -5 to 450 days. Negative values are used to prepare the house before letting the animals enter. *\*This parameter can only be modified while the curve is disabled.*

**On Time** — Assign a minimum ventilation “On Time” to each step of the curve. *\*This parameter can only be modified while the curve is disabled.*

**Status** — Select “On” to activate the curve. Once the curve is on, the controller automatically adjusts the “On Time” of minimum ventilation cycles between consecutive points of the curve; for this reason, curve steps cannot be modified while the curve is running.

## 6.2. Fan Stages

### 6.2.1. Principle of Operation

#### 6.2.1.1. Operation of Fan Stages

The controller has 12 fan stages which operate in a sequence to increase the level of ventilation as the room temperature increases. Each stage can activate on/off outputs and a combination of timer relays for cooling purposes. A fan stage is activated when the room temperature reaches its start temperature and is disabled when the room temperature decreases to its stop temperature.

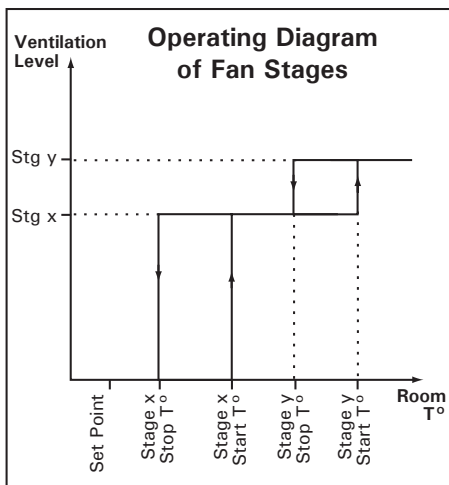

Start temperatures of fan stages are defined with respect to the set point and with respect to each other. This means that when one of these values is adjusted, all the consecutive values are adjusted by the same amount. For example, if the set point is increased by 1°F, the start temperature of all fan stages will be increased by the same amount.

#### Timer-based relays in fan stages

Fan stages can activate relays that operate following a timer (On and Off Times). This is useful to activate misting units in timer mode while a specific fan stage is active. Refer to section 4.8 to enable timer-based relays.

### 6.2.2. Stage 1 Ramping

The controller can gradually increase (or decrease) the running time of the fans to smooth out the transition from the minimum ventilation cycle to full operation of stage 1 fans.

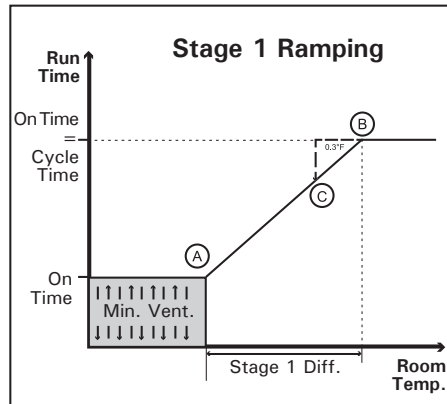

At room temperatures at or below the set point, the controller operates the fans of stage 1 according to the minimum ventilation cycle.

If the room temperature rises above the set point, a new "On Time" is calculated periodically as the temperature increases to allow a smooth progression (from point A to point B) up to full operation of the fans when the set point + differential is reached (when the "Off Time" becomes less than 15 seconds, it is fixed at 15 seconds until the temperature has reached the set point + differential. At that point, the fans of stage 1 operate continuously).

If the room temperature decreases 0.3°F below the set point + differential, the "On Time" value of the minimum ventilation cycle decreases gradually from a value equal to the total "Cycle Time" (point C) towards the regular "On Time".

**Ramping Settings:** To use the ramping function, enable the "Ramping on stage 1" function in the Installation Setup (section 4.5) and adjust the differential of stage 1 in section 6.2.3.

### 6.2.3. Fan Stage Settings

1. Select:

- Main menu
- Start/Stop\*
- Fan Stages

\*A password may be required to access this menu.

Fan Stage	Start / Stop
Stage 1 Start	70.0°F
Stage 1 Stop	69.0°F
Differential	2.0 °F
Stage 2 Start	72.0°F
Stage 2 Stop	71.0°F
Stage 3 Start	74.0°F
Stage 3 Stop	73.0°F
On Time	0:15m:s
Off Time	5:15m:s
Stage 4 Start	76.0°F
Stage 4 Stop	75.0°F
Stage 5 Start	78.0°F
Stage 5 Stop	77.0°F
Use ▼ to navigate	

2. Set the following parameters:

(Refer to the previous section to get further information on these parameters)

**Start & Stop temperatures** — Set the start and stop temperatures of each fan stage.

**The minimum difference between two consecutive start temperatures is of 0.5 °F (0.3 °C).**

**The start temperature of a fan stage must be greater value than its stop temperature.**

**Differential** — The differential is the temperature difference between the moment the Stage 1 start running in timer mode (stage 1 ramping) and the moment they run continuously. Refer to the diagram in section 6.2.2. The differential can be adjusted between 1.0°F and 10.0°F (0.6°C and 5.6°C). \*This parameter is accessible if the ramping option is enabled in the Installation Setup (section 4.5).

**Timer** — If timer-based relays are assigned to some fan stages (sec. 4.8), set the "On Time" and the "Off Time" of each timer-based relay. These "On & Off Times" can be adjusted from 0 to 15 minutes in increments of 15 seconds.

## 6.2.4. 0-10V Ventilation Outputs

The controller has a 0-10V output that can either be used to control air inlets or fans. To run this output, the controller refers to the average temperature reading of the probes that are being assigned to this output (sec. 4.7.3).

This section explains how 0-10V ventilation outputs work.

### 0-10V Mode: Automatic / Manual

You can manually control the intensity of a 0-10V output by using the manual control mode. While this mode is used, the controller stops controlling the output and lets you choose the intensity of the output.

### • If the 0-10V fans are used in minimum ventilation:

The 0-10V fans start at running at minimum speed when the average temperature of the output gets 0.5°F (0.3°C) higher than the “Stop Temperature”. They then keep running at minimum speed until the “Start Temperature” is reached. Once it is reached, the fans then start increasing in speed as the temperature rises. They finally reach their maximum intensity when the temperature reaches the “Max Output at” parameter setting.

Enable the “0-10V For Min Vent?” parameter in section 4.5 to use the 0-10V fan output this way.

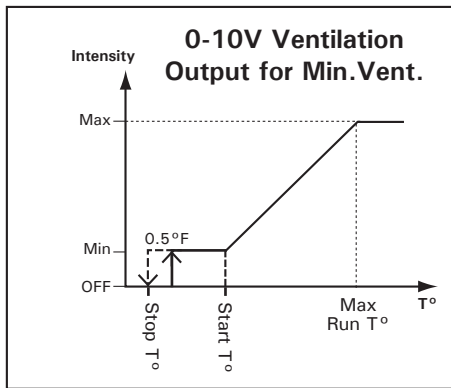

In addition, if 0-10V fans are used in minimum ventilation, these fans can also be used in clean mode. Refer to the Clean Mode chapter of this manual for further information (see section 4.10)

### • If the 0-10V fans are not used in min ventilation:

The 0-10V fans start at running at minimum speed when the average temperature of the output reaches the “Start Temperature”. The fans then increase in speed as the temperature rises and finally reach their maximum intensity when the temperature reaches the “Max Output at” parameter setting.

Disable the “0-10V For Min Vent?” parameter in section 4.5 to use the 0-10V fan output this way.

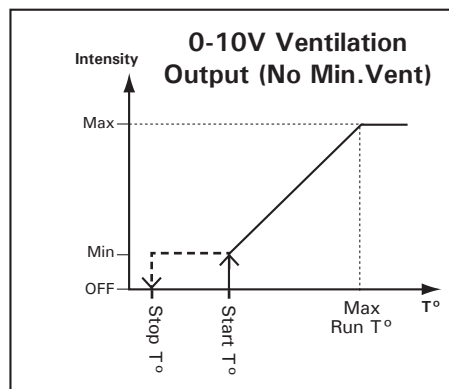

1. Select:

- Main menu
- Start/Stop\*
- 0-10V\*\*

\* A password may be required to access this menu.

\*\*This menu is accessible if a 0-10V ventilation output is enabled in the Installation Setup (section 4.5).

0-10V Output – Ventilation	
Mode	Automatic
Current output	100 %
Start temp.	70.0 °F
Min	40
Max	100
Max Output at	72.0 °F
Stop at	69.5 °F

Use ▼ to navigate

2. Set the following parameters:

**Mode** — Set the operating mode of the 0-10V output: select “Automatic” if you want the controller to control the output or select “Manual” to specify the intensity of the output yourself.

**Current output** — This is the current intensity of the output. This intensity can be modified while the manual mode is enabled above.

**Start temperature** — Set the start temperature to the desired value. This temperature can be set as a fix value (absolute) or it can be related to the set point: this means that when the set point changes, the start temperature is adjusted by the same amount. \*Refer to section 4.5 to specify if the start temperature of the 0-10V follows the set point or not.

**Minimum & max speeds** — Set the minimum and maximum speeds of the 0-10V output. The maximum speed must be greater than the minimum speed.

**Maximum output at** — Set the temperature at which the output reaches its maximum speed (this parameter must be set to a greater value than the start temperature).

**Stop at** — This is the temperature below which the 0-10V output stops.

### 6.3. Natural Ventilation Curtains

The controller can control 2 natural ventilation curtains. To operate these curtains, the controller refers to the average temperature reading of their assigned temperature probes (see sec. 4.7.3).

#### 6.3.1. Principle of Operation

The controller enters in natural ventilation when the average temperature of the probes that are assigned to a curtain reaches the "Initial Opening Temperature" of the curtain. At that moment, the curtain opens during its "Initial Opening Time".

When the natural ventilation mode is on, the natural ventilation curtain moves in timer mode: it opens according to its opening cycle ("Open Time" & "Off Time") when the average temperature rises above its opening temperature; likewise, it closes according to its closing cycle ("Close Time" & "Off Time") when the temperature falls below its closing temperature.

Natural ventilation is disabled when the average temperature decreases of 5°F (2.8°C) below the curtain's closing temperature or when tunnel ventilation starts (see graph below).

**Transition from tunnel to natural ventilation:**

When the temperature decreases below the start temperature of the first tunnel stage, the controller opens the curtain continuously during the "Continuous Opening Delay". When this delay has elapsed, it starts controlling the curtain using natural ventilation settings.

**Transition from natural to tunnel ventilation:**

When the natural ventilation curtain is opened and the room temperature reaches the start temperature of the first tunnel stage, the controller waits for the "Tunnel Close Delay" then fully closes the natural ventilation curtain.

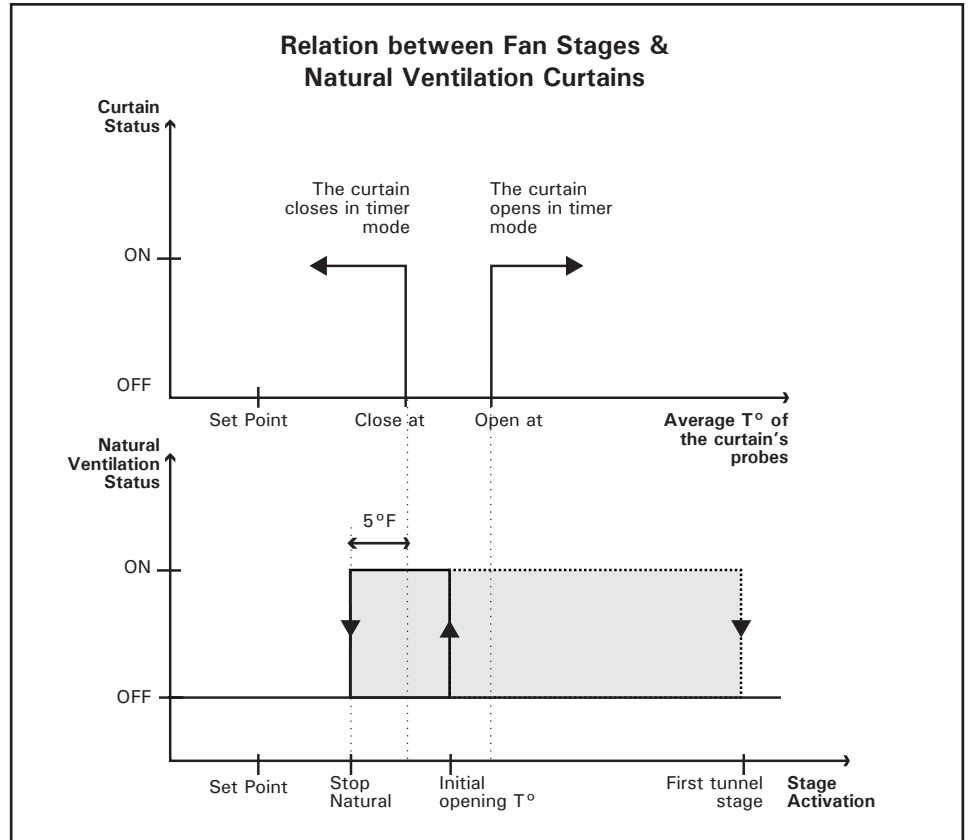

## 6.3.2. Transition Between Natural & Tunnel Vent.

### 1. From Natural to Tunnel Vent.

When the room temperature reaches the natural ventilation's start temperature, the natural curtain starts opening in timer mode [A] – if tunnel doors are used in natural ventilation, they open according to the same timer. When the room temperature reaches the start temperature of the first tunnel stage [C], the natural curtain stays still during the "Tunnel Close" delay and then fully closes. Here's how a tunnel door opens at the startup of tunnel ventilation:

#### 1. If the tunnel door was not used in natural vent.:

a) If the tunnel door operates according to the room temperature, the door reaches the position associated with the 1<sup>st</sup> tunnel stage when the controller enters in tunnel ventilation. The controller then starts the fans when the tunnel door reaches half the opening of that stage.

b) If the tunnel door operates according to the static pressure, the tunnel door opens during the "Pre-Opening Time" and then starts to be controlled as a function of static pressure. The controller starts the fans when half of the "Pre-Opening Time" has elapsed.

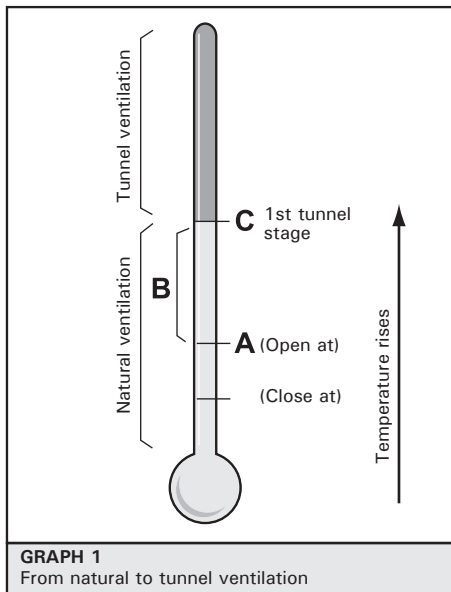

#### 2. If the tunnel door was used in natural vent.:

a) If the tunnel door operates according to the room temperature, the door fully opens at the start-up of tunnel ventilation and then goes the position associated with the 1<sup>st</sup> tunnel stage; this allows resetting the position of the actuator before entering in tunnel ventilation.

b) If the tunnel door operates according to the static pressure, the tunnel door opens during the "Pre-Opening Time" and then starts to be controlled as a function of static pressure.

### 2. From Tunnel to Natural Vent.

#### 1. If the tunnel door was not used in natural vent. :

When the controller re-enters in natural ventilation [A], the natural ventilation curtain opens during the "Continuous Open Delay" and the tunnel door fully closes. When this delay has elapsed, the natural curtain operates according to the natural ventilation timer [B].

#### 2. If the tunnel door was used in natural vent. :

When the room temperature falls below the natural ventilation's "Start Close at" temperature [A], the tunnel door and natural ventilation curtain open during the "Continuous Open Delay". When this delay has elapsed, both outputs operate according to the natural ventilation timer [B].

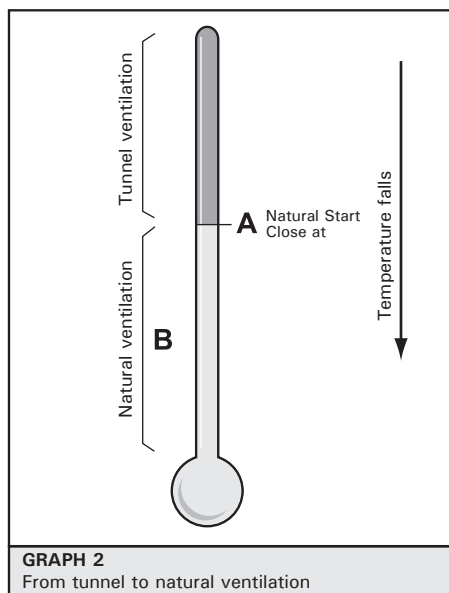

## 6.3.3. Natural Ventilation Settings

1. Select:

- Main menu
- Start/Stop\*
- Natural\*\*
- Curtain #X

\* A password may be required to access this menu.

\*\* This menu is accessible if at least 1 natural ventilation curtain is enabled in the Installation Setup (section 4.5).

Natural Curtain 1 Settings	
Initial Open at	80.0 °F
Start Close at	78.0 °F
Start Open at	82.0 °F
Initial Time	20 sec
Open Time	15 sec
Close Time	15 sec
Off Time	15 sec
Wind Delay	10 sec
Tun.Close Dly	300 sec
Continuous Open	300 sec
Purge Move Time	30 sec
Use ▼ to navigate	

2. Set the following parameters:

(Refer to previous sections to get further information on these parameters)

**Initial Open at** – Set the temperature at which the curtain opens for the first time. The curtain opens during its initial moving time at that moment.

**Start Close at** – Set the temperature below which the curtain starts closing in timer mode when the controller is in natural ventilation.

**Start Open at** – Set the temperature above which the curtain opens according to a timer when the controller is in natural ventilation.

**Initial Time** – The curtain opens during its initial opening time when the controller enters in natural ventilation. This opening time can be adjusted from 1 to 900 seconds (15 minutes).

**Open / Close / Off Time** – Set the opening and closing timers of the curtain (the "Off Time" is common to both cycles). The open and close times range from 1 to 900 seconds (15 minutes); the "Off Time" ranges from 0 to 900 seconds (15 minutes).

**Wind Delay** — When the controller is in natural ventilation and temperature falls below the *Start Close At* temperature or rises above the *Start Open At* temperature, the curtain only starts moving after the wind delay has elapsed. This way, the curtain does not move when wind drafts cause sudden temperature changes. Set the wind delay to the desired value. Adjustable from 0 to 300 seconds (5 minutes).

**Tunnel Close Delay** (*Factory Setting*) — This delay is launched at the beginning of the first tunnel stage. Once it has elapsed, the controller closes the natural ventilation curtain.

**Continuous Delay** (*Factory Setting*) — The natural ventilation curtain opens during this delay when the controller returns in natural ventilation (when tunnel ventilation ends).

**Purge move time** — This is the amount of time required to open the curtain during a purge cycle (see sec. 6.3.6). Set this parameter separately for each curtain. *\*This parameter is accessible if the purge option is enabled in the Installation Setup (section 4.5).*

### 6.3.4. Curtain Compensation

The controller can slightly adjust opening of the curtains as a function of outside temperature: as the outside temperature increases, the controller increases the opening time of the curtains. As a result, curtains open faster when the outside temperature gets warm. Likewise, when the outside temperature gets cold the controller increases the closing time of the curtains. This compensation is optional. To use it, enable the curtain compensation in the Installation Setup (section 4.5). Then, set the outside temperature set point (sec. 5.1).

#### When temperature rises:

When the curtain opens, the controller increases the curtain's "On Time" by 4% for every 1°F (0.6°C) in the compensation interval (i.e. an interval of 3°F means a 12% increase). The curtain's "Off Time" is decreased by the same amount.

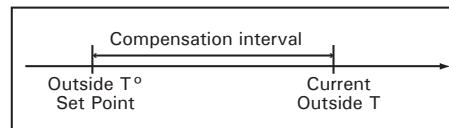

#### When temperature falls:

When the curtain closes, the controller increases the curtain's "On Time" by 4% for every 1°F (0.6°C) in the compensation interval (i.e. an interval of 3°F means a 12% increase). The curtain's "Off Time" is decreased by the same amount.

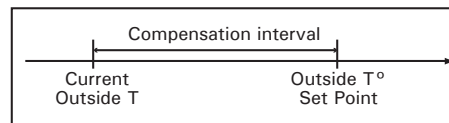

### 6.3.5. Stopping the Fans in Natural Vent.

**Whisker switches** are used to stop some on/off fan outputs when the controller is in natural ventilation (refer to section 4.8 to select what fan relays must turn off in natural ventilation). These switches tell when the curtains are sufficiently opened.

#### When temperature rises (point A on the graph)

The controller gradually opens the curtain as temperature rises. It can also disable a chosen selection of fans when the curtain is sufficiently opened (when the curtain has reached its whisker switch).

#### When temperature falls (point B on the graph):

At point B, the curtain is already opened and the fans are stopped. The controller gradually closes the curtain as temperature falls. The controller restarts the fans when the curtain closes and releases its whisker switch.

**Security:** If the temperature drops suddenly or if the whisker switch is defective, the controller automatically restarts the fans when the temperature falls 5°F (3°C) below the lowest curtain's closing temperature. When this situation occurs, a defective whisker switch alarm is posted to the alarm log.

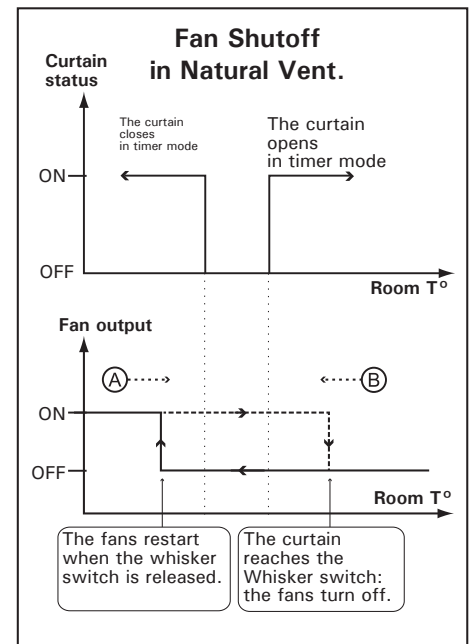

## 6.3.6. Purge

The purge function allows opening natural ventilation curtains on a short period of time to purge the air continuously.

**Principle of operation:** When a purge cycle starts, both curtains open during their respective "Purge Move Time". They then stay still during the "Purge Time". When this delay has elapsed, both curtains return to their initial position until the beginning of the next purge cycle.

### Frequency of the purge cycles

The frequency of purge cycles is determined by the "Purge Cycle Time". A new purge cycle starts after that time delay has elapsed.

 **Purge cycles are not performed while the controller is in tunnel ventilation.**

 **Refer to section 6.3.3 to set the amount of time each curtain need to open during a purge cycle (Purge Move Time).**

1. Select:

-  **Main menu**
-  **Start/Stop\***
-  **Natural\*\***
-  **Purge \*\*\***

\* A password may be required to access this menu.

\*\* This menu is accessible if at least 1 natural ventilation curtain is enabled in the Installation Setup (section 4.5).

\*\*\*This menu is accessible if the purge option is enabled in the Installation Setup (section 4.5).

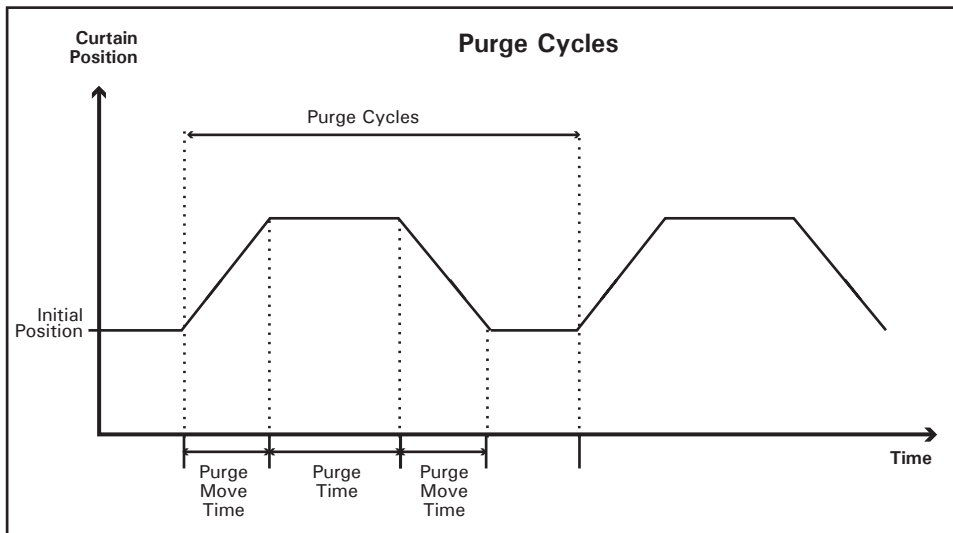

Purge Settings	
Purge Time	15 sec
Purge Cycle	180 min

2. Set the following parameters:

**Purge Time** — Once they are opened, curtains stay still during this amount of time before returning to their initial position. Set the "Purge Time" to the desired value.

**Purge Cycle** — This the amount of time that separates two purge cycles. The cycle includes the "Purge Move Time" (sec. 6.3.3) and the "Purge Time". Set it to the desired value.

## 6.4. Tunnel Doors

The controller can control the opening of 2 tunnel doors as a function of the static pressure level or as a function of the average temperature in the room. Refer to section 4.5 of this manual to choose the proper operating mode.

### 6.4.1. Pressure-based Tunnel Doors

**Beginning of tunnel ventilation:** The activation of tunnel ventilation is linked with the activation of a user-defined fan stage: when the start temperature of that fan stage is reached, the controller starts controlling tunnel doors according to the static pressure level. It opens the doors when the pressure level exceeds the high pressure set point and closes them when the pressure level is

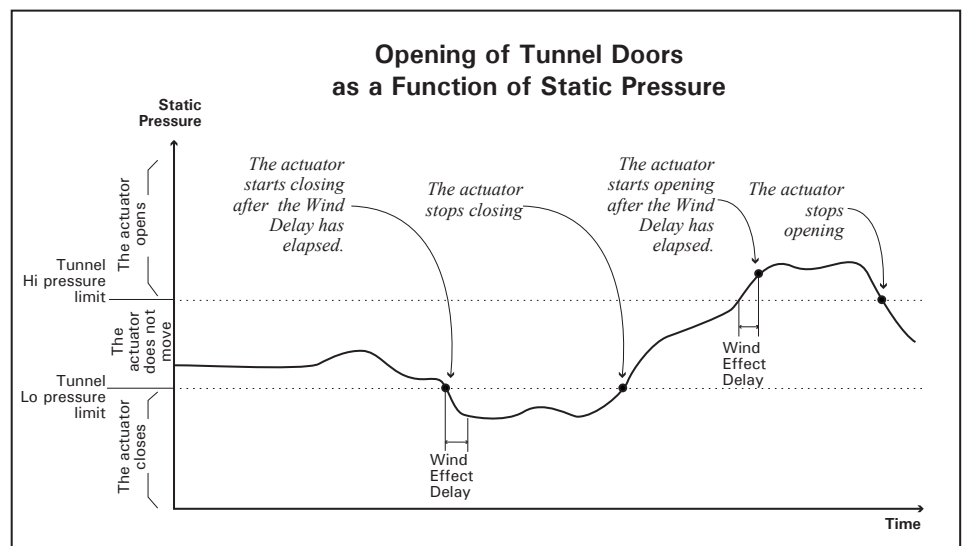

lower than the low pressure set point. Refer to the chapter 5 to set the static pressure set points.

**Minimum outside temperature:** A minimum outside temperature can be specified to avoid entering in tunnel ventilation when it is too cold outside. This feature is optional and can only be used if an outside temperature probe is enabled (sec. 4.7.1).

**Minimum age:** A minimum age can be specified to avoid entering in tunnel ventilation when the animals are too young. This feature is optional and can only be used if age-based functions are enabled in the Installation Setup (section 4.5).

**Pre-opening:** The pre-opening delay is used to slightly open tunnel doors before the activation of tunnel fans. The pre-opening is performed at the start-up of tunnel ventilation (i.e., when the fan stage which activates tunnel ventilation starts).

**Wind effect delay:** When the pressure level exceeds the high or low static pressure set point, tunnel doors wait for the end of the "Wind Effect Delay" before moving. Tunnel doors will only move if the high or low pressure condition is still valid after the delay has elapsed. This way, tunnel doors do not move if a wind draft causes fleeting changes in the pressure level.

**Closing vent doors (inlets) in tunnel ventilation:** If vent doors (inlets) remain opened in natural ventilation, you must define the tunnel stage at which they must close.

**6.4.2. Temperature-Based Tunnel Doors**

**Beginning of tunnel ventilation:** The activation of tunnel ventilation is linked with the activation of a user-defined fan stage: when the start temperature of that fan stage is reached, the controller opens tunnel doors during the opening time associated with that stage. The controller then activates tunnel fans when half of the opening time has elapsed. The activation of every consecutive fan stages causes the tunnel door to open further.

**Minimum age:** A minimum age can be specified to avoid entering in tunnel ventilation when the animals are too young. This feature is optional and can only be used if age-based functions are enabled in the Installation Setup (section 4.5).

**Minimum outside temperature:** A minimum outside temperature can be specified to avoid entering in tunnel ventilation when it is too cold outside. This feature is optional and can only be used if an outside temperature probe is enabled (sec. 4.7.1).

**Opening Times:** The user must associate an opening of the tunnel door to each tunnel fan stage. When a tunnel fan stage starts, tunnel doors open according to the opening time associated to that stage. Opening times are set separately for each tunnel door.

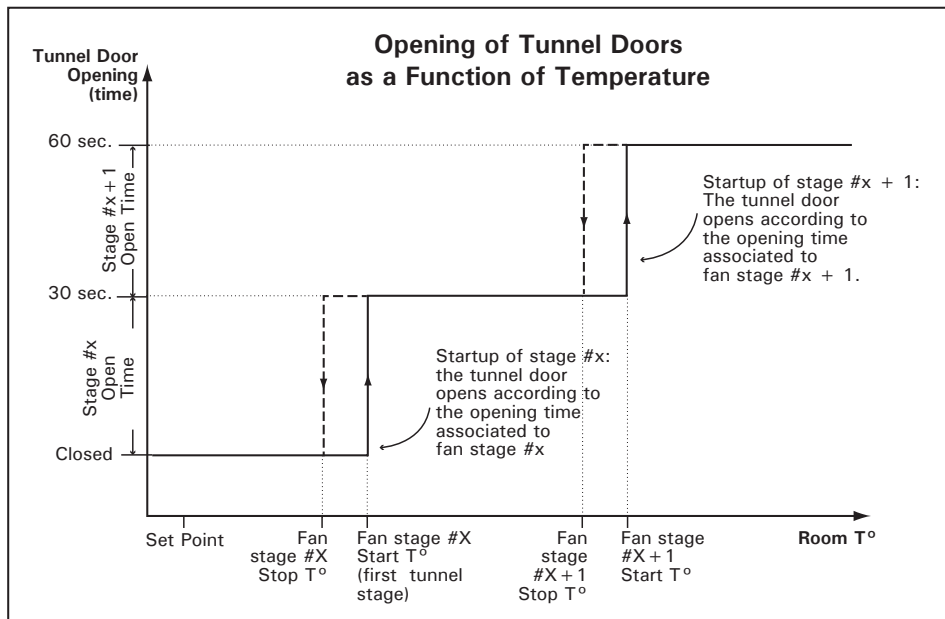

**Closing vent doors (inlets) in tunnel ventil.:** If vent doors (inlets) remain opened in natural ventilation, you must define the tunnel stage at which they must close.

**Reference temperature in tunnel ventilation**  
The selection of probes that is used to measure the room temperature can be changed in tunnel ventilation to compensate for changes in airflow patterns that can distort the room temperature calculation. The user must select at what fan stage the second probe set starts being used.



## 6.4.3. Tunnel Door Settings

1. Select:

-  Main menu
-  Start/Stop\*
-  Tunnel\*\*

\* A password may be required to access this menu.

\*\* This menu is accessible if at least one tunnel door is enabled in the Installation Setup and if (section 4.5).

Tunnel Settings	
First Stage:	5
Probe Set 2 at Stage:	5
Close Vents at Stage	4
Min. Outdoor Temp.	40.0 °F
Minimum Age:	50 day
Tunnel 1 Run Time	900 sec
Tunnel 1 Opening Time	
Stage 5	30 sec
Stage 6	30 sec
Stage 7	30 sec
or	
Tunnel 1 :	
PreOpening	45 sec
Wind Effect Delay	0:30m:s

2. Set the following parameters:

(Refer to the previous section to get further information on these parameters)

**First stage** — Both tunnel doors start opening when the start temperature of this fan stage is reached. Select what fan stage signals the beginning of tunnel ventilation.

**Probe set 2 starts at stage** — Select at what fan stage the controller starts measuring the room temperature with the second probe set.

**Closing vent doors** — Select the fan stage at which vent doors must close. *\*This menu is only available if vent doors are not closed in natural ventilation (see Installation Setup in section 4.5).*

**Minimum outdoor temperature** — Select the outside temperature below which both tunnel doors remain closed. *\*Available if an outside temperature probe is enabled (section 4.7.1).*

**Minimum age** — Select the animal age below which both tunnel doors remain closed. Adjustable from 1 to 450 days (or select *Off* to disable this function). *\*Available if age-based functions are enabled in the Installation Setup (section 4.5).*

### Temperature-based Tunnel Doors:

**Run Time** — Specify the maximum run time of the tunnel's actuator.

**Opening times** — Assign a tunnel door opening time with the start-up of each tunnel fan stage. If two tunnel doors are used, assign these opening times separately for each tunnel door. Note that the sum of all opening times cannot exceed the "Run Time" parameter. *\*Available if tunnel doors operate according to the temperature.*

### Pressure-based Tunnel Doors:

*If two tunnel doors are used, set the following parameters separately for each of them:*

**Pre-opening delay** — Set the time that is required to pre-open the door before activating tunnel fans. *\*Adjustable from 0 to 120 seconds.*

**Wind effect delay** — Select what time delay the controller must wait prior to moving tunnel doors when the pressure level exceeds a pressure set point.

## 6.5. Vent Doors (Inlets)

The controller can control the opening of two vent door (inlet) outputs. These vent doors (inlets) either open and close as a function of temperature or as a function of static pressure.

If they operate as a function of temperature, the first vent door (inlet) output can also use a potentiometer or can operate in timer mode (whereas the second output can only run in timer mode).

The following sections explain how vent doors (inlets) operate depending on their operating mode:

1. Temperature-based, using a potentiometer
2. Temperature-based, using a timer
3. Static pressure-based.

Set the operating mode of vent doors (inlets) in the Installation Setup (section 4.5).

### 6.5.1. Timer-based Vent Doors (Inlets)

#### 6.5.1.1. Principle of Operation

When timer-based vent doors (inlets) are used, you must first specify the total time that is required to open each actuator. Then, you must associate an opening with the start-up of each fan stage (openings are defined as a percentage of the total opening time). As the room temperature increases and new stages are activated, vent doors (inlets) will open or close accordingly.



**Vent door (inlet) opening in minimum ventilation:** Vent doors (inlets) are at their “Closed” position during the “Off Time” portion of minimum ventilation cycles; during the “On Time” portion, they open to the position associated with stage 1.

**Over-opening:** A supplementary stage can be defined in order to continue opening vent doors (inlets) beyond the activation temperature of the last ventilation stage. This over-opening stage is used to direct the airflow more efficiently during periods of warm weather. When all reference points of ventilation stages are defined, the user can specify the temperature at which vent doors (inlets) reach their over-opening position (Start T° of the last stage + over-opening bandwidth).

**Closing Vent Doors (Inlets):** Vent doors (inlets) can either close when the controller enters in natural ventilation or when the controller reaches a user-defined tunnel ventilation stage. Refer to the Installation Setup chapter to close vent doors in natural ventilation (section 4.5) or refer to section 6.4.3 to choose at what tunnel stage vent doors (inlets) must close.

#### 6.5.1.2. Vent Door Settings

1. Select:

-  Main menu
-  Vent/Inlet\*
-  Vent door/ Inlet 1 is already displayed; press Vent door/ Inlet 2 to display parameter settings of the second inlet.

*\*This menu is accessible if at least one vent door (inlet) output enabled in the Installation Setup (section 4.5). A password may also be required to access this menu (section 4.2).*

 Make sure you have selected a timer-based vent door (inlet). Refer to section 4.5 to set vent door (inlet) functions.

 Vent door (inlet) openings are defined as a percentage of their total opening time.

Vent Door/ Inlet 2	Vent Door/Inlet 1 Settings	
Auto-Reset	Position	0 %
	Test Mode	72.3 °F
	Openings	
	Closed	0 %
	Stage 1	10 %
	Stage 2	20 %
	Stage 3	30 %
	Stage 4	40 %
	Stage 5	50 %
	Stage 6	60 %
	Stage 7	70 %
	Stage 8	80 %
	Over Opening settings	
	Opening	100 %
	Bandwidth	5.0 °F
	Total Opening Time	2:00 m:s

2. Set the following parameters:

**Position** — This is the current position of the selected vent door (inlet). This value cannot be modified.

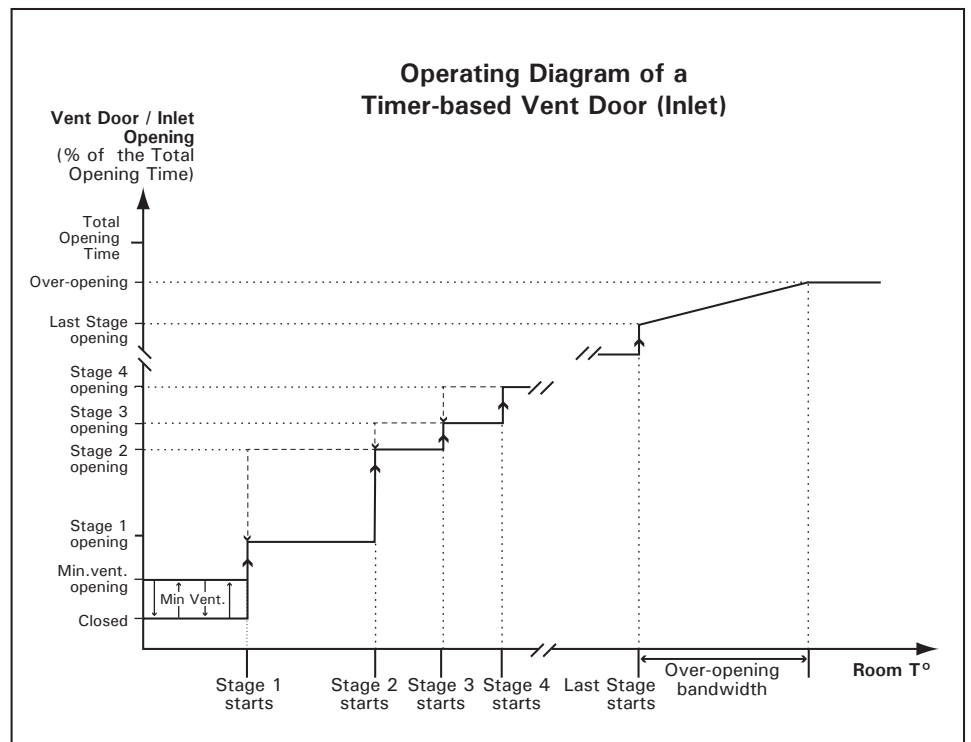

**Test mode** — This is the room temperature that is used in test mode. This value can only be modified in the “Test Mode” menu (see section 4.11).

**Closed** — This is the position of the vent door (inlet) during the “Off Time” portion of minimum ventilation cycles. Set this position to the desired value.

**Stage #x** — Assign a vent door (inlet) opening to each fan stage in use (in %).

**Over-Opening Settings:**

**Opening** — Assign a vent door (inlet) position to the over-opening stage.

**Bandwidth** — Set the temperature range over which the vent door (inlet) gradually opens from the position associated with the last fan stage towards the over-opening position (see previous graphic).

**Total opening time** — Enter the **exact time** that is required to reach the actuator’s maximum limit switch. The controller will limit the opening of the vent door (inlet) according to this parameter value. *\*This parameter is accessible if at least one timer-based vent door (inlet) is enabled in the Installation Setup (sec. 4.5). [This parameter is common to all programs]*

### 6.5.1.3. Actuator Reset

The controller needs to reset the actuator’s position at regular intervals to make sure the vent door (inlet) position is always accurate. This reset is performed automatically according to one of these two methods:

**1. Reset the minimum position only**

**(Close mode):** Each time a reset is performed, the vent door (inlet) totally closes. Once the actuator’s position is reset, the vent door (inlet) returns to its previous position. The “Close” pilot light of the vent door (inlet) flashes while the actuator is closing.

**2. Reset toward the nearest position (Open/Close mode):** If the current inlet position is higher than 50% at the reset time, the controller fully opens the vent door (inlet) to reset the actuator’s position; if the current vent door (inlet) position is lower than 50%, the controller closes the actuator to perform the reset. This way, the vent door (inlet) never closes when the room temperature already asks for a wide

opening. The “Open” or “Close” pilot light of the vent door (inlet) output flashes while the actuator opens or closes.



**Make sure limit switches are located at both ends of the actuators when using this resetting method.**

1. Select:



**Main menu**



**Vent/Inlet\***



**Auto Reset\***

*\* This menu is accessible if at least one vent door (inlet) output enabled in the Installation Setup (section 4.5). A password may also be required to access this menu (section 4.2).*

*\*\* This menu is accessible if at least one timer-based vent door (inlet) is enabled in the Installation Setup (section 4.5).*



**The following parameters are common to all programs and to all timer-based vent doors (inlets).**

Auto Reset Settings	
Inlet Reset Mode	Op/Cl
Inlet Reset Now?	No
Day Time	6:00A h:m
Period	3 day
Reset Delay	2:00 m:s

**Vent / Inlet reset mode** — Select the desired reset mode: “Op/Cl” to reset the actuator toward its nearest position; select “Close” to reset the actuator toward its closed position only or select “Off” to disable the automatic reset.

**Vent / Inlet reset now?** — Select “Yes” to reset the actuator’s position now.

**Day time** — Set the time of day at which resets are performed.

**Period** — Set the frequency of inlet resets. A reset can be performed once every 1-7 days.

**Reset delay** — During a reset, the controller opens or closes the actuator during the Reset Delay or up until a limit switch is reached. The Reset Delay should be set to the same time value or higher than the total opening time of the actuator (as defined in section 6.5.1.2).

## 6.5.2. Potentiometer-based Vent Doors (Inlets)

### 6.5.2.1. Principle of Operation

When potentiometer-based vent doors (inlets) are used, you must associate a vent door (inlet) opening with the start-up of each fan stage. As the room temperature increases and new stages are activated, vent doors (inlets) will open or close accordingly.

**Inlet opening in minimum ventilation:** The vent door (inlet) is at its “Closed” position during the “Off Time” portion of minimum ventilation cycles; it opens to the position associated with stage 1 during the “On Time”.

**Over-opening:** A supplementary stage can be programmed in order to continue opening the vent door (inlet) beyond the activation temperature of the last ventilation stage. This over-opening stage is used to direct the airflow more efficiently during periods of warm weather. When all reference points of ventilation stages are defined, the user can specify the temperature at which the vent door (inlet) reaches its over-opening position (Start T° of the last stage + over-opening bandwidth).

**Closing Vent Doors (Inlets):** Vent doors (inlets) can either close when the controller enters in natural ventilation or when the controller reaches a user-defined tunnel ventilation stage. Refer to the Installation Setup chapter to close vent doors in natural ventilation (section 4.5) or refer to section 6.4.3 to choose at what tunnel stage vent doors (inlets) must close.

**Security function:** If the potentiometer is defective, the controller will operate in security mode: if the room temperature is 2°F (1.1°C) above the set point, the vent door (inlet) opens according to the following cycle: 8 seconds ON, 60 seconds OFF. If the room temperature is 2°F (1.1°C) below the set point, the vent door (inlet) closes according to the same cycle.

### 6.5.2.2. Vent Door Settings

1. Select:

-  Main menu
-  Vent/Inlet\*
-  Vent door / Inlet 1 is already displayed.

*\* This menu is accessible if at least one vent door (inlet) output enabled in the Installation Setup (section 4.5). A password may also be required to access this menu (section 4.2).*

 **Make sure vent door (inlet) output 1 uses a potentiometer. Refer to section 4.5 to set the vent door (inlet) mode. (Note that the second vent door (inlet) output cannot use a potentiometer).**

2. Set the following parameters:  
(Refer to the previous section to get further information on these parameters)

**Position** — This is the current position of the selected vent door (inlet). This value cannot be modified.

**Test mode** — This is the room temperature that is used in test mode. This value can only be modified when the test mode is enabled (see section 4.11).

Vent Door/ Inlet 2	Vent Door /Inlet 1 Settings	
Position	0 %	
Auto Reset	Test Mode	72.3 °F
Calib.	Openings	
	Closed	0 %
	Stage 1	10 %
	Stage 2	20 %
	Stage 3	30 %
	Stage 4	40 %
	Stage 5	50 %
	Stage 6	60 %
	Stage 7	70 %
Stage 8	80 %	
Over Opening settings		
	Opening	100 %
	Bandwidth	5.0 °F

**Closed** — This is the position of the vent door (inlet) during the “Off Time” portion of minimum ventilation cycles. Set this position to the desired value.

**Stage #x** — Assign a vent door (inlet) opening (in %) with each fan stage in use.

**Over-Opening Settings:**

**Opening** — Assign a vent door (inlet) position to the over-opening stage.

**Bandwidth** — Set the temperature range over which the vent door (inlet) gradually opens from the position associated with the last fan stage towards the over-opening position).

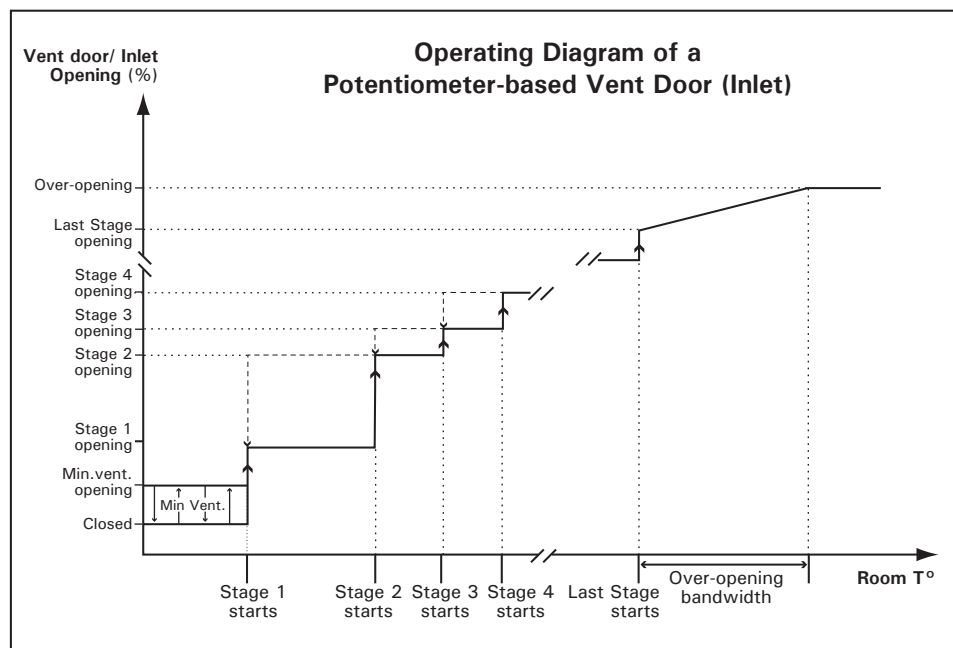



### 6.5.2.3. Vent Door Calibration

If vent door (inlet) output 1 uses a potentiometer, the actuator connected to this output must be calibrated. This calibration tells the controller what are the minimum and maximum positions of the vent door (inlet):

Minimum calibrated position=opening of 0%  
Max. calibrated position=opening of 100%

1. Select:

-  Main menu
-  Vent/Inlet\*
-  Calib\*\*

\* This menu is accessible if at least one vent door (inlet) output enabled in the Installation Setup (section 4.5). A password may also be required to access this menu (section 4.2).

\*\* This menu is accessible if vent door (inlet) output 1 uses a potentiometer (sec. 4.5).

2. Set the following parameters:  
(Refer to the previous section to get further information on these parameters).

Vent Door/Inlet 1 Calibration	
.....	Save Minimum Position? Yes
.....	Save Maximum Position? No
.....	

#### Save minimum position?

– To calibrate the minimum position, use the “Close” switch to close the vent door (inlet) to its minimum position. Once it is closed, set the switch to “Off” to stop the actuator.

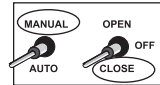

Now that the actuator is closed, answer “Yes” to the “Save minimum position?” question on screen. Once the “Yes” answer is posted, the controller switches the answer back to “No”; the minimum position is now saved.

#### Save maximum position? –

To calibrate the maximum position, use the “Open” manual control switch to fully open the vent door. Once the maximum opening is reached, set the manual control switch to “Off” to stop the actuator.

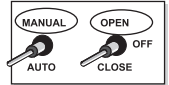

Now that the actuator is opened, answer “Yes” to the “Save maximum position?” question on screen. Once the “Yes” answer is posted, the controller switches the answer back to “No”; the maximum position is now saved.

3. Once the calibration is completed, set the manual control switch back to the “Auto” position to enable the automatic control of the vent door.

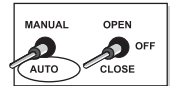

**!** For best results, make sure at least 12 inches (30 cm) separates the minimum actuator’s position from its maximum position.

### 6.5.3. Static Pressure-Based Vent Doors (Inlets)

#### 6.5.3.1. Principle of Operation

Static-pressure-based vent doors (inlets) open or close as a function of the static pressure level in the room. They open when the static pressure level exceeds the high pressure set point or close when the static pressure level is lower than the low pressure set point. The graph below illustrates this process. Refer to chapter 5 to set the static pressure set points.

#### Wind Effect Delay

When the pressure level exceeds the high or low static pressure set point, vent doors (inlets) wait for the end of the *Wind Effect Delay* before moving. They will only move if the high or low pressure condition is still valid after the delay has elapsed. This way, vent doors (inlets) do not move if a wind draft causes fleeting changes in the pressure level.

**Pre-Opening Delay:** In minimum ventilation, vent doors (inlets) open during the “Pre-opening Delay” before the controller starts the fans.

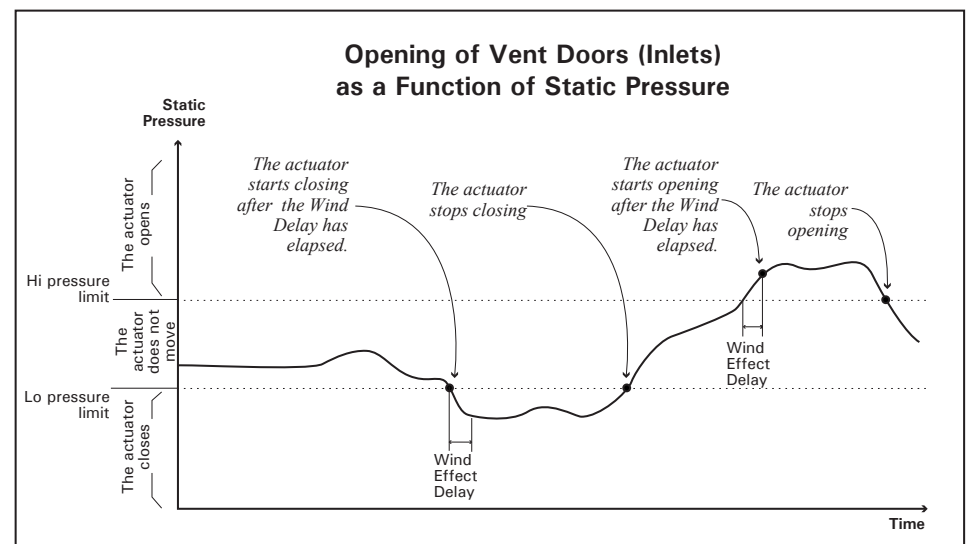

**Closing Vent Doors (Inlets):** Vent doors (inlets) can either close when the control-

ler enters in natural ventilation or when the controller reaches a user-defined tunnel ventilation stage. Refer to the Installation Setup chapter to close vent doors in natural ventilation (section 4.5) or refer to section 6.4.3 to choose at what tunnel stage vent doors (inlets) must close.



## 6.5.3.2. Vent Door Settings

1. Select:

-  Main menu
-  Vent/Inlet\*
-  Vent door / Inlet 1 is already displayed. Press Vent door / Inlet 2 to display parameter settings of the second inlet.

*\* This menu is accessible if at least one vent door (inlet) output enabled in the Installation Setup (section 4.5). A password may also be required to access this menu (section 4.2).*

Vent Door / Inlet 1 Settings	
Wind Effect Delay	0:30 m:s
PreOpening	15 sec

 **Make sure you have selected a static-pressure-based vent door (inlet). Refer to section 4.5 to set vent door (inlet) functions.**

2. Set the following parameters:

(Refer to the previous section to get further information on these parameters).

**Wind Effect Delay** — Select what delay must elapse before moving the vent door (inlet) when the pressure level exceeds a pressure set point.

**Pre-opening Delay** — Set the time that is required to pre-open the vent door (inlet) before activating minimum ventilation fans. Adjustable from 0 to 120 seconds.

## 6.6. 0-10V Air Inlet

The first 0-10V output of the controller can either be used to control an air inlet or variable-speed fans. This output operates according to the average temperature of its assigned temperature probes (see sec. 4.7.3).

A 0-10V air inlet works exactly the same as a potentiometer-based air inlet but does not need to be calibrated.

### 0-10V Mode: Automatic / Manual

You can manually control the opening of a 0-10V output by using the manual control mode. While this mode is used, the controller stops controlling the output and lets you choose the inlet opening.

1. Select:

-  Main menu
-  Start/Stop\*
-  0-10V\*\*

*\* A password may be required to access this menu.*

*\*\*This menu is accessible if a 0-10V inlet output is enabled in the Installation Setup (section 4.5).*

0-10V Output #X Inlet	
Mode	Automatic
Opening	30 %
Closed	0 %
Stage 1	10 %
Stage 2	20 %
Stage 3	30 %
Over Opening settings	
Opening	100 %
Bandwidth	5.0 °F

Use ▼ to navigate

2. Set the following parameters:

 **0-10V inlets work as potentiometer-based inlets. Refer to section 6.5.2 to see how they work and to get information about the following parameters.**

**Mode** — Set the operating mode of the 0-10V output: select “Automatic” if you want the controller to control the output according to specified parameter settings below or select “Manual” to specify the inlet opening manually.

**Opening** — This is the current opening of the air inlet. This opening can be changed when the manual mode is enabled above.

**Closed** — This is the position of the air inlet during the “Off Time” portion of minimum ventilation cycles. Set this position to the desired value.

**Stage #x** — Assign an inlet opening (in %) to each fan stage in use.

### Over-Opening Settings:

**Opening** — Assign an inlet position to the over-opening stage.

**Bandwidth** — Set the temperature range over which the inlet gradually opens from the position associated with the last fan stage towards the over-opening position (see graph in section 6.5.2).

## 6.7. Cool Cell

The controller can control one cool cell output. This cooling system reduces the air temperature by evaporation of water into the air stream.

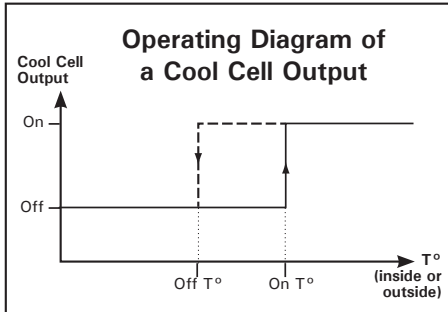

**Principle of operation:** The cool cell output can either operate according to the inside temperature or outside temperature: it starts running in timer mode when the inside (or outside) temperature rises and reaches the output's start temperature; the output stops when temperature falls below a user-defined value. It can also stop when humidity levels are too high (see RH Compensation in chapter 10).

**Start/Stop Temperatures:** If the cool cell output operates according to the inside temperature, its start and stop temperatures are related to the set point; this means they are automatically adjusted when the set point changes. That is not the case if cool cells operate according to the outside temperature.

**Operating Time Range:** The user can specify a time range during which the cool cell output can run. This allows deactivating the output at night for instance.

**Cool Cell LED:** The cool cell LED located on the faceplate of the controller tells the status of cooling cycles:

LED is Off: the cool cell output is off  
 LED is On: the cool cell output is on

## Settings

1. Select:

- Main menu
- Start/Stop\*
- Cool Cell\*\*

\* A password may be required to access this menu.  
 \*\* This menu is accessible if the cool cell output is enabled in the Installation Setup (section 4.5).

Cool Cell Settings	
Temperature	Inside
On Temperature	85.0 °F
Off Temperature	83.0 °F
On Time	15 sec
Off Time	900 sec
Start at	6:00A h:m
Stop at	9:00P h:m
Use ▼ to navigate	

2. Set the following parameters:

**Temperature** — Select “inside” if the operation of cool cells is based on the inside temperature; select “outside” if it is based on the outside temperature.

**On temperature** — Select the temperature (inside or outside T°) at which the cool cell output starts.

**Off temperature** — Select the temperature (inside or outside T°) below which the cool cell output stops.

**On & Off times** — Set the “On & Off Times” of the cool cell timer.

**Start & stop at** — Specify the period of time over which the output can run.

## 6.8. Misting Output

The controller can control one misting output. When the room temperature reaches the start temperature of the output, mist units are activated and run in timer mode according to their minimum timer (Min On Time & Min Off Time). Then, as temperature rises, a gradual transition is made from the minimum timer towards the maximum timer (Max On Time & Max Off Time). The second mist timer is fully used when the room temperature reaches the Maximum Temperature parameter setting. The misting output is disabled when the temperature falls below a user-defined value. It can also stop when humidity levels are too high (see RH Compensation in chapter 10).

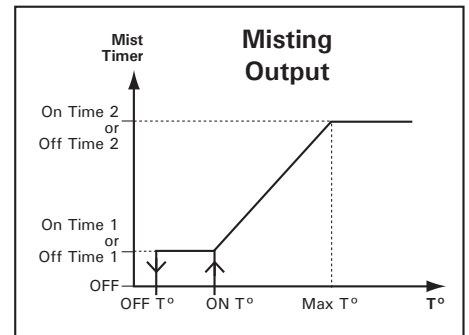



**Start / stop temperatures:** Operating temperatures of the mist output can either be related to the set point – which means the controller automatically adjusts them when the set point changes – or they can be set as absolute values. Refer to the Installation Setup chapter to choose if the output follows the set point or not (sec. 4.5).

**Operating time range:** You can specify a period of time over which the mist output is allowed to run. This allows deactivating the mist output at night for instance.

**Mist LED:** The Mist LED located on the faceplate of the controller tells the status of misting cycles:

LED is Off: The mist output is off  
 LED is On: The mist output is on

1. Select:

-  Main menu
-  Start/Stop\*
-  Misting \*\*

Misting Settings	
On Temperature	85.0 °F
Off Temperature	83.0 °F
Minimum On Time	15 sec
Minimum Off Time	900 sec
Maximum Temperature	87.0 °F
Maximum On Time	180 sec
Maximum Off Time	900 sec
Start at	6:00A h:m
Stop at	9:00P h:m

Use ▼ to navigate

\* A password may be required to access this menu.  
 \*\* This menu is accessible if the misting output is enabled in the Installation Setup (section 4.5).

2. Set the following parameters:

**On temperature** — Select the temperature at which the misting output starts.

**Off temperature** — Select the temperature below which the misting output stops.

**Minimum On & Off times** — Set the on & off times of the minimum misting timer.

**Maximum Temperature** — Set the temperature at which the maximum misting timer if used.

**Maximum On & Off times** — Set the on and the off times of the maximum misting timer.

**Start & stop at** — Specify the period of time over which the output can run.

## 7. HEATING

The controller can control up to 8 independent heating outputs. Each heating output operates according to its start and stop temperature. Refer to section 4.5 to enable heating outputs.



**Reference Temperature:** The start/stop temperatures of the heating outputs are related to the set point. This means that they are automatically adjusted when the set point changes.

**Heaters 1-4:** The controller has 4 basic heating outputs.

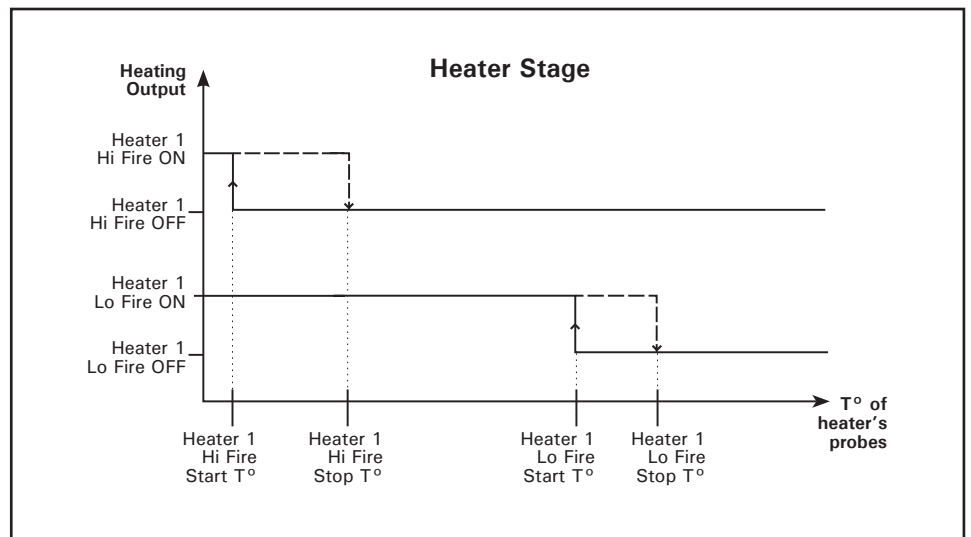
**Heaters' Hi Fire:** In addition to its 4 basic heating outputs, the controller can simulate additional heating outputs with the Hi Fire option. When this option is used, the controller doubles the number of heating outputs in use. Each simulated heating output (Hi Fire Step) operates as a regular heating output, with its own start/stop temperatures, relay selection and probe selection. Refer to section 4.5 to activate the heaters' Hi fire option.



1. Select:

-  Main menu
-  Start/Stop\*
-  Heaters

Heaters Start / Stop	
<b>Heater 2</b>	
Lo fire	On 71.0 °F
	Off 73.0 °F
Hi fire	On 70.0 °F
	Off 73.0 °F
<b>Heater 1</b>	
Lo fire	On 73.0 °F
	Off 75.0 °F
Hi fire	On 72.0 °F
	Off 75.0 °F

Use ▼ to navigate

\*A password may be required to access this menu.

2. Set the following parameters:

**On temperature** — Set the temperature below which each heating stage starts. If the Hi/Lo fire option is used, set this temperature separately for both steps of the heating stage.

**Off temperature** — Set the temperature at which each heating stage stops. Note that the "Off Temperature" of an heating stage must be at least 0.5°F (0.3°C) higher than its "On Temperature". If the Hi/Lo fire option is used, set this temperature separately for both steps of the heating stage.

## 8. LIGHTS





The controller has one 0-10V output that can be used to control the light intensity. Additional lights can also be connected to On/Off relays: these lights simply turn on when the 0-10V lights reach a user-defined intensity. Refer to section 4.5 to enable light programs and refer to section 4.8 to enable on/off light relays.

**Light Programs:** The controller can use 10 different light programs containing 6 daily light cycles each. The same program is performed every day until another program replaces it (the program selection is made according to the age of the animals).

**Light Cycles:** Up to 6 different light cycles can be performed in the course of a light program. These cycles are used to change the light intensity over the day (see graph below).

**Light Peaks:** A light peak is a marked increase in the light intensity. They are used to stimulate the animals. When light peaks are used, they are performed right after the sunrise, at the very beginning of the cycle. They are then performed on a regular basis, according to a user-defined timer.

1. Select:

-  Main menu
-  Start/Stop
-  Light\*
-  Select the desired light program

\* This menu is accessible if the light output is enabled in the Installation Setup (section 4.5).

Light Settings	
Day	7 days
Lights on 24 hours?	No
Minimum intensity	20 %
Sunrise	2 min
Sunset	2 min
Number of cycles	1
Cycle	Cycle 1
Start Time	12:00A
Stop Time	12:00A
Standard Intensity	80 %
Use light peaks?	Yes
Peak Cycle	0:15 (h:m)
Peak Duration	1 min
Peak Intensity	100 %
Peak Sunrise	2 min
Peak Sunset	2 min

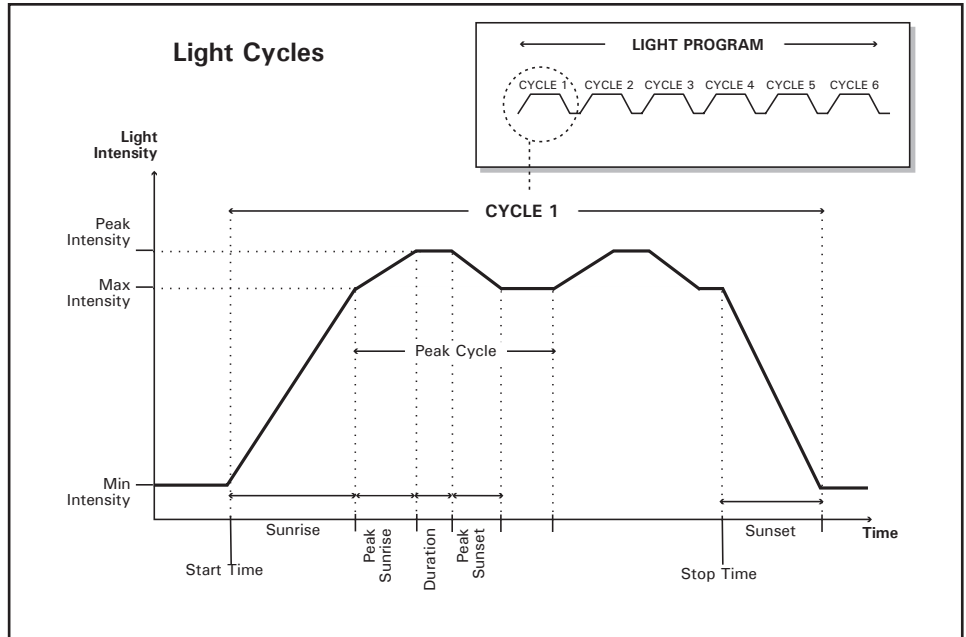

2. Set the following parameters:

**Day** — This is the day at which the selected program starts. It can be set from -5 to 450 days. Negative day values are used to prepare the house before letting the animals enter the building.

**Lights on 24 Hours** — Select "Yes" for lights to stay lit all day long; select "No" to use light cycles.

**Maximum Intensity** — If the "lights on 24 hours" option is enabled above, set the maximum light intensity to the desired value. \*This parameter is accessible if the "Lights on 24 hours" option is enabled above.

**Minimum Intensity** — Set the light intensity that is used when light cycles are off. Adjustable from 0% (Off) to 100%. \*This parameter is accessible if the "lights on 24 hours" option is disabled above.

**Sunrise** — When a cycle starts, the light intensity increases from its minimum to its maximum intensity over this delay (see previous graph). Set the sunrise delay to the desired value (from 1 to 60 minutes). \*This parameter is accessible if the "lights on 24 hours" option is disabled above.

**Sunset** — When the stop time of a light cycle is reached, the light intensity gradually decreases from its maximum to its minimum intensity over this delay (see previous graph). Set the sunset delay to the desired value (from 1 to 60 minutes). \*This parameter is accessible if the "lights on 24 hours" option is disabled above.

**Number of Cycles** — Select how many cycles must be performed during the selected light program. Adjustable from 1 to 6 cycles. \*This parameter is accessible if the "lights on 24 hours" option is disabled above.

**Cycle Selection** — Select the desired light cycle. The following parameters are related to this cycle: \*This parameter is accessible if the "lights on 24 hours" option is disabled above.

**Start Time** — Set the time at which the selected cycle starts. Make sure light cycles never overlap each other. \*This parameter is accessible if the "lights on 24 hours" option is disabled above.

**Stop Time** — Set the time at which the light intensity starts decreasing (sunset). \*This parameter is accessible if the "lights on 24 hours" option is disabled above.

**Standard Intensity** — Set the normal light intensity of the light cycle. This parameter ranges from the minimum light intensity to 100%. *\*This parameter is accessible if the “lights on 24 hours” option is disabled above.*

**Use Light Peaks?** — Select “Yes” to use light peaks or select “No” to disable them.

**Peak Cycle** — Select how much time is required to perform a light peak cycle (see previous graph). The “Cycle Time” must be even or longer than the peak duration + peak sunrise + peak sunset. *\*This parameter is accessible if light peaks are enabled above.*

**Peak Duration** — Select during how much time the light peak intensity must be maintained (from 1 to 59 minutes). *\*This parameter is accessible if light peaks are enabled above.*

**Peak Intensity** — Set the light peak intensity to the desired value. It ranges from the “Standard Intensity” parameter value to 100%.

*\*This parameter is accessible if light peaks are enabled above.*

**Peak Sunrise / Sunset** — Select the duration of the peak sunrise and sunset (see previous graph). These parameters range from 1 to 60 minutes. *\*This parameter is accessible if light peaks are enabled above.*

## Light Relay Settings

This section explains how to set the intensity of 0-10V light outputs at which light relays must turn on.

1. Select:

-  **Main menu**
-  **Start/Stop**
-  **Light\***

*\*This menu is accessible if light programs are used (sec. 4.5).*

Light Settings	
.....	Activate relay at: 0%
.....	
.....	

2. Set the following parameters:

**Activate relay at** — Set the intensity of the 0-10V output at which light relays must turn on.



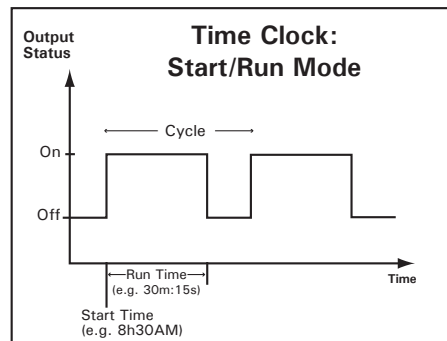
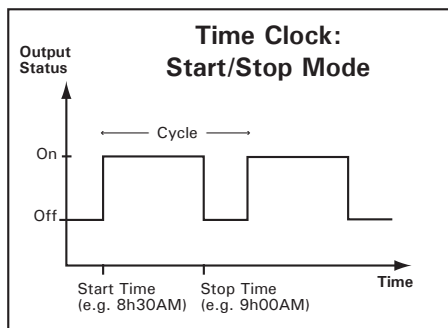

## 9. CLOCK OUTPUTS

The controller has 2 outputs to control various devices using the real-time clock. These clock output can use up to 12 timer cycles.

A clock output starts when the “On Time” of a timer is reached; it either stops after a certain run time or at a certain time of day. The following diagrams show both possibilities:



1. Select:

-  **Main menu**
-  **Start/Stop\***
-  **Clock\*\***
-  **Clock #x**

*\* A password may be required to access this menu.*

*\*\* This menu is accessible if at least 1 clock output is enabled in the Installation Setup (section 4.5).*

Clock #x	
.....	<b>Clock Mode Start/Stop</b>
.....	1. On Time 6:00A h:m
.....	Off Time 6:00A h:m
.....	[or]
.....	<b>Clock Mode Start/Run</b>
.....	1. On Time 6:00A h:m
.....	Run Time Hour 0
.....	Minutes 0
.....	Seconds 0
.....	Use ▼ to navigate

2. Set the following parameters:

**Clock mode** — The clock mode allows stopping a clock output at a certain time of the day or after a certain run time. Select “Start/Stop” to specify the time at which each cycle starts and stops or select “Start/Run” to specify the running time of each cycle. Note that the “Start/Run” option allows stopping cycles with more precision since this mode allows adjusting the seconds.

**On Time / Off Time or Run Time** — Set the time at which each cycle starts then set the moment at which each cycle ends.

## 10. RELATIVE HUMIDITY (RH) COMPENSATION

The controller offers different way to compensate for high/low relative humidity (RH) levels in the room. All compensation functions are explained below. To use them, you must enable each desired compensation function in section 4.6.

**1. High RH Comp. with the Heating Outputs:** The controller can compensate for high humidity levels by activating the heaters in timer mode. As the RH level increases, the controller increases the “On Time” portion of the heating timer to compensate for the change. The maximum compensated heating “On Time” is reached when the RH level is 10% above the RH Set Point.

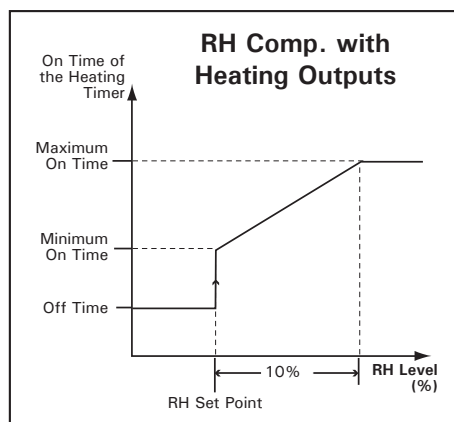

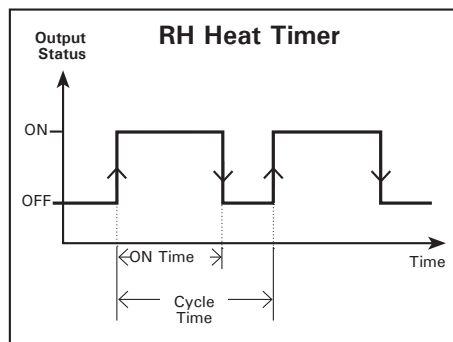

The RH heat timer is composed of an “On Time” and of a “Cycle Time”. The heaters run during the “On Time” and then stop until the end of the “Cycle Time”. The “On Time” portion of this cycle increases as the RH level increases.



**2. High RH comp. with cool cells & mist outputs:** If RH levels are too high, the controller can stop the misting output and/or cool cell output. These outputs are disabled when RH levels reach the respective *RH shutoff* limit of each output.

**3. Low RH comp. with mist outputs:** To compensate for low RH levels, the controller can activate the misting output in timer mode. The misting output starts when RH levels decrease below the *Low RH Set Point*.

1. Select:

-  Main menu
-  RH Comp\*

*\* This menu is accessible if at least one RH compensation function is enabled in section 4.6. In addition, a password may be required to access this menu (section 4.2).*

RH Compensation	
RH Set Point	65 %
<b>Heater Compensation</b>	
Min On Time	15 sec
Max On Time	45 sec
Cycle Time	300 sec
<b>Mist on Low % Humidity</b>	
Low Set Point	Off %
On time	15 sec
Off Time	900 sec
Mist Shutoff	Off %
Cool Cell shutoff	Off %
Use ▼ to navigate	

2. Set the following parameters:

**RH Set Point** — This is the humidity level above which high RH compensation functions start. Adjustable from 20 to 99% of humidity (select *Off* to disable all high RH comp functions).

### Heater compensation

The timer used by heating outputs is made of an “On Time” and of a “Cycle Time”. Heating outputs run during the “On Time” then stop until the end of the “Cycle Time”. The “On Time” portion of this cycle increases as RH levels increase.

**Minimum & Maximum On Times** — Set the minimum and maximum “On Times” of the heating timer. The minimum “On Time” starts being used when indoor humidity levels reach the RH set point; the maximum “On Time” is

used when humidity levels are 10% above the RH set point. *\* This parameter is accessible if RH compensation with heating outputs is enabled in section 4.6.*

**Cycle Time:** — Set the “Cycle Time” of the heating timer. *\* This parameter is accessible if RH compensation with heating outputs is enabled in section 4.6.*

### Misting outputs on low humidity levels

*\* Accessible if RH comp. on Low RH levels is enabled in section 4.6.*

**Low Set Point** — Set the humidity level below which misting units start running in timer mode or select “Off” to disable this function.

**On & Off Times** — Set the “On Time” and the “Off Time” of the misting timer.

**Mist & Cool Cell Shutoff** — Set the humidity level above which the misting output and/or the cool cell output stops or select *Off* to disable this function. *\* This parameter is accessible if the mist shutoff compensation and/or cool cell shutoff option is enabled in sec. 4.6.*

## 11. ALARMS



When an alarm occurs, the controller lights up the alarm pilot light, displays letters "AL" on the LED display, and post the alarm condition into the alarm log menu. The table on the right gives a list of all possible alarm conditions.

Another alarm situation occurs when power to the controller fails. In this case, the alarm relay is activated. When the alarm relay is activated, the normally open contact (—●—) closes.

Display	Meaning
Low Temperature Alarm	Low temperature alarm
High Temperature Alarm	High temperature alarm
Low Static Pressure	Low static pressure alarm
High Static Pressure	High static pressure alarm
Probe #1-8 Defect	A temperature probe is defective
Outside Probe #x Defect	Outside probe #x is defective
Whisker Switch Defect	The Whisker switch is defective
Water Spill	Water consumption too high
SP Sensor Defect	The static pressure sensor is defective
Inside RH Sensor Defect	The indoor humidity probe is defective
Outside RH Sensor Defect	The outdoor humidity probe is defective
Relay panel comm. Error	Communication is disrupted between controller and relay panel.
Inlet potentiometer defect	The potentiometer is defective.
Feeder #x run time exceeded	A feeder has been running continuously on a too long period of time.
Water module comm. Error	Communication is disrupted between controller and water meter module.

### 11.1. Alarm Log

1. Select:

-  Main menu
-  Monitoring
-  Alarm Log

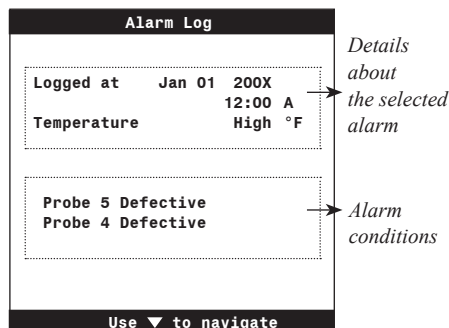

### 11.2. Alarm Conditions

#### Temperature Alarms

The diagram below shows how temperature alarms are detected.

When the average room temperature exceeds the high temperature alarm setting, a high temperature alarm is set off. When the average room temperature decreases below the low temperature alarm setting, a low temperature alarm is set off. Although these settings are entered by the user as absolute values, they are defined based on the room set point. They are thus automatically adjusted if the set point changes.

The situation is slightly different when the outside temperature is greater than the room set point. In this case, the outside temperature becomes the reference point (instead of using the set point as a the reference). This means an alarm is set off when the room temperature reaches *Outside Temperature + High Alarm Offset* (the offset being the difference between the high alarm temperature setting and the set point). A third parameter, called

the *Critical Temperature*, is defined to continue monitoring the indoor temperature for high temperatures. When the indoor temperature reaches the critical high temperature (defined as an absolute value), an alarm is set off.

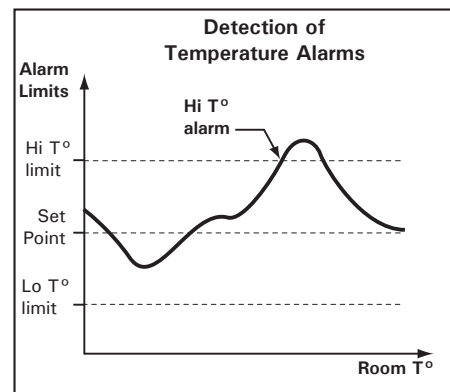

#### Temperature Alarms in Clean Mode

The controller can monitor low temperature alarms when it is in clean mode. If this alarm condition is used, the controller sounds an alarm when the temperature falls below low alarm limit that is associated to the clean mode.

The low alarm limit used in clean mode is related to the clean mode set point; this means the alarm limit is automatically adjusted when the clean mode set point changes.

#### Water Spill Alarm

A water spill alarm sets off when the consumption of a water meter exceeds its consumption limit. This limit can range from 1 to 10,000 gallons or liters per 15 minutes.

#### Static Pressure Alarms



The controller can sound an alarm when the static pressure (SP) level exceeds high or low pressure limits for a certain period of time.

#### Feeder Alarm

The controller sets off an alarm if a feeder runs continuously on a too long period of time. When this type of alarm occurs, the relay associated with the problematic feeder opens in order to stop the feeder motor. This alarm condition is optional.

## 11.3. Alarm Settings

1. Select:

-  Main menu
-  Start/Stop\*
-  Alarms

\* A password may be required to access this menu.

Alarm Settings	
<b>Temperature Alarms</b>	
Clean Mode	32.0 °F
Low Alarm	60.0 °F
High Alarm	90.0 °F
Critical Alarm	100.0 °F
<b>Water Spill Limit</b>	
Water 1 Spill Limit	100 Lit
Water 2 Spill Limit	100 Lit
<b>Static Pressure Alarm</b>	
Low Alarm	.010 "WC
High Alarm	.100 "WC
Delay	300 sec
<b>Feed Monitoring?</b>	
Feeder 1 Max Time	5 min
Feeder 2 Max Time	None min
<b>Activate the alarm relay with</b>	
Lo Temperature	Yes
Hi Temperature	Yes
Defective sensor	Yes
Pot. Defective	Yes
Whisker switch	Yes
Use ▼ to navigate	

2. Set the following parameters:

(Refer to the previous section to get further information on these parameters)

### Temperature Alarms

**Clean mode** — Set the temperature below which a temperature alarm is set off in clean mode.

**Lo/Hi alarm** — Set the room temperature below and above which a temperature alarm is set off.

**Critical temperature** — Set the absolute temperature above which an alarm is set off.

\*This parameter is accessible if an outside temperature probe is enabled (section 4.7.1).

**Water spill limit** — Specify the maximum amount of water that can be consumed by each water meter per 15 minutes (1-10,000 gal or liters/15 min). \*This parameter is accessible if a water meter is enabled (sec. 4.7.1)

### Static pressure limit

\*Accessible if a SP probe is enabled (section 4.7.1).

**Low / High alarm** — Set the pressure levels below and above which an alarm is set off.

**Delay** — The high or low pressure condition must be maintained on this period of time before the controller sets off the alarm. Set the static pressure alarm delay to the desired value (in seconds).

**Feeder monitoring** — Select "Yes" if you want the controller to monitor the run time of feeding inputs. If this alarm condition is enabled, set the maximum run time of each feeder (in minutes). Refer to section 4.8 to assign the relay that must open in case of a run time alarm. \*This parameter is accessible if feeders are enabled (section 4.5).

**Activate the alarm relay** — Select "Yes" if you want the controller to activate the alarm relay when the following alarm conditions occur:

- Lo / Hi Temperature
- Lo / Hi Static pressure
- Water spill
- Defective sensors: temperature, humidity, static pressure)
- Comm. error with the RP-16/RP-32/WME-8
- Defective potentiometer
- Defective Whisker switch

[Alarm conditions that activate the alarm relay are common to all programs].

## 12. MONITORING FUNCTIONS

### 12.1. Current Conditions

The current condition menu gives a quick overview of the actual conditions in the barn.

1. Select:

 Main menu

2. The current conditions (inputs and output) are shown on screen. Use the arrow keys to scroll the display.



Set Points	Installation	
Min. Vent.	Ambient Temperature	72.3 °F
	Current Stage	2
Vent/Inlet	Current Probe	Set 1
	Set Point	70.0 °F
History	Inside Humidity	Low %
	Outside Humidity	Low %
Age/Mortal	Static Pressure	.000 "WC
	Outside T°	High °F
Clean Mode	Heating Stages	xx
	Clock Output	xx
Start/Stop	Vent/Inlet 1 Position	0 %
	Vent/Inlet 2 Position	0 %
Monitoring	Running Prog:	Program 1
	Temperature Probe 1	72.3 °F
Program	Temperature Probe 2	72.4 °F
Selection	Temperature Probe 3	72.3 °F
	Temperature Probe 4	72.1 °F
Setup	Yesterday Water 1	0 Gal
	Yesterday Water 2	0 Gal
Time/Date	Yesterday Water 3	0 Gal

Use ▼ to navigate

### 12.2. Run Time Histories

Monitoring menus contain the daily run time of the following outputs: water meter, feeders & heaters. The controller keeps these daily run times in memory for 75 days and logs these values into monitoring menus at midnight.

1. Select:

-  Main menu
-  Monitoring
-  Select the desired monitoring menu:
  - Feeders
  - Heaters





Heater Run Time 75 days	
Total	0 min
Today	0 min
Jan 02 200X	0 min
Jan 01 200X	0 min

Use ▼ to navigate

#### Resetting the run time of a feeder

To reset the run time of a feeder, select the following menus then follow the prompts on screen.



1. Select:

-  Main menu
-  Monitoring
-  Feeders
-  Reset Run Time

### 12.3. History Menus

History menus give a daily record of probe readings and of the animal count. These pieces of information are logged into history menus at midnight. Refer to section 12.2 to consult run time histories (for heaters, water consumption and feeders).

1. Select:

-  Main menu
-  History
-  Select the desired type of history:

**Ambient temperature** — This menu contains the daily minimum and maximum readings of the room temperature of the past 60 days.

**Probe temperature** — This menu contains the daily minimum and maximum temperature readings of each temperature probe for the past 10 days.

**Outside temperature** — This menu contains the daily minimum and maximum readings of outside temperature probes for the past 75 days. *\*This parameter is accessible if an outside temperature sensor is enabled (section 4.7.1).*

**Inside relative humidity (RH)** — This menu contains the daily minimum and maximum inside humidity readings of the past 75 days. *\*This parameter is accessible if the inside humidity sensors is enabled (sec. 4.7.1).*

**Outside relative humidity (RH)** — This menu contains the daily minimum and maximum outside humidity readings of the past 75 days. *\*This parameter is accessible if the outside humidity sensors is enabled (sec. 4.7.1).*

**Static Pressure** — This menu contains the daily minimum and maximum static pressure readings of the past 75 days. *\*This parameter is accessible if a static pressure sensor is enabled (sec. 4.7.1).*

**Mortality / Culled / Marketed** — These menus contain the daily count of mortalities, culled, and of marketed animals of the past 75 days. *\*This parameter is accessible if age-based functions are enabled (section 4.5).*

**Water Consumption** — This menu contains the daily water consumption measured by each water meter for the past 75 days. *\*This parameter is accessible if at least one water meter is enabled in section 4.7.1.*



## 12.4. Animal Age & Count

**Animal age:** Some parameters of the controller can automatically change over time as the animals grow up (curves, programs & tunnel door). Using age-based parameters is optional, refer to section 4.5 to enable or disable the animal age function.

**Animal count (Current count / mortality / culled / marketed):** At the beginning of a group, the user must specify the initial number of animals. Afterwards, the user can specify the number of mortalities, culled, and marketed animals as it occurs.

 **ALL histories of the controller are reset when a new group starts.**

1. Select:

-  Main menu
-  Age/Mortality\*

Age & Mortality	
Animal Age	-4 day
Initial Count	1200
Current Count	1200
Start New Group?	No
New Mortality	0
Today's Mortality	0
Tot. Mortality	0
New Culled	0
Today's Culled	0
Total Culled	0
New Marketed	0
Today's Marketed	0
Total Marketed	0

\*This menu is accessible if age-based functions are enabled in the Installation Setup (section 4.5)

2. Set the following parameters:

**Animal age** — The animal age can be adjusted from -5 days to 450 days. Negative day values are used to prepare the house before letting the animals in.

**Initial count** — Enter the initial number of animals in the room before enabling the new group.

**Current count** — The current count is automatically adjusted as mortalities, culled animals or marketed animals are posted.

**Starting a new group** — Before starting a new group, enter the animal age and the initial count.

 **ALL histories of the controller are reset when a new group starts.**

**New mortalities** — Enter the number of new mortalities. Once a number is entered, the parameter value automatically goes back to "0" and the value is added to the total number of mortalities and removed from the current count.

**New culled** — Enter the number of culled animals. Once a number is entered, the parameter value automatically goes back to "0" and the value is added to the total number of culled animals and removed from the current count.

**New marketed** — Enter the number of marketed animals. Once a number is entered, the parameter value automatically returns to "0" and the value is added to the total number of marketed animal and removed from the current count.

## 12.5. Automatic Reminder

The controller can display warning messages at regular intervals. The automatic reminder allows you to associate a warning message to a servicing activity for instance then decide the frequency at which this servicing activity must be performed. In all, the controller can display 3 different warning messages.

When a warning message is active, the word "Warning" is displayed on screen, along with the message number.

1. Select:

-  Main menu
-  Setup\*
-  User
-  Warning

Warning	
Show Warning1 every	10 days
Show Warning2 every	100 days
Show Warning3 every	Off days
Clear Warning 1?	Yes

\*A password may be required to access this menu.

2. Set the following parameters:

**Show warning 1-3 every** — Select the frequency at which each warning message is displayed (1 to 450 days); select *Off* to disable a warning message.

**Clear Warning #x ?** — This menu appears when the timer of a warning message has elapsed. Select "Yes" to reset the timer of a warning message.

 **Please write down the meaning and the frequency of warning messages 1-3:**

#	MEANING	FREQUENCY
Warning 1		every ___ days
Warning 2		every ___ days
Warning 3		every ___ days

## 13. TECHNICAL SPECIFICATIONS

Type.....	EXPERT WW
Main supply fuse F1.....	 4A, slow-blow
Mains supply/frequency .....	90-240VAC, 50/60Hz, 30W max
0-10V outputs.....	0-10Vdc, 30mA source max.
Precision on 0-10V outputs .....	±1 %
14Vdc output .....	14 Vdc ±10%, regulated, 250 mA max.
Alarm contact .....	150 mA, 24 Vac or dc max.
Pot + output .....	3.0V, 20 mA max.
RH input .....	4-20 mA
Outside RH input .....	0-2.5Vdc
Temperature inputs.....	1K @ 77 °F (25 °C), NTC
Relays 1-20.....	Dry contact 15 A RES, 50/60 Hz 16 FLA @ 120 VAC (1HP, 746 W) 12 FLA @ 240 VAC (2HP, 1490 W) Max tungsten(light bulb): 8.3A @ 120Vac
Housing.....	IP54, plastic casing
Operating temperature .....	32 to 104°F (0 to 40 °C)
Storage temperature .....	5 to 122 °F (-15 to 50 °C)
Ambient relative humidity.....	max. 95%
Pollution degree.....	2
Altitude .....	Up to 2000m

 ***The relay strips of the RP-16, RP-32 and of the Expert WW control are not compatible and cannot be interchanged from one device to the other.***

## 14. MEMORY CARD

### 14.1. Principle of Operation

The memory card allows you to upgrade the firmware or software of your controller without losing your parameter settings (firmware and/or software upgrade). The card can also be used to make a backup of your controller settings or to copy these settings on another controller of the same type.

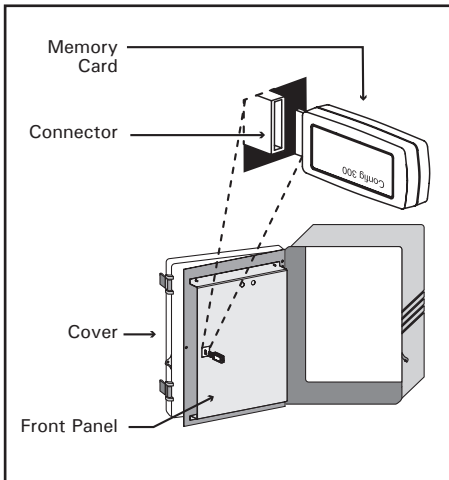

Various kind of files can be stored on the card: configuration files (\*.cfg files) and/or firmware files (\*.fir and \*.bin files). Refer to section 14.3 to load or save a configuration file; refer to section 14.4 to upgrade the firmware.

### 14.2. Accessing the Transfer Menu

1. Unscrew the screws located on the controller's front panel then open the panel.
2. Insert the memory card in the connector located on the electronic board located on the back of the front panel (see illustration).
3. Close the front panel then simultaneously press the up- and down-arrow keys for 3 seconds to display the transfer menu.
4. Select the desired transfer menu:

- Main menu
- Memory Card → Controller
- or
- Controller → Memory Card

### 14.3. Configuration Transfer Configuration Files (\*.cfg)

Configuration files are a set of instructions that tells the controller what to do. These files are divided into three parts:

- 1) Software (screen menus)
- 2) User data (parameter settings)
- 3) Potentiometer calibration

You can save your controller's configuration on the card or you can install a new configuration into your controller. Note that it is now possible to install a specific component of the configuration without affecting the two other components. For instance, you can upload new controller software without affecting your calibration & parameter settings.

#### 14.3.1. Installing a New Configuration

The following procedure shows how to install a new configuration in your controller. You can choose to install the whole new configuration or to install a specific component of it.

1. Access the transfer menu as explained in section 14.2 and select the "Memory card to controller" menu.

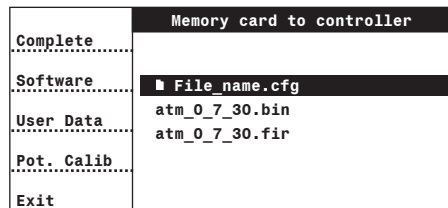

2. Select the proper configuration file (\*.cfg) on the main screen. The icon indicates which files can be used for the transfer.

3. Press the button that corresponds to the component(s) you want to install:

- Complete (all components)
- Software (screen menus)
- User data (parameter settings)
- Pot. Calib (inlet calib. settings)

4. Once the transfer is over, press Exit then remove the memory card from the connector.

#### 14.3.2. Saving a Configuration on the Card

The following procedure shows how to save your controller's configuration into the memory card. This will create a configuration file (\*.cfg) on the card.

1. Access the transfer menu as explained in section 14.2 and select the "Controller to Memory card" menu.

2. The name of the configuration file (\*.cfg) is shown at the top of the screen and the table at the bottom gives information about the memory card. Press "Complete" to save your controller's configuration on the card.

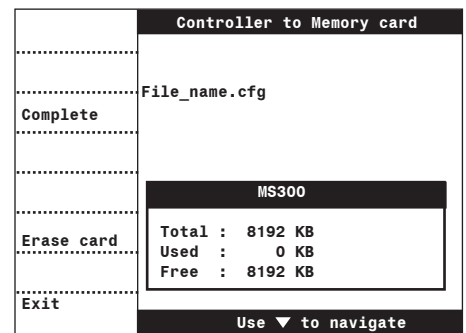

3. Once the transfer is over, press Exit then remove the memory card from the connector.

## 14.4. Firmware Update

### Firmware Files (\*.fir)

The controller's firmware contains instructions and data responsible for controlling the controller. When a new firmware version is available, you can install it in your controller by downloading a firmware file (\*.fir) from the card. Upgrading the firmware will not affect your parameter settings.

1. Access the transfer menu as explained in section 14.2 and select the "Memory card to controller" menu.

2. Press and hold the up- and down-arrow keys simultaneously for 3 seconds. The Firmware Update menu is displayed.

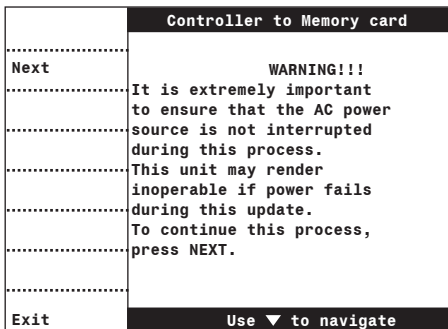

3. Read the warning message carefully then press Next.

4. Select the proper firmware file (\*. fir) on the main screen. The  icon indicates which files can be used for the transfer.

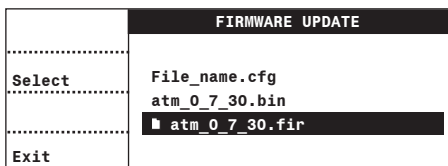

5. Press "Select" to get information about the selected firmware file (\*.fir).

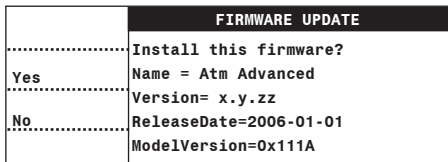

6. Press "Yes" to install the selected firmware or select "No" to go back to the previous menu.

7. Once the transfer is over, press Exit then remove the memory card from the connector.

## 14.5. Erasing the Memory Card

Follow this procedure to delete all the content of the memory card.

1. Access the transfer menu as explained in section 14.2 and select the "Controller to Memory card" menu.

2. Press "Erase card" to delete all files that are stored on the card.

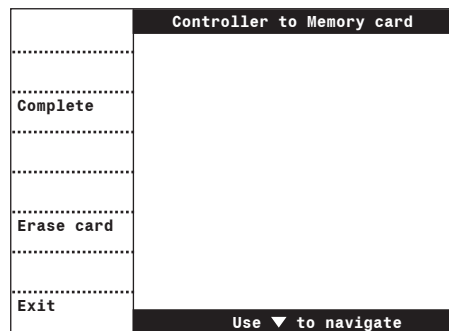

3. Once the card is erased, press Exit then remove the memory card from the connector.

## 15. INDEX

### A

Age. *See Animals*

#### Alarms

- Alarm conditions 38
- Alarm log 38
  - Reset the alarm log 12
- Alarm relay 39
- Alarm settings 39

#### Animals

- Animal count
  - History 40
  - Posting changes to the animal count 41
- Enabling animal age functions 12
- Starting a new group 41

### B

#### Backup

- Backup relay
  - Activation 12
  - Relay assignment 14
- Making a backup of the controller 43

#### Buttons 7

### C

#### Calibration

- Probe calibration 13
- Vent door (inlet) calibration
  - see Vent door/inlet (potentiometer)
- Water meter calibration 13

#### Celsius units 10

#### Clean mode

- Alarms 38, 39
- Clean mode set point 17
- Operation & settings 15

#### Clock

- Display : AM/PM or 24hours 10
- Setting the time and date 9

#### Clock outputs

- Activation 11
- Current status 40
- Operation & settings 36
- Relay assignment 14

#### Compensation

- Relative humidity comp.. *See Relative humidity comp.*

#### Connections 6, 7

#### Contrast (LCD screen) 7

#### Controller

- Features 5
- Firmware update 44
- Installation setup 11–12
- Location of the controls 7
- Mounting instructions 6

#### Software

- Language selection 8
- Version 16
- Technical specifications 42

#### Cool cells

- Activation 12
- Operation & Settings 33
- Relay assignment 14
- RH comp. on the cool cell output
  - Activation 13
  - Principle of operation 37
  - Settings 37

#### Copy & Paste function 10

#### Culled

- History 40
- Posting # of culled animals 41

#### Current conditions 40

#### Curtains. *See Natural ventilation curtains*

#### Curves

- Minimum ventilation - On Time curve
  - Principle of operation 19
  - Settings 19
- Set point curve
  - Curve offset 18
  - Enable the curve function 12
  - Principle of operation 18
  - Settings 18

### D

#### Date 9

#### Day / Night

- Activation 15
- Day/night times 15
- Night set point
  - Principle of operation 17
  - Settings 17

#### Display

- Red LED display
  - Location 7
  - Unit selection 12

### E

#### Electrical specifications 42

#### English software 8

#### Evaporative pads. *See Cool cells*

### F

#### Fahrenheit units 10

#### Fan stages

- Activation 11
- Current fan stage in use 40
- Minimum ventilation. *See Minimum ventilation*
- Principle of operation 20
- Relay assignment 14
- Settings 20
- Timer relays
  - Principle of operation 20
  - Timer settings 20

#### Fan stages (0-10V fans)

- Activating 0-10 V outputs 11
- Operation & settings 21
- Probe assignment 14

#### Feeders

- Activation 11
- Relay assignment 14
- Run time alarm
  - Principle of operation 38
  - Settings 39
- Run time history 40

#### Fire. *See Heaters*

#### Firmware update

- Principle of operation 44
- Settings 44

### G

#### Gallons 10

### H

#### Heaters

- Activation 11
- Current status 40
- Lo/Hi fire
  - Activation 11
- Operation & Settings 34
- Probe assignment 14
- Relay assignment 14
- RH compensation on heaters
  - Activation 13
  - Principle of operation 37
  - Settings 37
- Run time history 40

#### Hi/Lo Fire. *See Heaters*

#### History menus 40

#### Humidity. *See Relative humidity*

### I

#### Index 45

#### Inlets

- Potentiometer-based inlets. *See Vent door/inlet*
- Pressure-based inlets. *See Vent door/inlet (pressure-based)*
- Timer-based inlets. *See Vent door/inlet (timer-based)*

#### Inlets (0-10V inlet output)

- Activation 11
- Principle of operation 32
- Probe assignment 14
- Settings 32

#### Inputs

- Activation 13
- List of available inputs 5

#### Installation setup 11–12

#### Installer password. *See Password*

### L

#### Language selection 8

- LCD screen
  - Backlight button 7
  - Contrast adjustment 7
  - Location 7
- LEDs
  - LED display
    - Location 7
    - Unit selection 12
  - LED meaning 8
- Lights
  - Activation 11
  - Operation & Settings 35–36
  - Relay assignment 14
- Liters 10
- M**
- Main menu button 7
- Marketed animals
  - History 40
  - Posting # of marketed animals 41
- Measuring units 10
- Memory card
  - Erasing the card 44
  - Transfer process 43
- Menu selectors 7
- Minimum ventilation
  - Activation 19
  - Principle of operation 19
  - Relay assignment 15
  - Settings 19
  - Stage 1 ramping. *See Ramping*
- Minimum ventilation curves
  - Principle of operation 19
  - Settings 19
- Misting output
  - Activation 12
  - Operation & settings 33
  - Relay assignment 14
  - RH compensation on the mist output
    - Activation 13
    - Principle of operation 37
    - Settings 37
- Mortality
  - Entering new mortalities 41
  - History 40
  - Posting # of mortalities 41
- Mounting instructions 6
- N**
- Natural ventilation curtain
  - Outside T° compensation 24
  - Outside T° set point 17
  - Principle of operation 22
  - Probe assignment 14
  - Purge cycles 25
  - Settings 23
  - Shutoff fans
    - Principle of operation 24
  - Relay selection 14
  - Tunnel & Natural vent. transition 23
- Night. *See Day/night*
- O**
- Outputs
  - Activation 11
  - List of available outputs 5
  - Relay assignment
    - Making the assignment 14
- Outside RH. *See Relative humidity*
- Outside T°. *See Temperature*
- P**
- Parameter adjustment 8
- Password
  - Default user level 12
  - Enable/disable the password 12
  - Entering/changing the password 9
  - Retrieving a lost password 9
- Probe
  - Activation 13
  - Assignment 14
  - Calibration 13
  - Connection 7
  - Extension 7
  - Probe sets
    - Current probe set in use 40
    - Principle of operation 26
    - Probe assignment 14
    - Settings 27
- Programs
  - Automatic program switch
    - Activation 12
    - Settings 9, 12
  - Copy/paste program settings 10
  - Current program in use 40
  - Enabling programs 12
  - Principle of operation 9
  - Program selection 9
- Purge cycles
  - Activation 12
  - Operation & settings 25
- R**
- Ramping (stage 1)
  - Activation 12
  - Principle of operation 20
- Relative humidity (RH)
  - Inside RH sensor
    - Activation 13
    - Calibration 13
    - Current reading 40
    - History 40
  - Outside RH sensor
    - Activation 13
    - Calibration 13
    - Current reading 40
    - History 40
- RH Compensation
  - Activation 13
  - Principle of operation 37
  - Settings 37
  - RH set point 37
- Relay panel 12
- Relays
  - Alarm relay 39
  - Relay assignment
    - Making the assignment 14
  - Shutoff fan relays in natural ventilation
    - Principle of operation 24
    - Relay selection 14
  - Timer relays
    - Principle of operation 20
    - Timer settings 20
- S**
- Screens (LED & LCD) 7
- Sensors. *See Probes*
- Set points
  - RH set point. *See Relative humidity*
  - Static pressure set points. *See Static pressure*
  - Temperature set points 17
- Setup (Installation) 11–12
- Simulation (temperature) 16
- Spanish software 8
- Static pressure (SP)
  - Current pressure level 40
  - Measuring units 10
  - Pressure alarms
    - Principle of operation 38
    - Settings 39
  - Probe history 40
  - SP Probe
    - Activation 13
    - Calibration 13
  - Static pressure set points
    - Activating pressure groups 11
    - Operation & settings 17
- T**
- Technical specifications 42
- Temperature
  - Average room temperature
    - Current average T° 40
    - History 40
    - Probe assignment 14
    - Probe set 2 - probe assignment 14
    - Probe set in use 40
  - Inside temperature probes
    - Activation 13
    - Current probe readings 40
    - History 40
    - Probe assignment 14
    - Probe calibration 13
  - Outside temperature
    - Activation 13
    - Current probe reading 40

- History 40
  - Outside T° set point 17
  - Probe calibration 13
  - Temperature alarms
    - Principle of operation 38
    - Settings 39
  - Temperature set points
    - Clean mode set point 17
    - Current set point 40
    - Night set point 17
    - Operation & settings 17
    - Outside T° set point 17
    - Temperature curve 18
  - Temperature simulation 16
  - Temperature units 10
  - Test mode 16
  - Time
    - Setting the time and date 9
    - Time format 10
  - Tunnel doors (pressure-based)
    - Activation 11
    - Principle of operation 25, 25–27
    - Probe set 2 27
    - Settings 27
    - Static pressure limits 17
    - Tunnel doors following natural curtains 11
    - Tunnel & Natural vent. transition 23
  - Tunnel doors (temperature-based)
    - Activation 11
    - Principle of operation 25, 26–27
    - Probe set 2 27
    - Settings 27
    - Tunnel doors following natural curtains 11
    - Tunnel & Natural vent. transition 23
- ## U
- Units 10
  - User password. *See Password*
- ## V
- Vent door/inlet (potentiometer)
    - Activation 11
    - Calibration
      - Loading an existing calibration 43
    - Operation & settings 31
    - Current position 40
    - Relay assignment 14
    - Settings 30
  - Vent door/inlet (pressure-based)
    - Activation 11
    - Current position 40
    - Principle of operation 31
    - Relay assignment 14
    - Settings 32
    - Static pressure limits 17
  - Vent door/inlet (timer-based)
    - Activation 11
    - Current position 40
    - Principle of operation 28–29
  - Relay assignment 14
  - Resetting the position 29
  - Settings 28
  - Ventilation
    - Fans. *See Fan stages*
    - Min. ventilation. *See Minimum ventilation*
  - Version (software) 16
- ## W
- Warning messages 41
  - Water meter
    - Activation 13
    - Calibration 13
    - Consumption history 40
    - Measuring units 10
    - Water spill alarm 38, 39
  - Whisker switch 12, 24
  - Wiring 6